

INTERNATIONAL STUDENT EDITION

THE HEINLE PICTURE DICTIONARY



Dictionaries from Heinle!

The Essential Tools for English Language Learners!

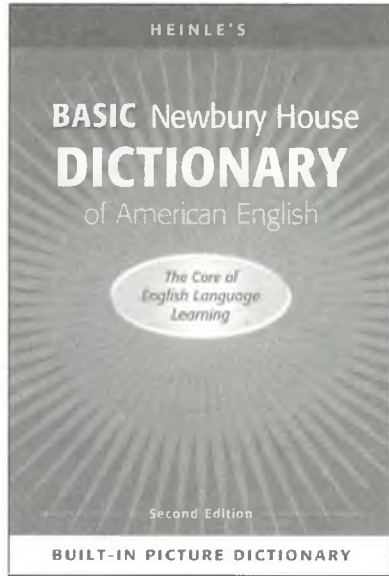

***Learner's Dictionary
Picture Dictionary
Activity Guide***

Softcover: 0-8384-2656-5
Hardcover: 0-7593-9808-9

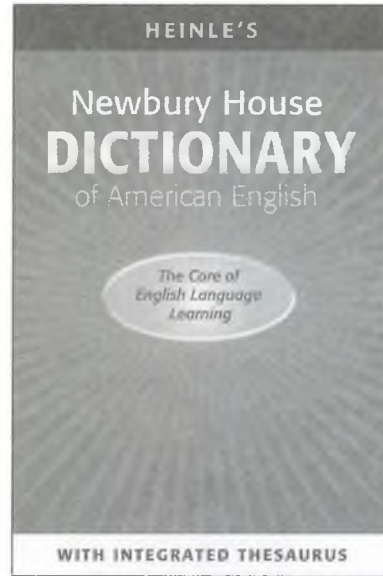

***Learner's Dictionary • Thesaurus
Brief Writer's Handbook
Activity Guide • Pronouncing CD-ROM***

Softcover with CD-ROM: 0-8384-2657-3
Hardcover: 0-8837-7017-2

To order your copy of Heinle's Newbury House Dictionary, the *All-In-One Essential Dictionary for English Language Learners*, call 1-800-354-9706 (In the U.S.), visit us at elit.thomson.com, or contact your local Heinle or Thomson Learning representative.

INTERNATIONAL STUDENT EDITION

THE HEINLE
PICTURE
DICTIONARY

THOMSON

HEINLE

Australia ♦ Canada ♦ Mexico ♦ Singapore ♦ United Kingdom ♦ United States



INTERNATIONAL STUDENT EDITION
The Heinle Picture Dictionary

Publisher, Adult & Academic: *James W. Brown*
Senior Acquisitions Editor, Adult & Academic: *Sherrise Roehr*
Director of Product Development: *Anita Raducanu*
Publisher, Global ELT: *Christopher Wenger*
Senior Development Editor: *Jill Korey O'Sullivan*
Developmental Editor: *Rebecca Klevberg*
Editorial Assistants: *Katherine Reilly, John Hicks, and Christine Galvin*
Director of Marketing: *Amy Mabley*
Senior Marketing Manager, Adult ESL: *Donna Lee Kennedy*
International Marketing Manager: *Eric Bredenberg*

Production Manager: *Sally Cogliano*
Senior Production Editor: *Maryellen E. Killeen*
Senior Print Buyer: *Mary Beth Hennebury*
Photo Researcher: *Melissa Goodrum*
Photo Editor and Permissions Manager: *Sheri Blaney*
Indexer: *Alexandra Nicherson*
Project Management, Design, and Composition:
Proof Positive/Farrowlyne Associates, Inc.
Cover Design: *Proof Positive/Farrowlyne Associates, Inc.*
Cover Image: © 2004 Roy Wiemann c/o the ispot.com
Printer: *Courier*

Copyright © 2005 by Thomson Heinle. Thomson Heinle and the Thomson logo are trademarks used herein under license.

All rights reserved. No part of this work covered by the copyright hereon may be reproduced or used in any form or by any means—graphic, electronic, or mechanical, including photocopying, recording, taping, Web distribution or information storage and retrieval systems—without the written permission of the publisher.

Printed in the United States of America.

4 5 6 — 07

For more information contact Thomson Heinle, 25 Thomson Place, Boston, MA 02210 USA, or you can visit our Internet site at <http://elt.thomson.com>

Credits appear on page 262, which constitutes a continuation of the copyright page.

For permission to use material from this text or product, submit a request online at <http://www.thomsonrights.com>

Any additional questions about permissions can be submitted by email to thomsonrights@thomson.com

Student Edition ISBN-13: 978-0-8384-4400-9

Student Edition ISBN-10: 0-8384-4400-8

International Student Edition ISBN-13: 978-1-4130-0444-1

International Student Edition ISBN-10: 1-4130-0444-X (Not for sale in the United States.)

Contents



1 Basic Words

Numbers	2
Time	4
Calendar	6
Money and Shopping	8
Colors	10
In, On, Under	12
Opposites	14
The Telephone	16



2 School

Classroom	18
Listen, Read, Write	20
School	22
Computers	24



3 Family

Family	26
Raising a Child	28
Life Events	30



4 People

Face and Hair	32
Daily Activities	34
Walk, Jump, Run	36
Feelings	38
Wave, Greet, Smile	40
Documents	42
Nationalities	44



5 Community

Places Around Town	46
Shops and Stores	48
Bank	50
Post Office	52
Library	54
Daycare Center	56
City Square	58
Crime and Justice	60



6 Housing

Types of Homes	62
Finding a Place to Live	64
Apartment Building	66
House and Garden	68
Kitchen and Dining Area	70
Living Room	72
Bedroom and Bathroom	74
Household Problems	76
Household Chores	78
Cleaning Supplies	80



7 Food

Fruits and Nuts	82
Vegetables	84
Meat, Poultry, and Seafood	86
Inside the Refrigerator	88
Food to Go	90
Cooking	92
Cooking Equipment	94
Measurements and Containers	96
Supermarket	98
Restaurant	100
Order, Eat, Pay	102



8 Clothing

Clothes	104
Sleepwear, Underwear, and Swimwear	106
Shoes and Accessories	108
Describing Clothes	110
Fabrics and Patterns	112
Buying, Wearing, and Caring for Clothes	114
Sewing and Laundry	116



9 Transportation

Vehicles and Traffic Signs	118
Parts of a Car	120
Road Trip	122
Airport	124
Taking a Flight	126
Public Transportation	128
Up, Over, Around	130



10 Health

The Human Body	132
Illnesses, Injuries, Symptoms, and Disabilities	134
Hurting and Healing	136
Hospital	138
Medical Center	140
Pharmacy	142
Soap, Comb, and Floss	144



11 Work

Jobs 1	146
Jobs 2	148
Working	150
Farm	152
Office	154
Factory	156
Hotel	158
Tools and Supplies 1	160
Tools and Supplies 2	162
Drill, Sand, Paint	164



12 Earth and Space

Weather	166
The Earth's Surface	168
Energy, Pollution, and Natural Disasters	170
The United States and Canada	172
The World	174
The Universe	176



13 Animals, Plants, and Habitats

Garden	178
Desert	180
Rain Forest	182
Grasslands	184
Polar Lands	186
Sea	188
Woodlands	190



14 School Subjects

Math	192
Science	194
Writing	196
Explore, Rule, Invent	198
U.S. Government and Citizenship	200



15 The Arts

Fine Arts	202
Performing Arts	204
Instruments	206
Film, TV, and Music	208



16 Recreation

Beach	210
Camping	212
City Park	214
Places to Visit	216
Indoor Sports and Fitness	218
Outdoor Sports and Fitness	220
Winter Sports	222
Games, Toys, and Hobbies	224
Camera, Stereo, and DVD	226
Holidays and Celebrations	228

Index	230
-------	-----

To the Teacher

About The Heinle Picture Dictionary

The Heinle Picture Dictionary is an invaluable vocabulary resource for students learning the English language. It presents the most essential vocabulary for beginning to intermediate students in a unique format. In contrast to conventional picture dictionaries that illustrate target words in isolation, *The Heinle Picture Dictionary* conveys word meaning through the illustration of these words within meaningful, real-world contexts. It also offers students a multitude of opportunities to see, use, hear, and practice these words in context.

The dictionary is organized into 16 thematic units. Each two-page lesson within a unit focuses on a sub-theme of the broader unit theme. So, for example, under the unit theme of *Housing*, there are lessons focusing on different styles of houses, specific rooms of a house, finding a house, household problems, household chores, etc.

The focal point of each lesson is the word list and the corresponding illustration(s) and/or photograph(s) that illustrate the words. The word lists are arranged for ease of navigation, with the words appearing in the order in which they are illustrated in the art. Singular words in the word list are preceded by an indefinite article (or the definite article, in special cases where the definite article would be more common or appropriate). The inclusion of articles is intended to help students understand when and how articles should be used with the words in the dictionary.

Each lesson includes *Words in Context*, *Words in Action*, and *Word Partnerships*. *Words in Context* is a short reading that features a selection of the words from the word list. *Words in Action* is a pair of activities that help students put the words into meaningful use. *Word Partnerships* is a selection of collocations that exposes students to high-frequency English word pairings using words from the word list.

Scientific Research Based

The Heinle Picture Dictionary was developed with research in mind. Research supports the idea that vocabulary is most effectively learned through repeated and varied exposure (Anderson, 1999) and through a strategic approach (Taylor, Graves, van den Broek, 2000). *The Heinle Picture Dictionary* provides students with not only clear illustrations to illuminate word meaning, but also numerous opportunities to encounter and use new vocabulary. The result is an approach to vocabulary learning that reinforces understanding of word meaning and helps students take ownership of new words.

The Heinle Picture Dictionary is adaptable to a variety of situations and purposes. Appropriate for both classroom and self study, *The Heinle Picture Dictionary* can be used as a stand-alone vocabulary and language learning resource or, using the array of available ancillaries, as the core of *The Heinle Picture Dictionary* program.

Word Lists

The following list includes a few ideas that can be incorporated into the class to provide practice with the vocabulary:

- **Brainstorm to gather ideas.** With the books closed, ask students to brainstorm words they think might be in the lesson you are about to begin. Then have students check to see how many items they predicted correctly.
- **Check to see what the students already know.** As a class, ask students to cover the word lists and identify pictures by numbers.
- **Introduce vocabulary.** Present each word to the students. Ask them to listen to you or the audio and repeat. Help them with pronunciation and check for comprehension.
- **Quiz students.** Ask students to point to pictures that correspond to words you call out. *Or*, ask students to point to pictures that correspond to words embedded within a sentence or a paragraph that you read aloud.
- **Have students quiz each other.** Student A covers the word list and student B asks student A to point to the correct picture. *Or*, ask students to work in pairs to define the meaning of words in the list using their own words.
- **Play Bingo.** Ask students to choose any five words from the list and write them down on a piece of paper. Call out words to the class at random. When a student has a word on his/her list, he/she checks it off. The first student to check off every word on his/her list wins.
- **Classify.** Ask students to classify vocabulary on a chart or in a cluster diagram. Templates for many charts and diagrams are available on the *Activity Bank CD-ROM* or can be produced by the students.
- **Do a dictation.** Give students spelling tests, dictate the *Words in Context*, or dictate sentences containing vocabulary. This can also be done as a pairwork activity in which one student gives the words or sentences to another.
- **Have students create sentences/paragraphs.** Ask students to produce sentences or paragraphs using the vocabulary from the list.
- **Elicit more vocabulary.** Elicit from students additional vocabulary related to the theme of the lesson.
- **Encourage discussion.** Discuss the theme of the lesson, using the new vocabulary.
- **Provide real-life tasks.** Have students use the vocabulary in a real-life task, such as making floor plans, giving directions, giving instructions, completing forms, etc.

Words in Context

Words in Context introduces students to words from the word list in the context of a reading about the lesson topic. In addition to introducing vocabulary from the lesson in context, these readings offer a number of pedagogical possibilities.

They provide interesting information that can be used to stimulate classroom discussion. The readings can also be used for classroom dictations or as models for writing.

Words in Action

The *Words in Action* section provides students with multi-skill activities to practice and reinforce the vocabulary. These activities are especially useful as an application after the students become comfortable with the new vocabulary.

Word Partnerships

The *Word Partnerships* section provides students with common high-frequency collocations using words from the word list. It may be helpful to show pictures or bring in real-life examples of the noun and adjective-based collocations, or to “perform” verb-based collocations for the class. Many of the “Word List” activities suggested above would work equally well with *Word Partnerships*.

Teaching Grammar with *The Heinle Picture Dictionary*

The scenes in *The Heinle Picture Dictionary* can be used as an effective tool for practicing grammar tenses. The following is an approach to using the dictionary to teach grammar.

Tell students to look at a scene in one of the lessons. Identify a time frame. For example, if you’re teaching present continuous, tell the students to imagine that everything in the scene is happening now.

1. Identify the context—usually a story, a class discussion, or a task can work well here. Avoid correcting students at this point.
2. Reveal the objective. Let the students know the particular grammar point you will focus upon.
3. Present the structure using a simple chart. Remember to keep the context in mind.
4. Ask students to describe the picture, using the target tense. As an additional challenge, you may have students ask each other questions about the illustration.
5. Provide either written or oral practice.
6. Evaluate students’ use and comprehension of the structure.
7. Provide an application that allows students to use the structure in a more independent and less guided way.

The same scene can be used over and over again to teach different tenses. The next time the scene is used to teach or review a tense, students will already be familiar with the vocabulary, so it will be easier for them to focus on the grammar.

Supplemental Materials

The Lesson Planner. The full-color *Lesson Planner* provides complete lesson plans at three different levels for each lesson in the dictionary. The levels are coded as follows:

- ★ = Beginning Low
- ★★ = Beginning
- ★★★ = Beginning High/Intermediate Low

Classes often differ in exact level, so please consider these levels only as suggestions. They are primarily given to indicate the increasing difficulty of the lessons.

The lesson plans take the instructor through each stage of a lesson, from warm-up, introduction, and presentation through to practice and application. The *Lesson Planner* includes the *Activity Bank CD-ROM*, which has additional activities for each unit. These worksheets can be downloaded and customized by the instructor.

Each of the three lesson plans provided for every lesson in *The Heinle Picture Dictionary* is designed to be used in a full class period. This planner is different from a traditional teacher’s guide in that it not only gives suggestions for what to do with the student material, but it also helps you to organize your entire class experience into a proven and productive lesson plan approach. The objective-driven lesson plans propose a variety of tasks and activities that culminate in an application and often an optional project.

As you incorporate lesson plans into your instruction, you will discover how this approach ensures effective teaching and successful language learning. The lesson plan format consists of the following:

- **Warm-up and Review**—Students are given tasks or activities that will activate their prior knowledge, preparing them for the lesson.
- **Introduction**—Students are given the objective for the lesson. This is an essential step as students must know what it is they will be learning and why they will be learning it.
- **Presentation**—Teachers present new material, check student understanding, and prepare students for the practice.
- **Practice**—Students practice an activity provided by the teacher.
- **Evaluation**—The teacher checks the students’ ability to do the previous practice as an indication of their readiness to perform the application.
- **Application**—Students demonstrate their ability to perform the objective of a lesson more independently, with less teacher guidance.

The HPD Workbooks. There are two HPD Workbooks, each with its own supplemental audio program. There will be one for beginning and the other for intermediate students. The full-color workbooks are correlated page by page to the dictionary. They have a variety of activities, including listening activities, to support student learning.

The HPD Interactive CD-ROM. This interactive CD-ROM provides an abundance of interactive activities to reinforce the vocabulary learned in *The Heinle Picture Dictionary*.

The HPD Audio Tapes and CDs include the readings and word lists.

We hope *The Heinle Picture Dictionary* becomes a source of engaging, meaningful language learning for your students. Please feel free to contact us at www.heinle.com with your comments and suggestions.

Welcome to

THE HEINLE PICTURE DICTIONARY

Four thousand words are presented in 16 contextualized, thematic units. Each lesson in the unit presents vocabulary through color photographs and illustrations, contextualized readings, high-frequency word patterns study, and active learning opportunities.

“Words in Context” shows how the language is actually used through accessible, contextualized readings at a high-beginning level.



Tools and Supplies 1

Words in Context

I go to hardware stores a lot because I work in construction. I keep my wrench, my hammer, and my screwdriver in my tool belt. Those are the tools I use the most.

Hand Tools



1 utility knife	7 file	13 vise
2 C-clamp	8 caulking gun	14 chisel
3 wedgehammer	9 hammer	15 pliers
4 shovel	10 wrench	16 level
5 axe	11 hacksaw	17 ruler
6 hand saw	12 tool belt	18 screwdriver

Electrical



Plumbing



19 electrical tape	25 pipe wrench
20 extension cord	26 pipe
21 wire	27 router
22 lightbulb	28 drill
23 wire stripper	29 drill bit
24 (pipe) fittings	30 blade
	31 circular saw
	32 power sander

Word Partnerships

a tool	bench
a Phillips	box
a fairhead	screwdriver
an electric	drill
a cordless	

Words in Action

1. Which items on the list have you used? What job did you do with each item?
2. Which tools would you use to:
 - build a bookcase?
 - wire a house?
 - install a sink?

160
161

“Word Partnerships” expands students’ use and understanding of high-frequency word patterns and collocations.

“Words in Action” gives critical thinking activities designed to help students put the vocabulary into meaningful use.

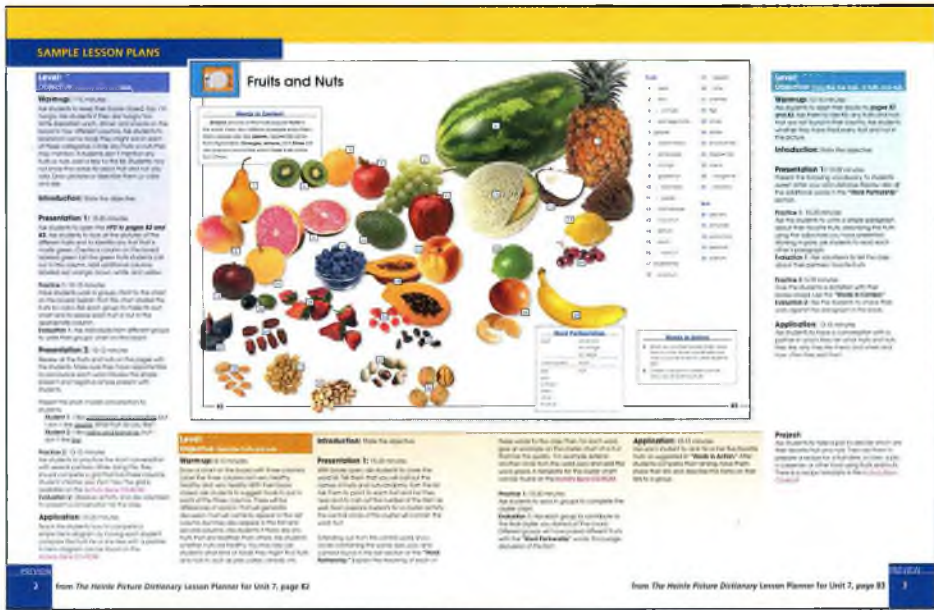

- The full-color **Lesson Planner** includes over 300 fully developed lesson plans that provide extensive support for the busy teacher.

The **Lesson Planner** provides lesson plans at three levels for each lesson in the dictionary. The lessons are coded as follows:

- ★ = Beginning Low
- ★★ = Beginning
- ★★★ = Beginning High/Intermediate Low

- **The Activity Bank CD-ROM** (included with the **Lesson Planner**) contains reproducible activity masters that can be customized for individual and classroom use.
- **The Heinle Picture Dictionary Workbooks**, beginning and intermediate, emphasize vocabulary and listening skills. Each workbook has its own audio program.
- **The Heinle Picture Dictionary Interactive CD-ROM** offers additional vocabulary practice through activities, games, and word webs.



Numbers

Words in Context

Some cultures have special birthdays. In Mexico, a girl's **fifteenth** birthday is special. She has a party called the *quinceañera*. In Japan, **twenty** is the beginning of adulthood. In Japan, people celebrate their **twentieth** birthday on January 15, the Day of Adults. In Thailand and Korea, the **sixtieth** birthday is the most important one.



zero



one



two



three



four



five



six



seven



eight



nine



ten



eleven



twelve



thirteen



fourteen



fifteen



sixteen



seventeen



eighteen



nineteen



twenty

twenty-one

30

thirty

40

forty

50

fifty

60

sixty

70

seventy

80

eighty

90

ninety

100

one hundred

1,000

one thousand

10,000

ten thousand

100,000

one hundred thousand

1,000,000

one million

Word Partnerships

an odd number

an even

a lucky number



Fractions

$\frac{1}{4}$ = one-quarter / a quarter



$\frac{1}{2}$ = one-half / a half



$\frac{2}{3}$ = two-thirds



$\frac{3}{4}$ = three-fourths / three quarters



Words in Action

1. Work in a group. Practice reading the following:
 - 25 minutes / 62 students / 98 pages
 - 12th birthday / 16th floor / 21st of May
2. Work with a partner. Ask and answer these questions:
 - What's your street address?
 - What's your phone number?



Time

Words in Context

I usually get up at about eight o'clock. But sometimes I like to get up before **dawn**. I love the quiet of the **sunrise**. About once a **month** I sleep until **noon**. On those days, there aren't enough **hours** in the day. **Night** comes much too soon.

Periods of time

a second



a minute



an hour



a day



a week

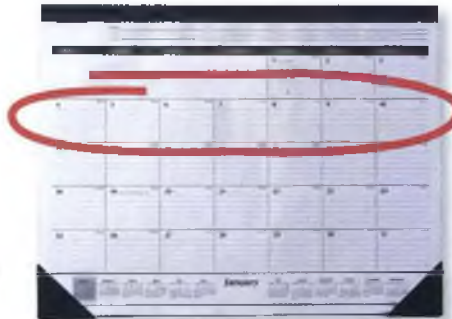

a month



a year

2001 - 2002

a century

2001 - 2100

a decade

2001 - 2010

a millennium

2001 - 3000

Times of day

sunrise / dawn



morning



noon / midday



afternoon



evening



sunset / dusk



night



midnight



Clock times



six o'clock



six twenty-five /
twenty-five past six /
twenty-five after six



six forty-five /
(a) quarter to seven /
(a) quarter of seven



six-oh-five /
five past six /
five after six



six-thirty /
half past six



six fifty-five /
five to seven /
five of seven



six fifteen /
(a) quarter past six /
(a) quarter after six



six thirty-five /
twenty-five to seven /
twenty-five of seven

Word Partnerships

at ten o'clock
night

in the morning
the evening

every day
once a week
month

this week
last month
next year

two hours ago
five months

Words in Action

1. What time do you usually get up? Have breakfast? Leave home in the morning? Have lunch? Go to bed?
2. What is your favorite time of day? Why? Discuss with a partner.



Calendar

1 date

2 yesterday

3 today

4 tomorrow

Days of the week

5 Monday

6 Tuesday

7 Wednesday

8 Thursday

9 Friday

10 Saturday

11 Sunday

Words in Context

The Month Poem

Thirty days has **September,**
April, June, and November.

All the rest have thirty-one

Except **February.**

February has twenty-eight most of the time,

But one year in four it has twenty-nine.



January 2005	February 2005	March 2005	
S M T W T F S	S M T W T F S	S M T W T F S	February 2005
1	1 2 3 4 5	1 2 3 4 5	
2 3 4 5 6 7 8	6 7 8 9 10 11 12	6 7 8 9 10 11 12	
9 10 11 12 13 14 15	13 14 15 16 17 18 19	13 14 15 16 17 18 19	
16 17 18 19 20 21 22	20 21 22 23 24 25 26	20 21 22 23 24 25 26	
23 24 25 26 27 28 29	27 28	27 28 29 30 31	
30 31			

5 Monday	January 31	8 Thursday	February 3
2			
6 Tuesday	February 1	9 Friday	February 4
3			
7 Wednesday	February 2	10 Saturday	February 5
4		11 Sunday	February 6

Weekdays	Weekend
----------	---------

Seasons

12 spring

13 summer

14 fall / autumn

15 winter

Months of the year

16 January

17 February

18 March

19 April

20 May

21 June

22 July

23 August

24 September

25 October

26 November

27 December

Word Partnerships

in March
April
(the) summer
(the) fall

on Monday
Tuesday
March 10
April 5



2005																											
16 January							17 February							18 March							19 April						
S	M	T	W	T	F	S	S	M	T	W	T	F	S	S	M	T	W	T	F	S	S	M	T	W	T	F	S
					1				1	2	3	4	5			1	2	3	4	5						1	2
2	3	4	5	6	7	8	6	7	8	9	10	11	12	6	7	8	9	10	11	12	3	4	5	6	7	8	9
9	10	11	12	13	14	15	13	14	15	16	17	18	19	13	14	15	16	17	18	19	10	11	12	13	14	15	16
16	17	18	19	20	21	22	20	21	22	23	24	25	26	20	21	22	23	24	25	26	17	18	19	20	21	22	23
23	24	25	26	27	28	29	27	28						27	28	29	30	31			24	25	26	27	28	29	30
30	31																										
20 May							21 June							22 July							23 August						
S	M	T	W	T	F	S	S	M	T	W	T	F	S	S	M	T	W	T	F	S	S	M	T	W	T	F	S
1	2	3	4	5	6	7				1	2	3	4						1	2	1	2	3	4	5	6	
8	9	10	11	12	13	14	5	6	7	8	9	10	11	3	4	5	6	7	8	9	7	8	9	10	11	12	13
15	16	17	18	19	20	21	12	13	14	15	16	17	18	10	11	12	13	14	15	16	14	15	16	17	18	19	20
22	23	24	25	26	27	28	19	20	21	22	23	24	25	17	18	19	20	21	22	23	21	22	23	24	25	26	27
29	30	31					26	27	28	29	30			24	25	26	27	28	29	30	28	29	30	31			
														31													
24 September							25 October							26 November							27 December						
S	M	T	W	T	F	S	S	M	T	W	T	F	S	S	M	T	W	T	F	S	S	M	T	W	T	F	S
				1	2	3						1				1	2	3	4	5					1	2	3
4	5	6	7	8	9	10	2	3	4	5	6	7	8	6	7	8	9	10	11	12	4	5	6	7	8	9	10
11	12	13	14	15	16	17	9	10	11	12	13	14	15	13	14	15	16	17	18	19	11	12	13	14	15	16	17
18	19	20	21	22	23	24	16	17	18	19	20	21	22	20	21	22	23	24	25	26	18	19	20	21	22	23	24
25	26	27	28	29	30		23	24	25	26	27	28	29	27	28	29	30				25	26	27	28	29	30	31
							30	31																			

Words in Action

1. What's your favorite season? Month? Day? Why? Discuss with a partner.
2. What are three dates that are important to you? These can be birthdays, anniversaries, or holidays. Discuss with a partner.



Money and Shopping

Words in Context

Be a smart **shopper**! Remember these things:

- Compare the **price** of the item you want in different stores.
- You can usually **return** or **exchange** items. Be sure to keep your **receipt**.
- Try to shop when there's a **sale**. You'll **save money**!



Coins

- 1 a penny / one cent / 1¢
- 2 a nickel / five cents / 5¢
- 3 a dime / ten cents / 10¢
- 4 a quarter / twenty-five cents / 25¢
- 5 a half dollar / fifty cents / 50¢

Bills

- 6 one dollar / a one-dollar bill / \$1
- 7 five dollars / a five-dollar bill / \$5
- 8 ten dollars / a ten-dollar bill / \$10
- 9 twenty dollars / a twenty-dollar bill / \$20
- 10 fifty dollars / a fifty-dollar bill / \$50
- 11 one hundred dollars / a one hundred-dollar bill / \$100

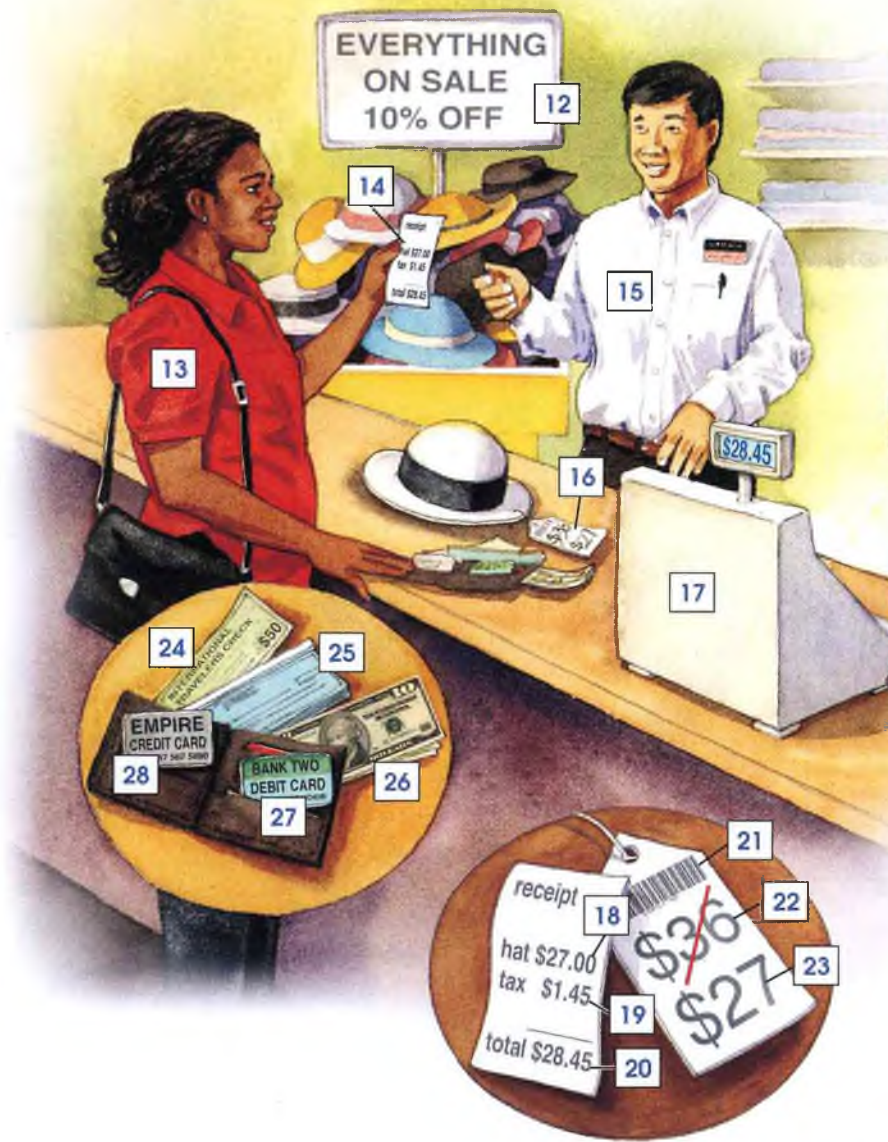

Verbs



29 windowshop



30 shop



31 buy



32 exchange



33 return



34 shop online

Shopping

12 a sale

13 a shopper

14 a receipt

15 a cashier

16 a price tag

17 a cash register

18 the price

19 the sales tax

20 the total

21 a bar code

22 the regular price /
the full price

23 the sale price

Methods of payment

24 a traveler's check

25 a (personal) check

26 cash

27 a debit card

28 a credit card

Word Partnerships

buy things on sale

pay by check
credit card

pay with a check
a credit card

pay (with) cash

save money
spend

Saying prices

\$1.25 = a dollar twenty-five
one twenty-five

\$10.50 = ten dollars and fifty cents
ten fifty

Words in Action

1. What do you pay for with a credit card? What do you pay for with a check? What do you pay for with cash? Discuss with a partner.
2. Do you have any bills in your pocket? Which ones? Do you have any coins? Which ones?



Colors

Words in Context

Colors can make us feel different ways. **Yellow** can make us happy. **Orange** can make us feel full of energy. **Black** can make us feel sad. **Blue** can make us feel calm.

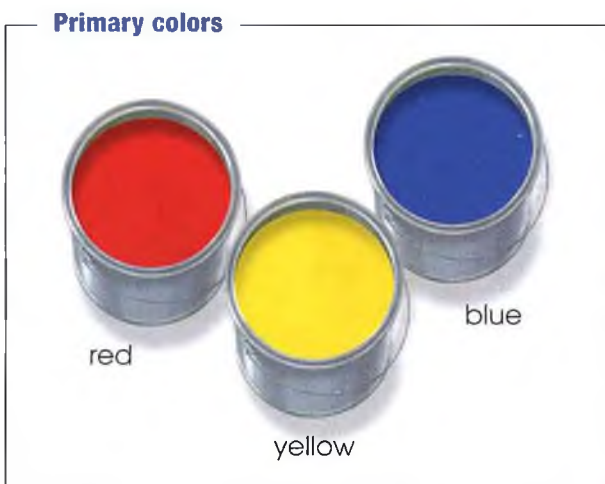
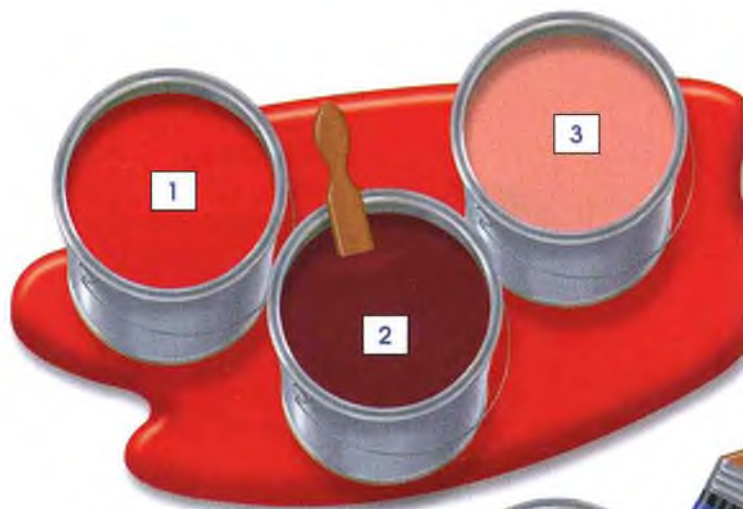

1 red

7 lime green

13 gold

19 orange

2 maroon

8 teal

14 purple

20 white

3 coral

9 blue

15 violet

21 cream / Ivory

4 pink

10 turquoise

16 brown

22 black

5 green

11 navy (blue)

17 beige / tan

23 gray

6 olive green

12 yellow

18 taupe

24 silver



Word Partnerships

light	pink	
dark	purple	
pale	gray	
	blue	
	green	

a	bright	color
	cheerful	
	rich	
	dull	

Words in Action

1. Look around the room. How many colors can you find? Make a list.
2. Work with a partner. Describe the color of one of your classmates' clothes. Your partner will guess the classmate.
 - Student A: *Someone is wearing green and blue.*
 - Student B: *It's Marcial*



In, On, Under

Words in Context

Look around you. Can you answer these questions?

- What's **in front of** you?
- What's **behind** you?
- What do you see **above** you?
- Is there someone or something **close to** you? Who or what?

Word Partnerships

right	under
	next to

Just	behind
	In front of
	to the left of
	above





- 1 This cat is on top of the shelves.
- 2 This cat is far from the other cats.
- 3 This cat is on a box.
- 4 This cat is between two boxes.
- 5 These kittens are in / inside a box.
- 6 This kitten is outside (of) the box.
- 7 This cat is jumping off the shelves.
- 8 This cat is on the left of / to the left of cat number 9.
- 9 This cat is on the right of / to the right of cat number 8.
- 10 This cat is above / over cat number 13.
- 11 This cat is next to / beside the shelves.
- 12 This cat has a ribbon around its neck.
- 13 This kitten is below / under cat number 10.
- 14 This kitten is behind the shelves.
- 15 This kitten is near / close to the shelves.
- 16 This kitten is underneath the shelves.
- 17 This cat is in front of the shelves.

Words in Action

1. Cover the list of words. Ask a partner questions like this:
 - *Where is cat number 10?*
2. Describe where things are in your classroom. Write ten sentences using ten different prepositions.



Opposites

Words in Context

Opposites sometimes attract. Women with **light** hair sometimes like men with **dark** hair. Very **tall** men sometimes marry very **short** women. **Thin** people sometimes fall in love with **heavy** people.

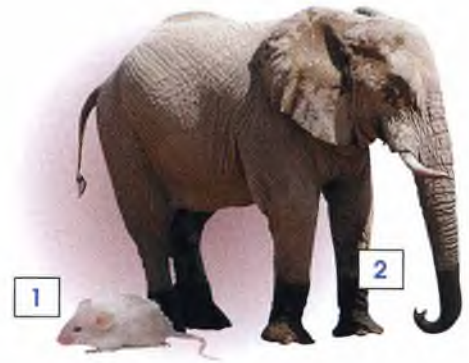

Word Partnerships

a cold	day
a hot	drink
	room
an open	window
a closed	door
	book
a clean	car
a dirty	dish
	room
a full	cup
an empty	stomach

- 1 small / little
- 2 big / large
- 3 strong
- 4 weak
- 5 dirty
- 6 clean
- 7 easy
- 8 difficult

- 9 hard
- 10 soft
- 11 alive
- 12 dead
- 13 ugly
- 14 beautiful
- 15 expensive
- 16 cheap

- 17 tall
- 18 short
- 19 full
- 20 empty
- 21 old
- 22 young
- 23 heavy
- 24 light

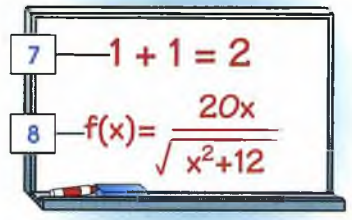

- 25 fat / heavy
- 26 thin
- 27 rich
- 28 poor
- 29 hot
- 30 cold
- 31 new
- 32 old
- 33 slow
- 34 fast
- 35 loud / noisy
- 36 quiet
- 37 open
- 38 closed / shut
- 39 man
- 40 woman

Words in Action

- Work in pairs. Say one of the words on the list. Your partner will say the opposite.
- Describe things that are the same or different about two people you know. Use words from the list.
 - *Leo and All are strong.*
 - *I'm tall. My brother is short.*



The Telephone

Words in Context

Do you want to make a **long-distance phone call** in the U.S.? **Pick up** the **receiver** and **dial** 1 + the **area code** + the **phone number**. Do you need **directory assistance**? You can dial **411**. Remember, there are four **time zones** in the U.S. When it is 9:00 P.M. in Los Angeles, it's midnight in New York!



- 1 a pay phone
- 2 a receiver
- 3 a calling card / a phone card
- 4 a coin
- 5 911 / emergency assistance
- 6 411 / information / directory assistance
- 7 a coin return
- 8 a telephone book / a phone book
- 9 a local call
- 10 a long-distance call
- 11 an international call
- 12 time zones
- 13 a caller
- 14 a phone jack
- 15 a cord
- 16 a headset
- 17 an operator
- 18 an answering machine
- 19 a cordless phone
- 20 a cell phone / a mobile phone
- 21 an antenna
- 22 an area code
- 23 a telephone number / a phone number



Verbs



24 pick up the phone



25 dial a number



26 hear the phone ring



27 answer the phone



28 have a conversation



29 hang up the phone

Word Partnerships

make	an international call
	a long-distance call
	a local call

call	directory assistance
	911

look up	a phone number
---------	----------------

telephone	company
	service
	bill



Words in Action

1. What is your area code and phone number?
2. How often do you make local, long-distance, and international calls? Who do you call? Why? Discuss with a partner.



Classroom

Words in Context

What does the ideal **classroom** look like? Some experts think that a classroom should look friendly. It should have comfortable **seats** and **desks**. It should have a large **bookshelf** with many **books**. It should also have bright **posters** and **bulletin boards** to show **students'** work.

Verbs



31 cheat on a test



32 fail a test



Word Partnerships

go to the board
write on
erase

a high school student
a college
an international
a graduate

a hard / difficult test / exam
an easy
a midterm
a final



33 study for a test



34 take a test



35 pass a test



13



12

14

15

16

27

17

28

29

18

30

- | | |
|-------------------------|--|
| 1 the alphabet | 14 a (white)board |
| 2 a teacher | 15 a marker |
| 3 chalk | 16 an overhead projector |
| 4 a (blackboard) eraser | 17 a table |
| 5 a homework assignment | 18 a workbook |
| 6 a (black)board | 19 a pen |
| 7 a bulletin board | 20 a pencil |
| 8 a flag | 21 a desk |
| 9 a globe | 22 an eraser |
| 10 a bookshelf | 23 a poster |
| 11 a book | 24 a cassette player / a tape recorder |
| 12 a map | 25 a student |
| 13 a clock | 26 a chair / a seat |
| | 27 a notebook |
| | 28 a grade |
| | 29 a test / an exam |
| | 30 a textbook |

Words in Action

1. Work with a group. Make a list of everything in your classroom. Which group has the longest list?
2. Cover the word list. Find one word in the picture that starts with each of the following letters: a, b, c, d, e, f, g, h.



Listen, Read, Write

Words in Context

People learn languages in different ways. Some students like to **listen** to the language. Others like to **write** lists of words. Others like to **read** a lot or **talk** with a group and **discuss** their ideas. What about you? How do you learn languages best?



1 raise your hand

2 hand in your paper

3 collect the papers

4 copy the sentence

5 exchange papers

6 write your name

7 read

8 look up a word
(in the dictionary)

9 close your book

10 open your book

11 discuss your ideas

12 listen

13 spell your name

14 take a break

15 sit down

16 go to the board

17 erase the board



- 22 Match** the items.
1. 3 ~~four~~
4 ~~three~~
- 23 Cross out** the wrong answers.
1. $2+2=$ ~~3~~ 4 ~~5~~
- 24 Check** the correct answer.
1. $2+2=$ 3 ~~4~~
- 25 Correct** the mistake.
1. $2+2=$ ~~3~~ 4
- 26 Fill in** the blank.
1. $2+2=$ 4
- 27 Underline** the correct answer.
1. $2+2=$ 3 4 5
- 28 Circle** the correct answer.
1. $2+2=$ 3 (4) 5
- 29 Darken** the correct oval.
1. $2+2=$ 3 4

- 18** hand out papers
- 19** stand up
- 20** talk with a group
- 21** share a book
- 22** match
- 23** cross out
- 24** check
- 25** correct
- 26** fill in
- 27** underline
- 28** circle
- 29** darken

Word Partnerships

read	silently
	aloud / out loud
	to your partner
discuss	with a partner
	with a group
listen	to me
	carefully
	to your partner
	and repeat

Words in Action

- Take turns giving and following classroom instructions. For example, one person says: *Stand up*. The other person stands up.
- Which activities do you often do in class? Make a list.



School

Words in Context

In the U.S., a **principal** manages the school. **Guidance counselors** help students plan their **schedules**. Students take home **report cards** a few times a year, and parents must sign them. Many students participate in **extracurricular activities** such as **drama clubs** or **sports**.



Word Partnerships

- elementary school
- middle
- high
- join a team
- a club

1st Semester	Monday	Tuesday
8:00–9:25	25 ogy	Biolog
9:25–10:20	Orchestra	Histor
10:20–10:40	Study Hall	Breath
10:40–11:00	Break	Study H
11:00–11:55	Spanish I	Spanis
11:55–12:30	Lunch	Lunch
12:30–1:25	English II	Englis
1:25–2:20	Algebra	Algebr

George Washington High School
1st Semester Grade Report

To the Parents of: **James # 24**

HR	SUBJECT	TEACHER	1	EXAM	2	EXAM
1	Biology	Stephens	B-	B	C+	C
2	English 2	Geofferies	A	A	A	A
3	Intro Journal	Bennett	A	A	A	A-
4	Seminar	Hurst	CR		CR	
5	Algebra 2	Jakobe	F	D	D+	C

1 a coach

2 a team

3 a language lab

4 a gym

5 bleachers

6 a cafeteria

7 a (school) library

8 a school nurse

9 a teachers' lounge

10 a restroom /
a bathroom

11 a water fountain

12 a school bus

13 a loudspeaker

14 a locker

15 a backpack

16 a principal

17 a guidance
counselor

18 an auditorium

19 a graduation

20 a classroom

21 sports

22 Spanish club

23 drama club

24 a report card

25 a (student) schedule

26 a permission slip

27 an absence note



Wednesday	Thursday	Friday
Biology	Biology	Biology
Phys. Ed	History	History
Study I		
Breast		
Orchestra		
Lunch		
English		
Algebra		

27
Mrs. Gunther,
My son, Luiz, was absent on Tuesday
and Wednesday because of the flu.

Sincerely,
Mrs. Sanchez

I give permission for my child Jim Brown
to go on the museum field trip on 11/15/05.

Jane Brown
(Parent or Guardian)

26

Words in Action

1. Think of a high school you know. Describe it to a partner.
2. Compare this high school with your high school or a high school in your town.
 - In Turkey, our high school auditorium was outdoors.



Computers

Words in Context

Computers keep getting smaller and faster. Scientists built the first computer in the 1940s. It was the size of a large room. In the 1970s, stores began to sell **desktop computers**. Then, in the 1990s, small **laptops** appeared. Now tiny **handheld computers** are popular.

Verbs



30 be online



31 enter your password



32 select text



33 click



34 scan



35 print (out)

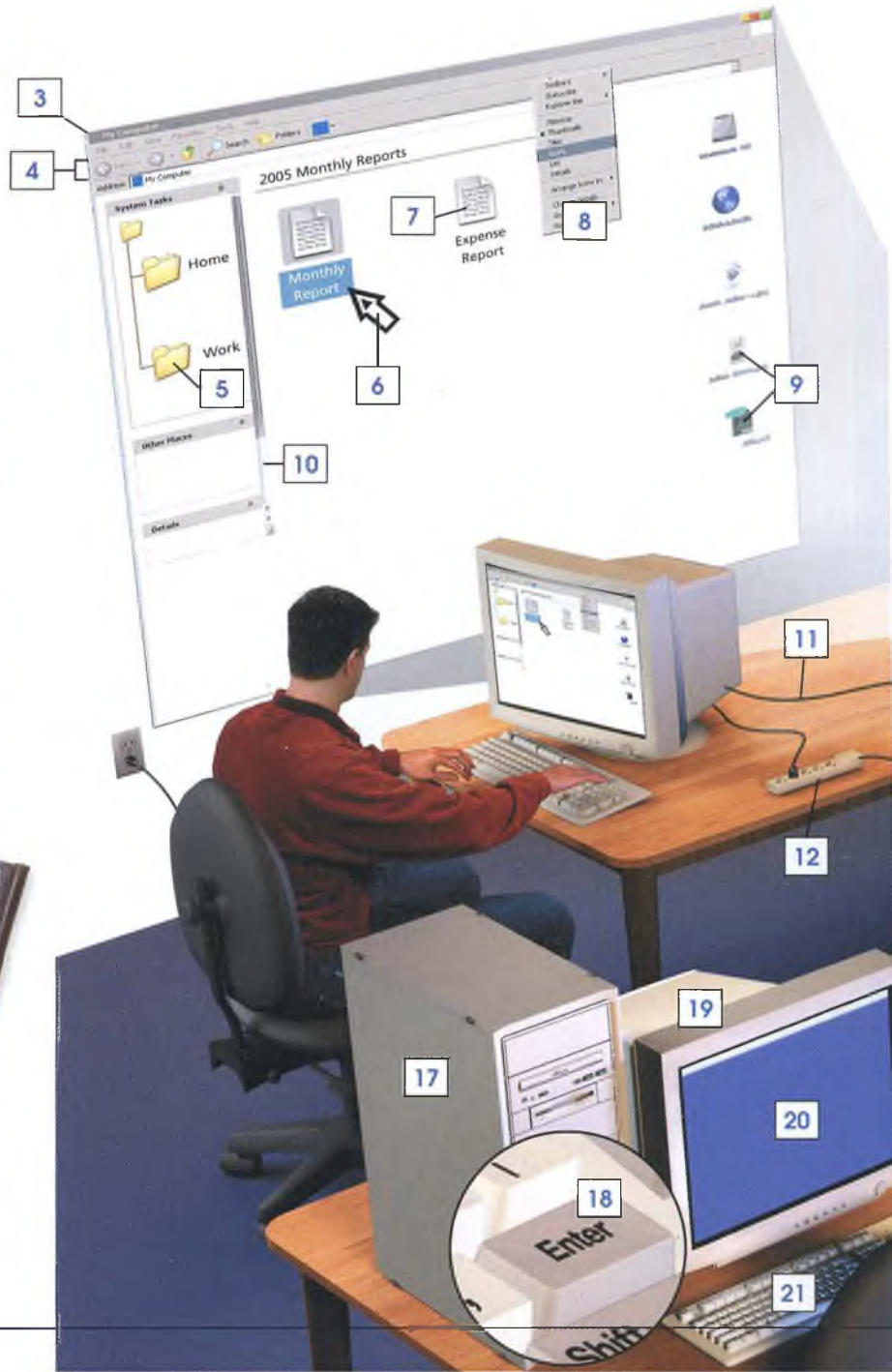

16



Family

Words in Context

Children often look more like one parent than the other. Maybe you have your mother's eyes, your father's hair, your grandmother's skin color, or your grandfather's lips. Who do you look like?



1 2



3 4



5 6



11



12



13



14 15



19



20



23

24



25

26

18



27 be married



28 be divorced

- 1 grandfather
- 2 grandmother
- 3 aunt
- 4 uncle
- 5 stepmother
- 6 father
- 7 mother
- 8 stepfather
- 9 mother-in-law
- 10 father-in-law
- 11 cousin
- 12 stepsister
- 13 half sister
- 14 brother-in-law
- 15 sister
- 16 sister-in-law
- 17 brother
- 18 husband
- 19 niece
- 20 nephew
- 21 son
- 22 daughter
- 23 grandchildren
- 24 grandparents
- 25 parents
- 26 wife

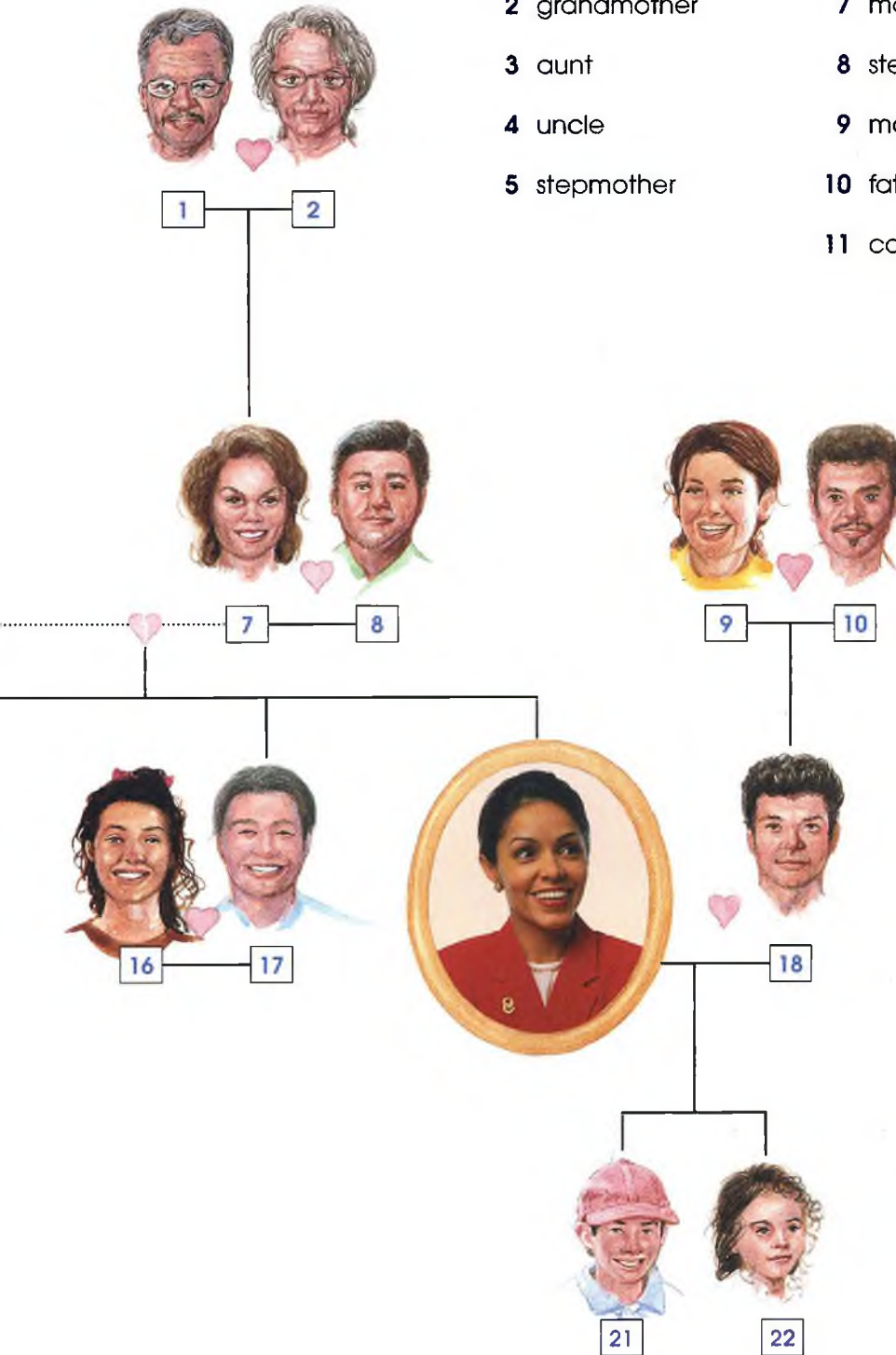

Word Partnerships

- | | |
|-----------|---------|
| a first | wife |
| a second | husband |
| an ex- | |
| an older | brother |
| a younger | sister |

Words in Action

1. Which members of your family look alike?
 - I look like my sister.
 - My brother looks like my father.
2. Draw a family tree or bring pictures to class. Tell a partner about your family.



29 be a single mother



30 be remarried



Raising a Child

Words in Context

Everyone loves to **hold** and **rock** a baby. But it takes time and energy to **love**, **protect**, and **encourage** children. It also costs a lot of money to **raise** them. The average family in the U.S. spends \$160,000 to raise a child to the age of 18!

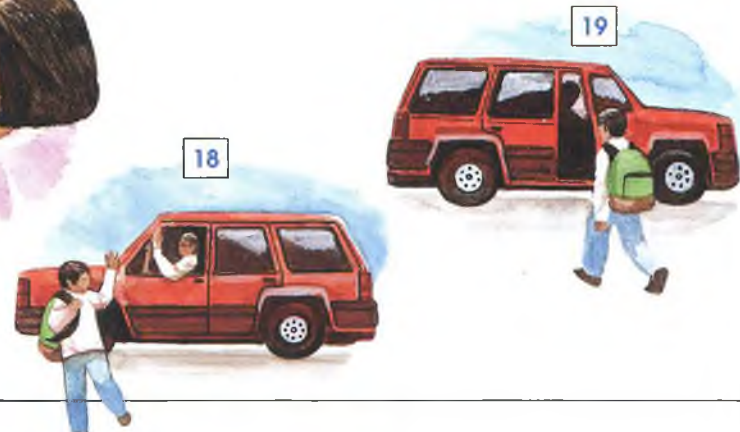



2

1 love him

17 praise him



3

2 nurse him

18 drop him off



4

3 rock him

19 pick him up

4 hold him

20 read to him

5 feed him

21 put him to bed

6 carry him

7 bathe him

8 change his diapers

9 play with him

10 pick him up

11 dress him

12 comfort him

13 discipline him

14 protect him

15 encourage him

16 help him

Word Partnerships

grow (up)	fast
	quickly
read	a book
	a story

Verbs



9



22 crawl



23 cry



10



24 behave



25 misbehave



20



26 grow

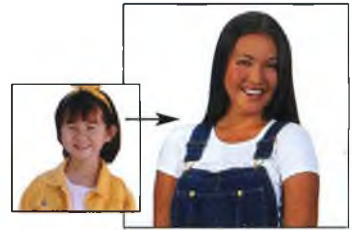

27 grow up



21

Words in Action

- Write a list of "Rules for Parents." Share your rules with the class.
 - Parents must always protect their children.
- Talk with a group. What are the ten most important things to do for a child? Make a list. Put the most important things first.



Life Events

Words in Context

The Life of Princess Diana

1961
Princess Diana is born.

1980
Diana falls in love with Prince Charles.

1981
Diana and Charles get married.

1982
Diana has a baby, Prince William.

1984
Diana has another baby, Prince Henry.

1996
Charles and Diana get divorced.

1997
Diana dies in a car accident.

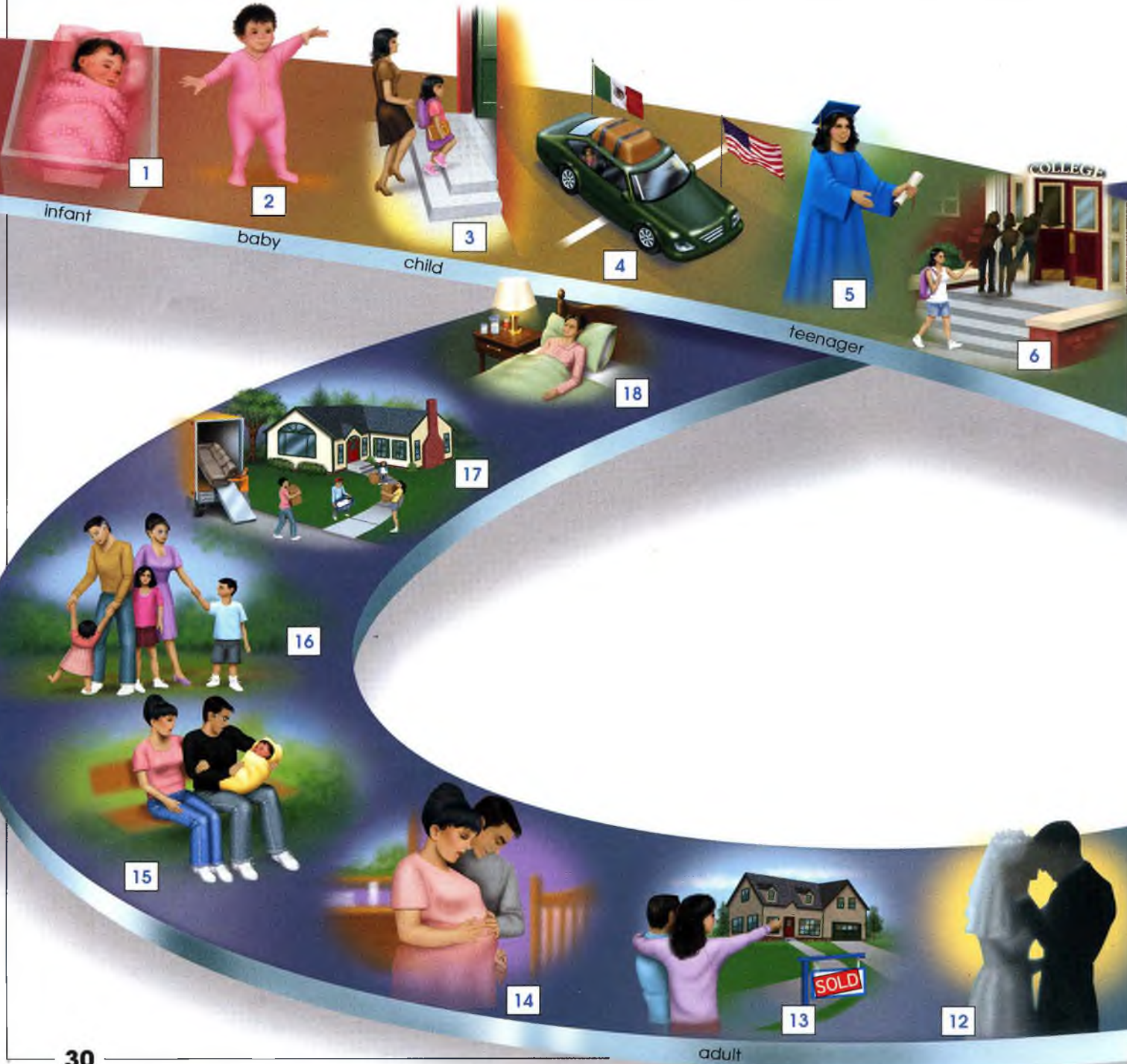

- | | | |
|-----------------------------|-------------------|-------------------------|
| 1 be born | 9 date | 17 move |
| 2 learn to walk | 10 fall in love | 18 get sick |
| 3 start school | 11 get engaged | 19 take a vacation |
| 4 immigrate | 12 get married | 20 celebrate a birthday |
| 5 graduate from high school | 13 buy a house | 21 become a grandparent |
| 6 go to college | 14 be pregnant | 22 retire |
| 7 rent an apartment | 15 have a baby | 23 travel |
| 8 get a job | 16 raise a family | 24 die / pass away |

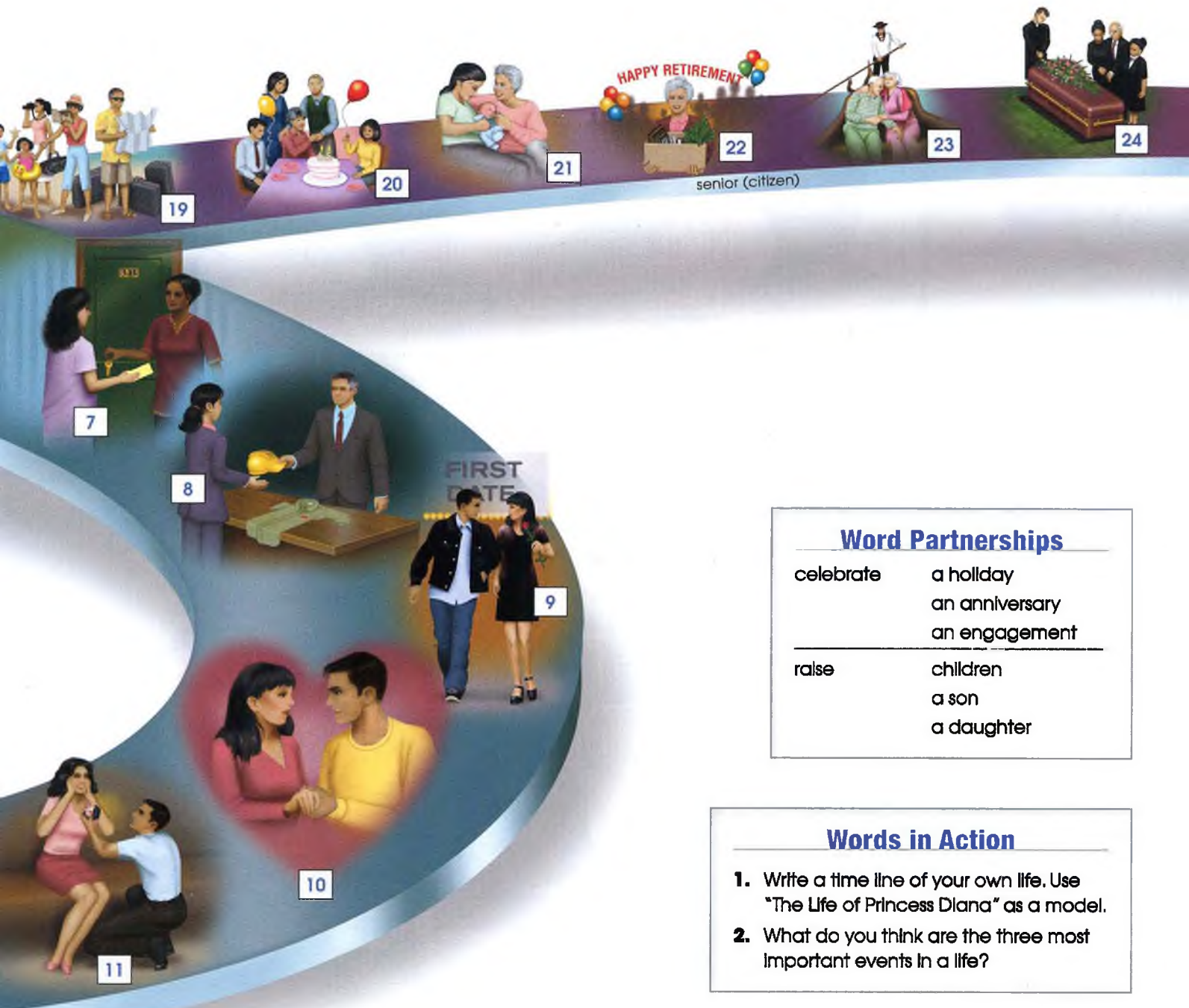

Word Partnerships

celebrate	a holiday
	an anniversary
	an engagement

raise	children
	a son
	a daughter

Words in Action

1. Write a time line of your own life. Use "The Life of Princess Diana" as a model.
2. What do you think are the three most important events in a life?



Face and Hair

Words in Context

The way people wear their hair changes often. One year, **long hair** is the fashion for women. The next year, it is **short hair**. Sometimes **curly hair** is popular. But then soon everyone wants **straight hair**. Men's fashions change too. Sometimes **sideburns** are long and sometimes they are short. **Beards** and **mustaches** come and go.

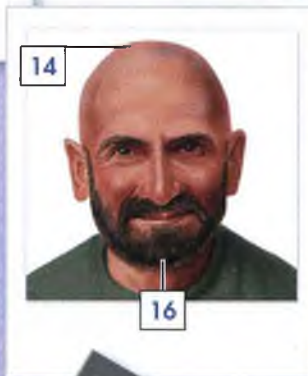
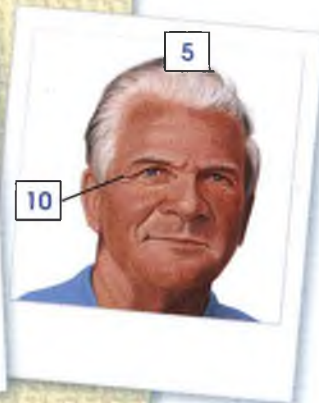

Word Partnerships

a friendly face
a happy face
a pretty face

thin hair
thick hair

reading glasses
prescription glasses

- 1 red hair
- 2 brown hair
- 3 black hair
- 4 blond hair
- 5 gray hair
- 6 freckles
- 7 a scar
- 8 a mustache
- 9 a dimple
- 10 a wrinkle
- 11 short hair
- 12 shoulder-length hair
- 13 long hair
- 14 bald
- 15 sideburns
- 16 a beard
- 17 straight hair
- 18 curly hair
- 19 wavy hair
- 20 pierced ears
- 21 braids
- 22 a bun
- 23 bangs
- 24 a ponytail
- 25 cornrows
- 26 pigtails
- 27 a mole
- 28 glasses



Words in Action

1. Compare yourself with a partner.
 - ☒ We both have short hair.
 - ☒ I have freckles. Alex doesn't.
2. Work with a partner. Take turns describing the face of someone you know. The other person will draw the face.



Daily Activities

Words in Context

José and I have two children and we both work. Our lives are busy. I usually wake up early. I go to work at 6:00 A.M. I'm a clerk at a market. José wakes the kids up and takes them to school. I go home at noon and have lunch. Then José goes to work. I do the housework and make dinner. The children go to bed before José returns at 10:00 P.M. The next day we get up and do it all again!

- | | |
|----------------------------------|-----------------------------|
| 1 wake up | 19 eat dinner / have dinner |
| 2 get up | 20 take a walk |
| 3 brush your teeth | 21 do housework |
| 4 take a shower | 22 take a bath |
| 5 comb your hair | 23 go to bed |
| 6 shave | 24 sleep |
| 7 put on makeup | 25 watch television |
| 8 get dressed | |
| 9 eat breakfast / have breakfast | |
| 10 take your child to school | |
| 11 go to work | |
| 12 take a coffee break | |
| 13 eat lunch / have lunch | |
| 14 go home | |
| 15 take a nap | |
| 16 exercise / work out | |
| 17 do homework | |
| 18 make dinner | |



Words in Action

- Take turns asking and answering questions about the picture.
 - Student A: *What does the family do in the morning?*
 - Student B: *They wake up, get dressed, and eat breakfast.*
- Tell your partner about your typical morning.
 - I wake up at 9:00. First I brush my teeth and then I take a shower.*





Walk, Jump, Run



Words in Context

I live in Los Angeles. What a busy place it is! I often **run** because I am always late. I have to **get on** the bus at 8:00 in order to arrive at work by 9:00. There is a lot of traffic. It is probably faster to **walk**. But I study English while I **ride** the bus. I am learning a lot!



- | | | | | |
|-----------------|-----------|---------------|------------|---------|
| 1 fly | 7 fall | 13 walk | 19 go down | 24 jump |
| 2 leave | 8 slip | 14 get off | 20 go up | 25 push |
| 3 enter / go in | 9 jog | 15 stand up | 21 crawl | 26 ride |
| 4 march | 10 cross | 16 sit (down) | 22 kneel | 27 pull |
| 5 get out (of) | 11 run | 17 follow | 23 squat | |
| 6 get in | 12 get on | 18 lead | | |



Word Partnerships

fall	off
jump	down
	over
get in	a car
get out of	a taxi
get on	a train
get off	a bus
ride	a bicycle / a bike
	a motorcycle
	a horse
cross	the street

Words in Action

1. What five things do you do every day? Use words from the list.
2. Take turns acting out some of the verbs on the list. The other students will guess what you are doing.



Feelings

- 1 proud
- 2 happy
- 3 angry
- 4 interested
- 5 calm
- 6 nervous
- 7 embarrassed
- 8 in love
- 9 full
- 10 hungry

Words in Context

People cry when they feel **sad** or **homesick**. Sometimes they also cry when they are **happy**, **angry**, or **scared**. People laugh when they are happy. Sometimes they also laugh when they are **nervous** about something.



11 thirsty

16 homesick

20 excited

24 comfortable

12 frustrated

17 lonely

21 sad

25 uncomfortable

13 bored

18 confused

22 surprised

14 sick / ill

19 afraid / scared

23 tired

15 worried

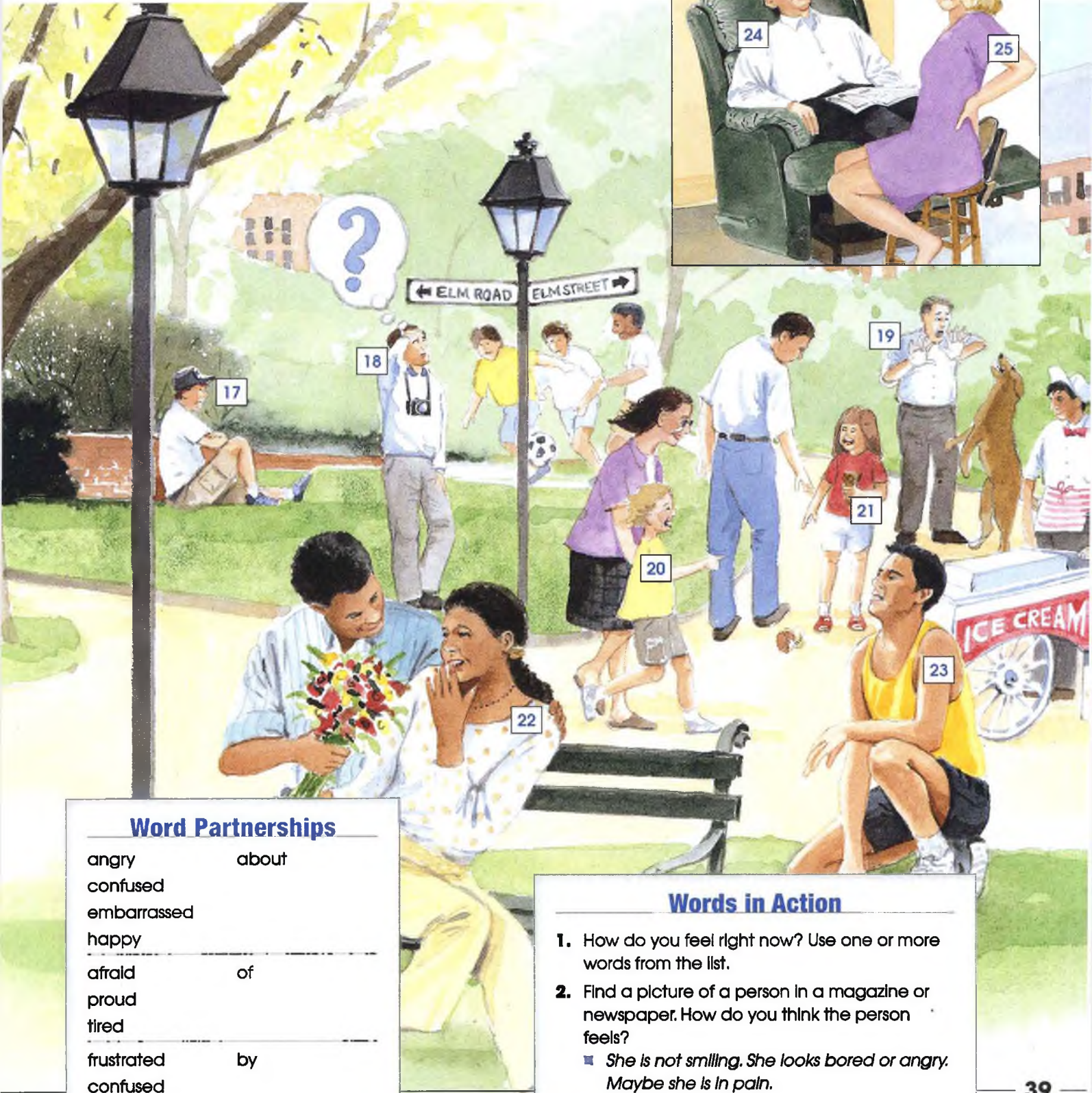

Word Partnerships

angry about

confused

embarrassed

happy

afraid of

proud

tired

frustrated by

confused

Words in Action

1. How do you feel right now? Use one or more words from the list.

2. Find a picture of a person in a magazine or newspaper. How do you think the person feels?

- She is not smiling. She looks bored or angry. Maybe she is in pain.



Wave, Greet, Smile

Words in Context

Ways to **greet** people differ from country to country. In the U.S., people often **shake hands** when they first meet. In Japan, people frequently **bow** to each other. In Chile, women often **hug** and **kiss** each other.



1 argue

9 apologize

17 hug

2 greet

10 compliment

18 smile

3 visit

11 agree

19 help

4 shake hands

12 disagree

20 wave

5 touch

13 comfort

21 kiss

6 have a conversation

14 bow

22 dance

7 give a gift

15 introduce

23 invite

8 write a letter

16 call

24 congratulate



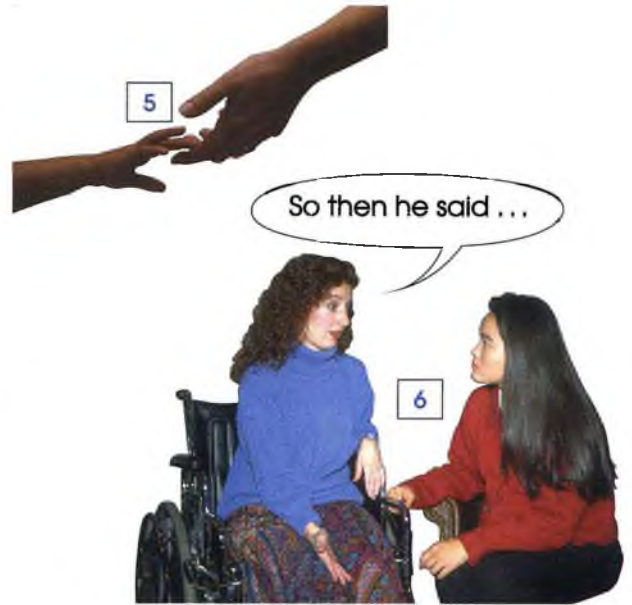
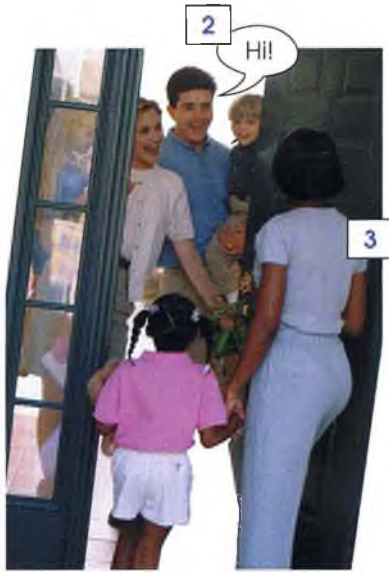

Word Partnerships

agree with
 dance
 argue
 apologize to
 bow
 wave

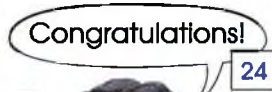

Words in Action

1. How do men and women in your culture greet someone new? How do they greet good friends? Family members?
2. Write five sentences about your best friend. Use words from the list.



Documents

Words in Context

There are **documents** for almost every important event in life. When you are born, you get a **birth certificate**. When you graduate from school, you get a **diploma**. You get a **driver's license** when you are ready to drive. You apply for a **passport** before you travel to another country. And you get a **marriage certificate** when you get married.

Personal Information (please print)

1 Name Hong 2 John 3 E 4
LAST FIRST MIDDLE INITIAL

5 Sex Male Female

6 Date of birth 6 / 21 / 1960
MONTH DAY YEAR

7 Place of birth Los Angeles, CA

8 Soc. Sec. No. 135-XX-2887

9 Telephone No. 415 / 555-8765
AREA CODE

10 E-mail jhong@bower.com

Address

11 452 Austin St.
STREET
San Jose CA 95112
CITY STATE ZIP

15 John E Hong
SIGNATURE



A (registration) form

- 1 name
- 2 last name / surname / family name
- 3 first name
- 4 middle initial
- 5 sex / gender
- 6 date of birth
- 7 place of birth
- 8 Social Security number
- 9 telephone number
- 10 e-mail address
- 11 street address
- 12 city
- 13 state
- 14 zip code
- 15 signature

Documents

- 16 a vehicle registration card
- 17 a Resident Alien card / a green card
- 18 a driver's license
- 19 a student ID
- 20 a business card
- 21 a Social Security card
- 22 a passport
- 23 a visa
- 24 a birth certificate
- 25 a marriage certificate
- 26 a Certificate of Naturalization
- 27 a college degree
- 28 a high school diploma

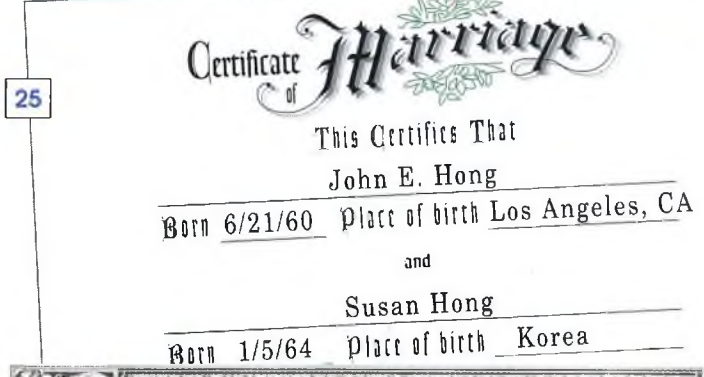

22



Word Partnerships

apply for	a passport
get	a marriage license
have	a green card
sign	your name
print	
say	
fill in / fill out	a form
an application	form
an order	

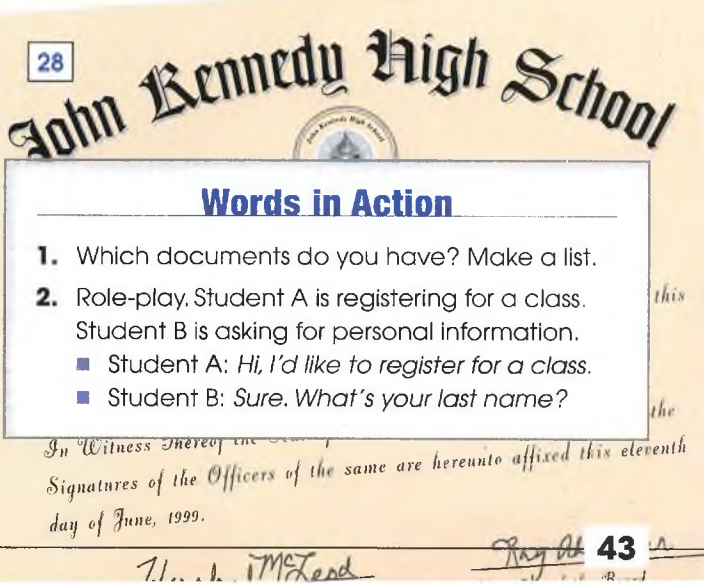
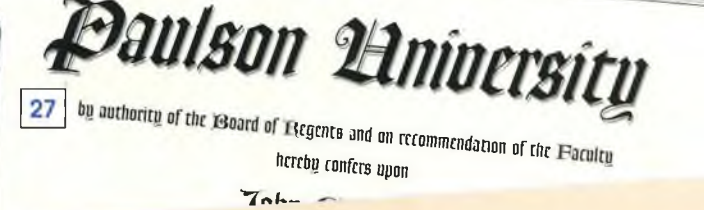

- Words in Action**
1. Which documents do you have? Make a list.
 2. Role-play. Student A is registering for a class. Student B is asking for personal information.
 - Student A: Hi, I'd like to register for a class.
 - Student B: Sure. What's your last name?



Nationalities

Words in Context

Women from many different countries have been in space. In 1963 Valentina Tereshkova, a **Russian** woman, was the first woman in space. Sally Ride was the first **American** woman in space. Chiaki Mukai was the first **Japanese** woman in space. A **French** woman, a **Canadian** woman, and an **English** woman have also been in space.



- | | |
|---------------------------|------------------|
| 1 Canadian | 16 Turkish |
| 2 American | 17 Iranian |
| 3 Mexican | 18 Egyptian |
| 4 Venezuelan | 19 Saudi Arabian |
| 5 Colombian | 20 Nigerian |
| 6 Peruvian | 21 Russian |
| 7 Brazilian | 22 Indian |
| 8 Chilean | 23 Chinese |
| 9 Argentine / Argentinean | 24 Korean |
| 10 British | 25 Japanese |
| 11 German | 26 Thai |
| 12 French | 27 Vietnamese |
| 13 Spanish | 28 Filipino |
| 14 Italian | 29 Malaysian |
| 15 Greek | 30 Australian |





Words in Action

- With a partner, practice matching countries and nationalities. One person will say a country. The other will say the nationality. Take turns.
 - Student A: *Brazil*
 - Student B: *Brazilian*
- Do you have classmates or friends from other countries? Make a list of their nationalities.



Places Around Town

Words in Context

I come from Concon, a small town in Chile. There's a **church**, a **gas station**, a **school**, and a soccer **stadium**. There is no **mall**, no **hospital**, no **library**, and no **movie theater**. Concon is beautiful. There are **parks** in the town and beaches nearby. Sometimes I get homesick for my little town.



- | | | |
|---------------------|------------------------------|---------------------------|
| 1 a factory | 11 a theater | 21 a parking garage |
| 2 a stadium | 12 a movie theater | 22 a high-rise (building) |
| 3 a mall | 13 a church | 23 a car dealership |
| 4 a motel | 14 a post office | 24 a sidewalk |
| 5 a mosque | 15 an office building | 25 a corner |
| 6 a school | 16 a fire station | 26 an intersection |
| 7 a synagogue | 17 a city hall / a town hall | 27 a street |
| 8 a hospital | 18 a library | 28 a park |
| 9 a college | 19 a courthouse | |
| 10 a police station | 20 a gas station | |

Word Partnerships

- | | |
|---------------|--------|
| a narrow | street |
| a wide | |
| a dead-end | |
| a quiet | |
| a busy | |
| an elementary | school |
| a middle | |
| a high | |
| a public | |
| a private | |

Words in Action

- One person describes the location of a building in the picture. The other person guesses what the building is.
 - Student A: *It's between the city hall and the courthouse.*
 - Student B: *The library!*
- Which of the places on the list are in your town (or in the town closest to your home)?



Shops and Stores

Words in Context

Americans shop a lot before holidays. Before Thanksgiving, **supermarkets** sell a lot of food. Just before Christmas, **department stores** and **toy stores** are crowded. Around Valentine's Day, **florists** and **jewelry stores** are very busy.



- | | | |
|--------------------------|--|-----------------------------|
| 1 an electronics store | 11 a hair salon / a beauty salon | 21 a pet store |
| 2 a clothing store | 12 a barbershop | 22 a bakery |
| 3 a shoe store | 13 a health club / a gym | 23 a laundromat |
| 4 a gift shop | 14 a thrift shop / a second-hand store | 24 a fast food restaurant |
| 5 a jewelry store | 15 a copy shop | 25 a department store |
| 6 a sporting goods store | 16 a nail salon | 26 a drugstore / a pharmacy |
| 7 a toy store | 17 a (dry) cleaner | 27 a supermarket |
| 8 a furniture store | 18 a video store | 28 an ice cream stand |
| 9 a bookstore | 19 a flower stand | 29 a photo kiosk |
| 10 a music store | 20 a coffee shop | 30 a flea market |





Word Partnerships

shop at	a bookstore
work at	a jewelry store
manage	a music store
own	a bakery

Words in Action

1. You need bread, dog food, aspirin, a swimsuit, and a CD. Which stores will you go to?
2. What three stores in the picture do you most like to go to? Why? Tell a partner.



- 1 a safe-deposit box / a safety-deposit box
- 2 a security guard
- 3 a vault
- 4 a teller
- 5 a teller window
- 6 cash / money
- 7 a customer
- 8 a bank manager
- 9 a loan officer
- 10 a (monthly) statement
- 11 a checking account number
- 12 a checkbook
- 13 a check
- 14 a (savings account) passbook
- 15 Interest
- 16 a deposit
- 17 a withdrawal
- 18 a balance
- 19 a money order
- 20 an ATM
- 21 a drive-up window
- 22 an ATM card / a bankcard

Verbs



23 wait in line



24 insert your ATM card



25 enter your PIN



26 withdraw cash



27 make a deposit



28 remove your card

SAVINGS ACCOUNT				
NOTE	% INTEREST	DEPOSITS	WITHDRAWALS	BALANCE
Open account		\$500.00		\$500.00
Textbooks			\$75.00	\$425.00
Interest	\$3.21			\$428.21
Birthday gift from Mom		\$25.00		\$453.21
Interest	\$3.68			\$456.99

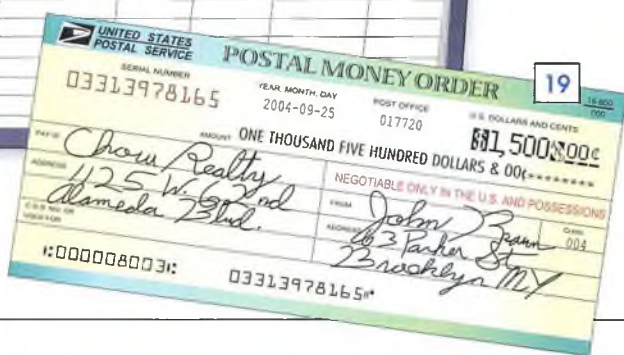

Words in Action

- When was the last time you went to the bank? What did you do there? What part of the bank did you go to? Who did you speak to?
- Work with a partner. One person says the steps to using an ATM. The other acts out the steps.



Post Office

Words in Context

Do you want the **mail** you **send** to arrive safely and on time? Be sure to use a **zip code** on every **letter** and **package**. Also be sure to use a **return address**. A **postal clerk** can **weigh** your mail so you will know how much **postage** to put on it.



1

Florida Electric Company
P.O. Box D, West Beach, FL 33845 • www.floridapower.com
See other side for explanation of terms and additional telephone numbers

Name: Maria Garcia
Address: 456 Stone St, Homeland, FL 33847

Account Number: 10A57-348-00124-3E

Rate (R)

Amount	Rate
5.92	
5.97	
11.79	
0.02	
0.09	
0.55	
0.67	
42.46	
11.10	
70.00	

Due date: 5/10/05

2

Summary of Transactions and Balance

Dear Elena,

Thanks for your letter. I was happy to hear from you. Everything is fine with me. I like my English class and I'm meeting many new friends. I'm living in a nice town. It has lots of good shops and stores. I am spending too much money!

How are you? How is your family? Write me again soon.

Love,
Maria



3

4

Maria Garcia
456 Stone St
Homeland, FL
33847

5

PIONEER • JUPITER
US
37c

6

Elena Ramirez
65 Oak Ave.
Pasadena, CA
91101

7

8

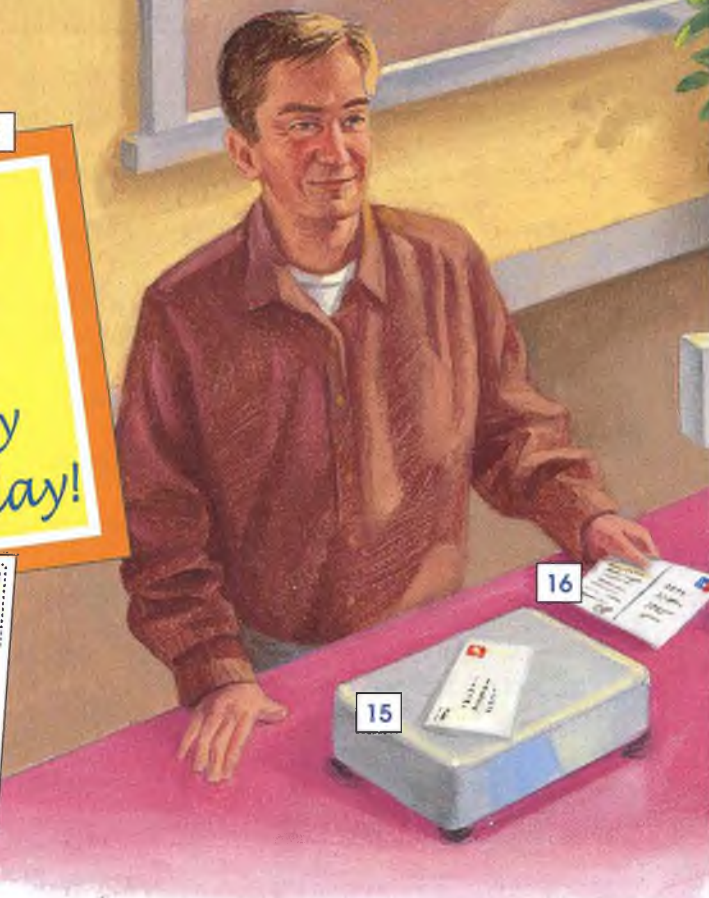

- | | | | |
|-----------------------|--------------------------------------|-----------------------------------|-----------------------------------|
| 1 a bill | 7 a zip code | 12 a stamp machine | 18 a postmark |
| 2 a letter | 8 an envelope | 13 a post office box / a P.O. Box | 19 overnight mail / next-day mail |
| 3 a greeting card | 9 a mailbox | 14 a catalog | 20 a (postal) clerk |
| 4 a (return) address | 10 a mail carrier / a letter carrier | 15 a (postal) scale | |
| 5 a stamp | 11 a mail truck | 16 a postcard | |
| 6 a (mailing) address | | 17 a package | |



Verbs



21 address

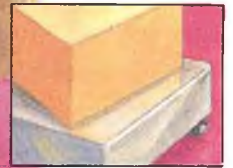

22 weigh



23 put a stamp on



24 mail / send

Word Partnerships

a business letter	
a personal letter	
a love letter	
a first class stamp	
a book of stamps	
a sheet of stamps	
a roll of stamps	
a postage-paid envelope	
a self-addressed stamped envelope	

Words in Action

1. What kinds of mail do you send? What kinds do you get? What is your favorite kind of mail to receive? What is your least favorite? Discuss with a group.
2. Describe your last visit to the post office. What did you do? Who did you talk to? What did you see? Tell your partner.



Library

Verbs



26 look for a book



27 check out books

Words in Context

Libraries can change people's lives. In 1953, **author** Frank McCourt arrived in New York City from Ireland. One day a man told Frank to go to a library. So Frank did. He got a **library card**, **checked out** a **book**, and fell in love with reading. All of the reading he did at the library helped Frank McCourt become a successful **writer**. Now people can read his **autobiography** in 30 different languages!

Reading Room

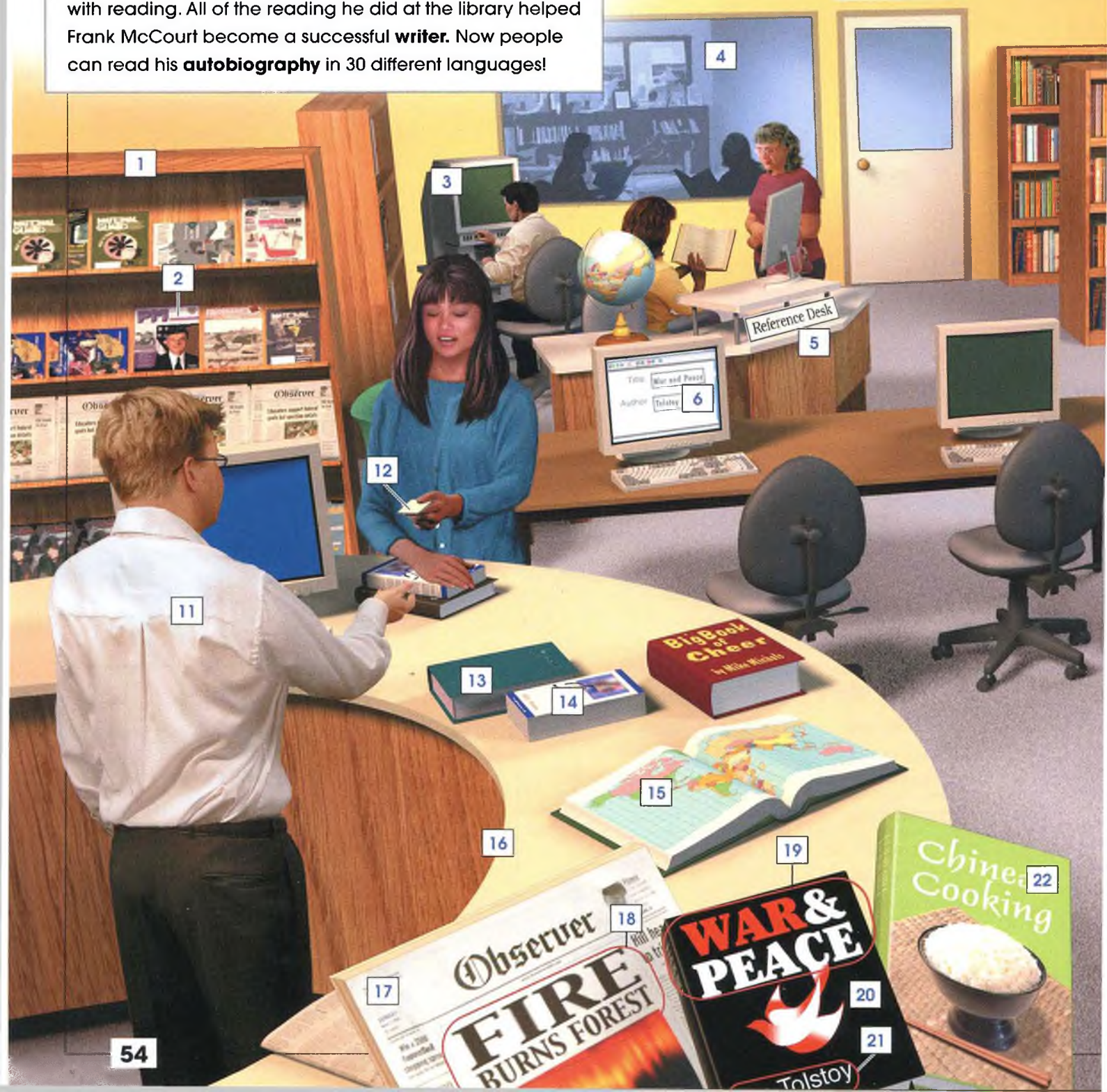

1

2

3

4

12

Reference Desk

5

11

Title: War and Peace
Author: Tolstoy

6

13

14

Big Book of Cheer
by Mike Michals

15

16

19

Observer
FIRE BURNS FOREST

17

18

WAR & PEACE
Tolstoy

20

21

Chinese Cooking

22



28 read

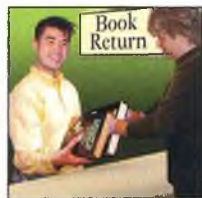

29 return books

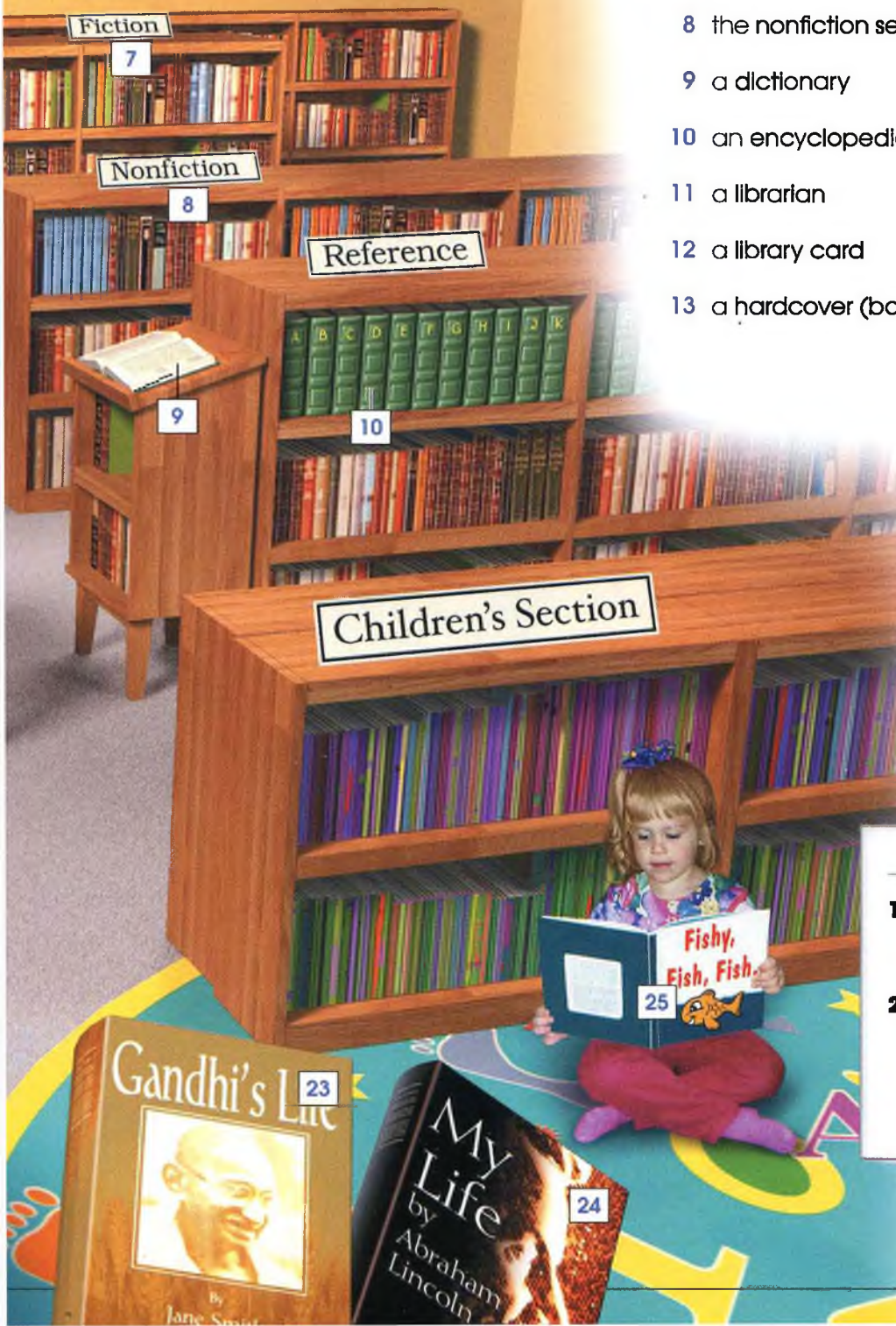

- 1 the periodical section
- 2 a magazine
- 3 a microfilm machine
- 4 the reading room
- 5 the reference desk
- 6 an online catalog / a computerized catalog
- 7 the fiction section
- 8 the nonfiction section
- 9 a dictionary
- 10 an encyclopedia
- 11 a librarian
- 12 a library card
- 13 a hardcover (book)
- 14 a paperback (book)
- 15 an atlas
- 16 the circulation desk / the checkout desk
- 17 a newspaper
- 18 a headline
- 19 a title
- 20 a novel
- 21 an author / a writer
- 22 a cookbook
- 23 a biography
- 24 an autobiography
- 25 a picture book

Word Partnerships

a library	book
a good	book
a boring	writer
a detective	novel
a romance	
a science-fiction	
a historical	

Words in Action

1. Imagine you will spend an afternoon in this library. What will you do?
2. Discuss the following questions with a group:
 - What is your favorite book?
 - What is your favorite magazine?
 - What is your favorite newspaper?



Daycare Center

Words in Context

Parents should look for the following things at a **daycare center**:

- Are the children busy and happy?
- Do the **childcare workers** take good care of the children?
- Is there a special room for **newborns**?
- Are the **high chairs**, **potty chairs**, and **changing tables** clean?

Word Partnerships

a cute	baby
a newborn	
baby	food
a clean	diaper
a dirty	
change	a diaper
play with	toys
put away	
share	



31 a newborn



32 an infant / a baby



33 a toddler



34 a preschooler



- | | | | |
|-------------------|------------------|-----------------------|--------------------------|
| 1 a nipple | 8 a parent | 16 a bib | 24 (baby) wipes |
| 2 a bottle | 9 a baby carrier | 17 a childcare worker | 25 a pacifier |
| 3 a crib | 10 a rattle | 18 a high chair | 26 a changing table |
| 4 a playpen | 11 a stroller | 19 formula | 27 a (disposable) diaper |
| 5 a rest mat | 12 a cubby | 20 a potty chair | 28 training pants |
| 6 a baby swing | 13 a girl | 21 a diaper pail | 29 a (cloth) diaper |
| 7 a teething ring | 14 a boy | 22 (baby) powder | 30 a diaper pin |
| | 15 toys | 23 (baby) lotion | |



Words in Action

- Which are the 10 most important items for a newborn? Discuss and make a list with a group.
- Imagine you have a one-year-old baby. You are taking a trip on an airplane. Which items will you take?



City Square

Words in Context

Prague and Marrakesh have interesting **city squares**. The squares have outdoor **cafés**, **street vendors**, **street musicians**, and **pedestrians**. There are many **hotels**, **museums**, and **restaurants**. At night, there are plenty of **tourists** in the squares.

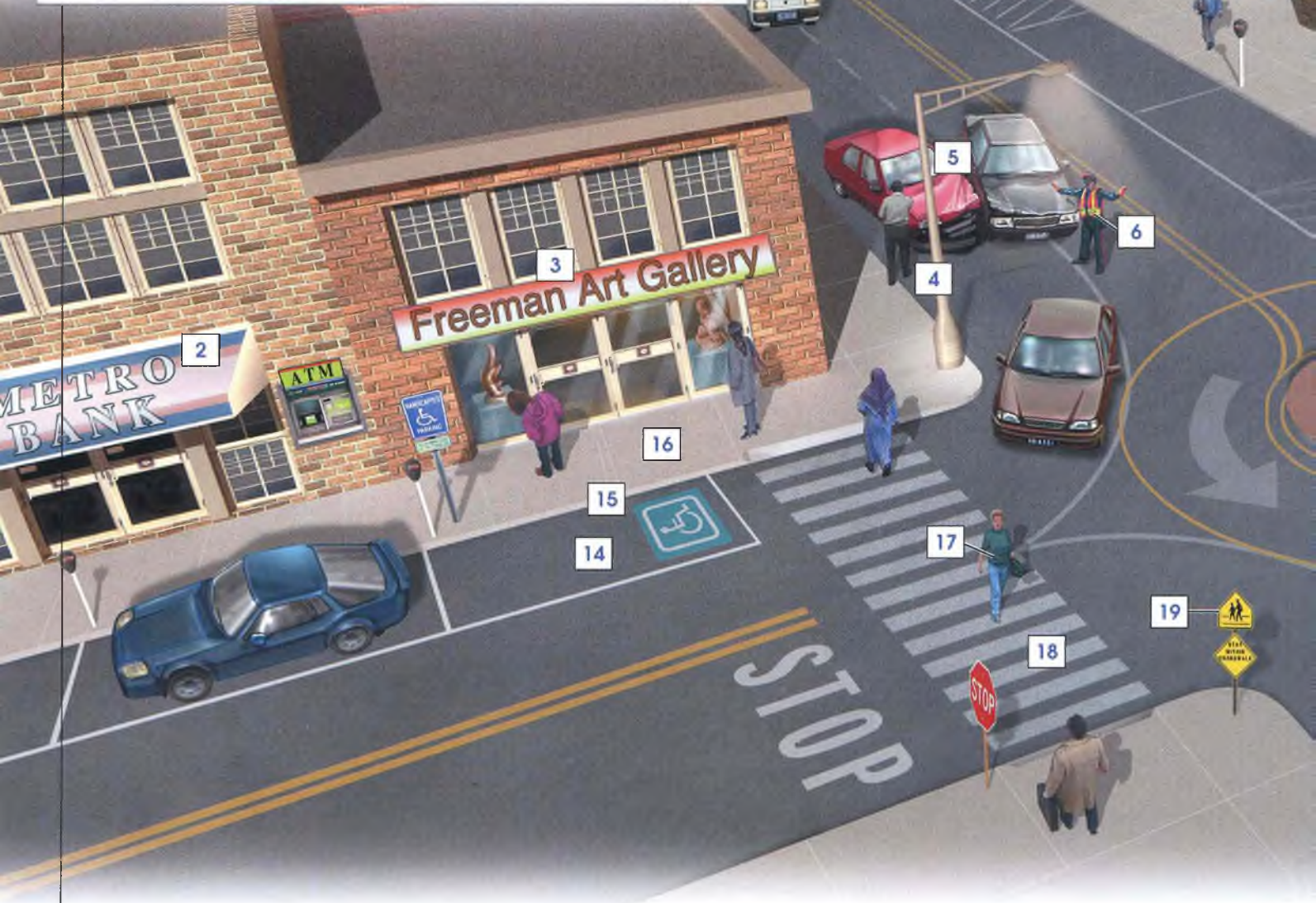

- | | | | |
|----------------------|-------------------|--------------------------------|----------------------|
| 1 a hotel | 6 a (traffic) cop | 11 a (fire) hydrant | 16 a sidewalk |
| 2 a bank | 7 a fountain | 12 a street vendor | 17 a pedestrian |
| 3 an art gallery | 8 a café | 13 a travel agency | 18 a crosswalk |
| 4 a streetlight | 9 a billboard | 14 a handicapped parking space | 19 a sign |
| 5 a traffic accident | 10 a monument | 15 a curb | 20 a (parking) meter |



- 21 a tourist information booth
- 22 a street musician
- 23 a statue
- 24 a museum
- 25 a newsstand

Word Partnerships

- | | |
|-------------------|--------|
| an art | museum |
| a science | |
| a natural history | |
| ----- | |
| a street | sign |
| a neon | |
| ----- | |
| a sidewalk | café |
| an outdoor | |

Words in Action

1. Imagine you are a tourist in this city square. Where will you go? What will you do?
2. Think about the town or city you live in or near. Make a list of all the things you can find there.



Crime and Justice

Words in Context

Iceland has very little **crime**. There are only four **prisons**, and many of the **prisoners** are part-time! There are usually only one or two **murders** a year, and crimes like **armed robbery** are extremely rare. There are sometimes **muggings** in the capital city of Reykjavík, but Iceland is still one of the safest countries in the world.





- 1 auto theft
- 2 bribery
- 3 burglary
- 4 theft
- 5 drug dealing
- 6 drunk driving
- 7 arson
- 8 graffiti
- 9 mugging
- 10 murder
- 11 shoplifting
- 12 vandalism
- 13 gang violence
- 14 armed robbery
- 15 an arrest
- 16 a victim
- 17 a witness

- 18 a criminal
- 19 handcuffs
- 20 a police officer
- 21 a trial
- 22 a jury
- 23 a judge
- 24 a lawyer / an attorney
- 25 a courtroom
- 26 a jail / a prison
- 27 a prisoner

Word Partnerships

a fair	trial
a speedy	
commit	a crime
witness	
report	
go to	prison
spend time in	
get out of	

Words in Action

1. Talk with a group. Which crimes are most common in your community?
2. Put the crimes in a list from the least serious crime to the most serious crime. Discuss your list with a partner.



Types of Homes

Words in Context

Do you live in a **house**, an **apartment**, or a **condo**? There are many other kinds of homes, too. For example, some people in the Sahara Desert live in **tents**. Some people in the U.S. live in **mobile homes**. And some people near the North Pole live in **igloos**.



live in a house
an apartment
a dorm

live on a houseboat
a ranch



- 1 a house
- 2 a tent
- 3 a cottage
- 4 a (log) cabin
- 5 a chalet
- 6 a duplex / a two-family house
- 7 a mobile home
- 8 a farmhouse
- 9 an apartment
- 10 a condominium / a condo
- 11 a villa
- 12 a townhouse
- 13 a houseboat
- 14 a palace
- 15 an igloo
- 16 a ranch
- 17 a retirement home
- 18 a dormitory / a dorm
- 19 a castle



20 the city / an urban area



21 the suburbs



22 a small town



23 the country / a rural area



Words in Action

1. What kinds of homes have you lived in or stayed in? Tell your class.
2. You can stay in three of these homes. Which three will you choose? Why?



Finding a Place to Live

Words in Context

Are you **looking for** an apartment? It isn't always easy. Read the classified ads in newspapers and talk to your friends. **Make** appointments to see a lot of apartments. Before you **sign** a lease, talk to the landlord.

Ask questions like these:

- How much is the security deposit?
- When is the rent due?
- When can I **move in**?

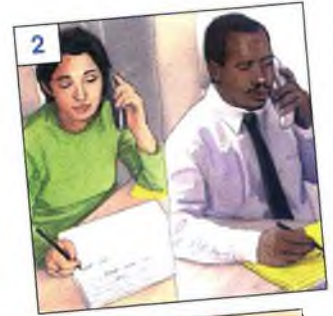

Renting an Apartment

- 1 **look for** an apartment
- 2 **make** an appointment (with the landlord)
- 3 **meet** the landlord
- 4 **see** the apartment
- 5 **ask** questions
- 6 **sign** the lease
- 7 **pay** a security deposit
- 8 **get** the key
- 9 **pack**
- 10 **load** a van or truck
- 11 **unpack**
- 12 **arrange** the furniture
- 13 **decorate** the apartment
- 14 **pay** the rent
- 15 **meet** the neighbors



Buying a House

- 16 call a realtor
- 17 look at houses
- 18 make a decision
- 19 make an offer
- 20 negotiate the price
- 21 inspect the house
- 22 apply for a loan
- 23 make a down payment
- 24 sign the loan documents
- 25 move in
- 26 make the (house) payment

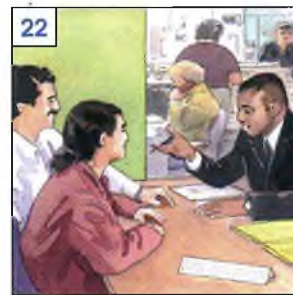
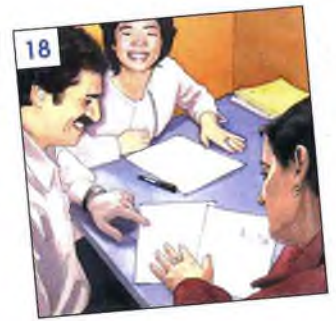

Word Partnerships

look for	an apartment	In the classified ads online with a realtor
pay	the rent	early late on time

Words in Action

1. Work in pairs. Cover the words. Say what's happening in one of the pictures. Your partner will find and point to this picture. Take turns.
2. Have you rented an apartment or bought a house? Tell your group what steps you took.



Apartment Building

Words in Context

I'm the **superintendent** of an **apartment building** in Los Angeles. We have 30 **unfurnished apartments**. Most of these are **studios**. We have a **laundry room** in the **basement**. There's **no doorman**, but I watch everyone who comes in the **lobby**. I take good care of my building.



- 1 a storage space
- 2 a dumpster
- 3 a superintendent / a super
- 4 stairs
- 5 a furnace
- 6 a water heater
- 7 a basement
- 8 a parking space
- 9 a studio (apartment)
- 10 a tenant
- 11 a roommate
- 12 a hallway
- 13 a one-bedroom apartment
- 14 an air conditioner
- 15 a workout room / a gym
- 16 a balcony
- 17 a courtyard
- 18 a laundry room
- 19 a fire escape
- 20 an unfurnished apartment
- 21 a furnished apartment
- 22 a lobby
- 23 an elevator
- 24 a revolving door
- 25 a doorman
- 26 a peephole
- 27 a door chain
- 28 a dead-bolt (lock)
- 29 a doorknob
- 30 an intercom
- 31 a key



Word Partnerships

the ground	floor
the first	
the second	
the third	
the fourth	

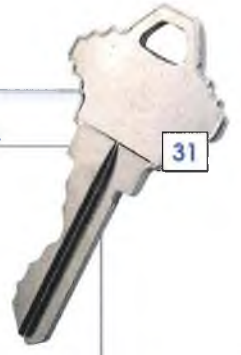

Words in Action

1. Role-play with a partner. One of you is the super of this building. The other is looking for an apartment.
 - Student A: *Is there a laundry room?*
 - Student B: *Yes. It's in the basement.*
2. Describe an apartment building you know.



House and Garden

Words in Context

Different cultures have different kinds of **houses**. North American houses often have **yards** with **lawns**. People cook on their **grills** and relax on a **patio**, **porch**, or **deck**. Some Arab and Mexican houses have courtyards. Even **windows** are different from place to place. In France, windows open like **doors**. In Greece and North Africa, windows are painted blue.

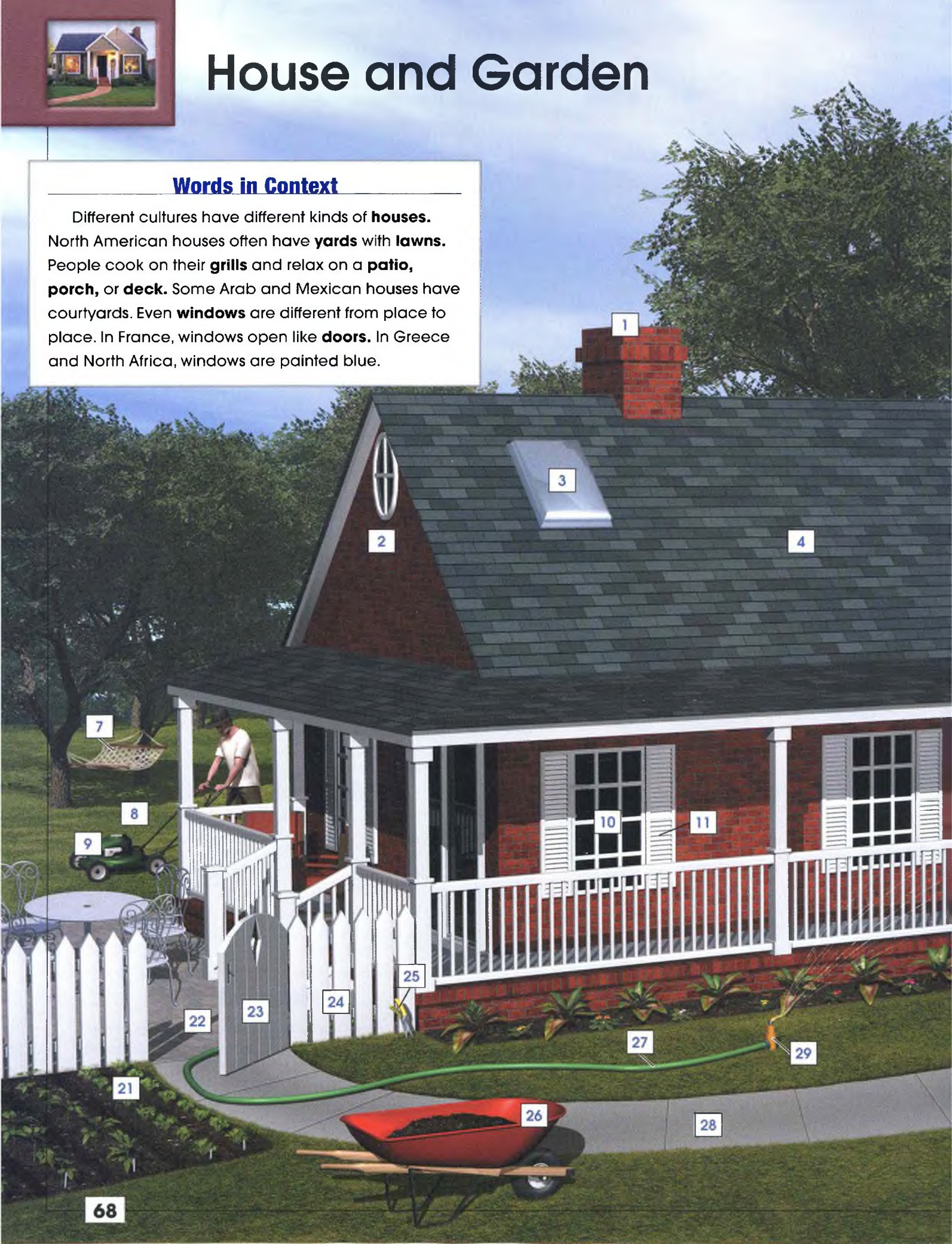

1

2

3

4

7

8

9

10

11

25

22

23

24

27

29

21

26

28

68

- 1 a chimney
- 2 an attic
- 3 a skylight
- 4 a roof
- 5 a deck
- 6 a grill / a barbecue
- 7 a hammock
- 8 a lawn / grass
- 9 a lawn mower
- 10 a window
- 11 a shutter
- 12 a door
- 13 a doorbell
- 14 a porch
- 15 steps
- 16 a garage
- 17 a rake
- 18 a driveway
- 19 a garbage can / a trash can
- 20 a yard
- 21 a garden
- 22 a patio
- 23 a gate
- 24 a fence
- 25 hedge clippers
- 26 a wheelbarrow
- 27 a (garden) hose
- 28 a walk(way)
- 29 a sprinkler



Word Partnerships

- | | |
|---------------|--------|
| a flower | garden |
| a vegetable | |
| a chain-link | fence |
| a picket | |
| a barbed wire | |
| a front | door |
| a screen | |
| a garage | |

Words in Action

1. Cover the word list. Name as many parts of the house as you can. Start at the top of the house and work your way down.
2. Draw your dream house. Label all the parts. Show your dream house to a partner. How are they similar? How are they different?



Kitchen and Dining Area

Words in Context

Before 1900, few **kitchens** had electricity. People used **candles** for light. There were no **refrigerators**, no **ovens**, no **dishwashers**, and no **blenders**. There were no faucets, either. To wash **dishes**, people had to get water from outdoors and heat it over a fire.

- | | |
|--------------------------------|---------------|
| 1 a microwave (oven) | 21 a stool |
| 2 a cabinet | 22 a chair |
| 3 dishes | 23 a plate |
| 4 a shelf | 24 a bowl |
| 5 a counter(top) | 25 a glass |
| 6 a stove | 26 a placemat |
| 7 a (tea) kettle | 27 silverware |
| 8 an oven | 28 a candle |
| 9 a potholder | 29 a teapot |
| 10 a coffeemaker | 30 a mug |
| 11 a spice rack | 31 a napkin |
| 12 a blender | 32 a table |
| 13 a toaster | |
| 14 a dishwasher | |
| 15 a sink | |
| 16 a drying rack / a dish rack | |
| 17 a garbage disposal | |
| 18 a dish towel | |
| 19 a freezer | |
| 20 a refrigerator | |

Word Partnerships

a dining room	table
a kitchen	chair
an electric	stove
a gas	
load	the dishwasher
start / turn on	
empty	





2

3

4

11

12

13

15

16

18

19

20

14

17

28

29

30

23

24

25

22

27

26

32

31

Words in Action

1. What do you think are the ten most important things in this kitchen? Why?
2. Work with a group. What things do all of you have in your kitchen? Make a list.



Living Room

Words in Context

Some people like lots of furniture in their living rooms—a **sofa**, a **love seat**, a **coffee table**, chairs, a **wall unit**, and several **lamps**. Others like just a rug and a couple of **easy chairs**. In the Middle East, people often sit on **cushions** or low **benches** instead of chairs. And in some Asian countries, people sit on the **floor**.



- | | | | |
|----------------------------------|--------------------|---------------------|--------------------|
| 1 a bench | 9 a (throw) pillow | 17 a ceiling | 25 a thermostat |
| 2 a cushion | 10 a window seat | 18 a smoke detector | 26 a mantel |
| 3 an armchair /
an easy chair | 11 a love seat | 19 blinds | 27 a fireplace |
| 4 an end table | 12 a coffee table | 20 a curtain | 28 a fire screen |
| 5 a lamp | 13 an ottoman | 21 a wall | 29 a house plant |
| 6 a lampshade | 14 the floor | 22 a bookcase | 30 a fire |
| 7 a wall unit | 15 a curtain rod | 23 a vent | 31 a rocking chair |
| 8 a sofa / a couch | 16 a (ceiling) fan | 24 a (light) switch | 32 an outlet |

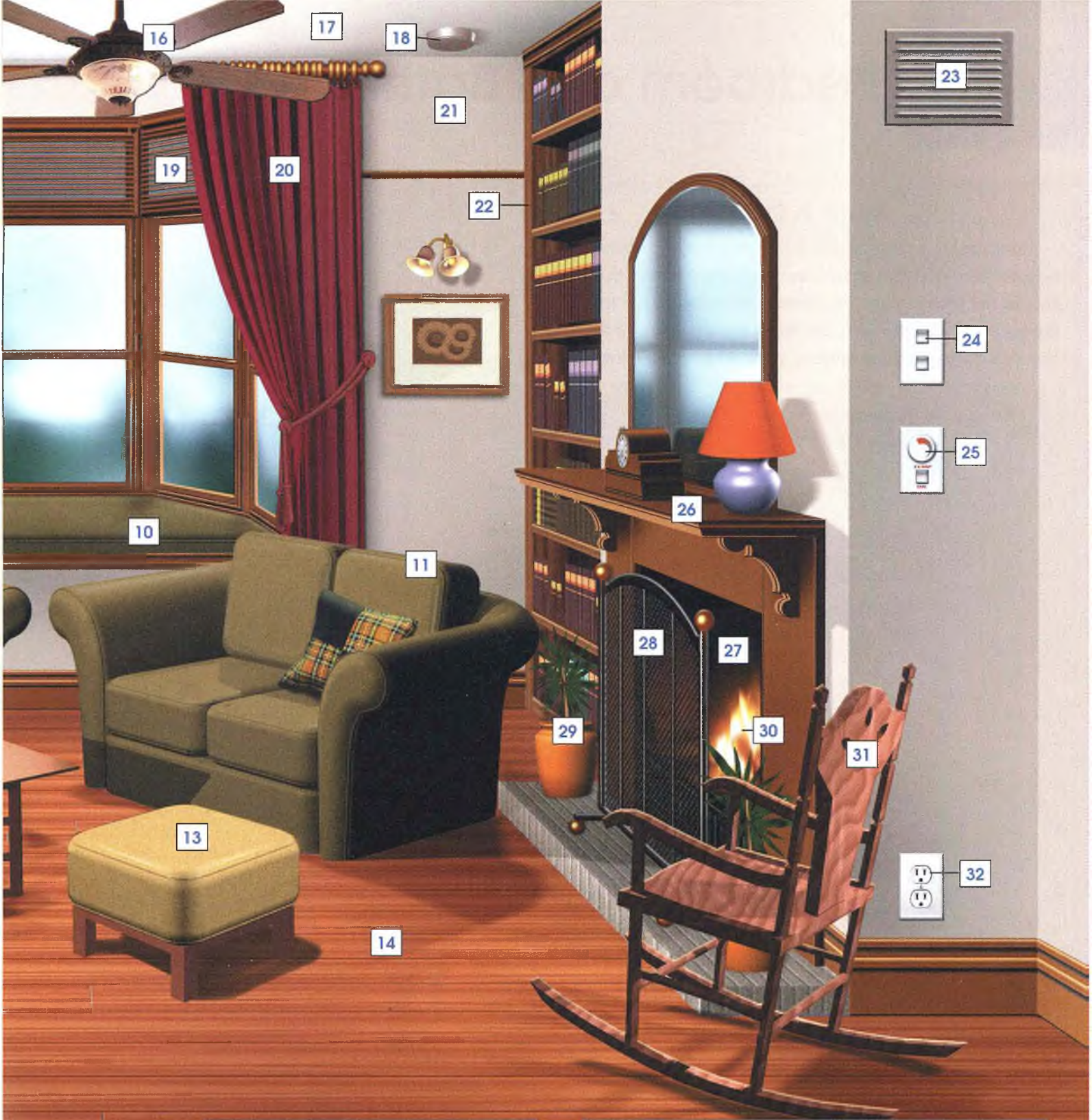

Word Partnerships

- | | |
|---------|--------------------|
| a floor | lamp |
| a table | |
| a desk | |
| <hr/> | |
| sit | in an armchair |
| | in a rocking chair |
| | on a sofa |
| | on the floor |
| | on a cushion |

Words in Action

- How is your living room similar to this one? How is it different? Discuss with a partner.
 - *I have a fireplace like the one in the picture.*
 - *My sofa is bigger than the one in the picture.*
- Draw your perfect living room. Label all the items in the drawing.



Bedroom and Bathroom

Words in Context

Feng shui is a Chinese art. It suggests ways to make homes healthy and happy. For a calm **bedroom**, your **bed** should not face a door. Your **bedspread** should not touch the floor. In the **bathroom**, the **toilet** should not face the door. You should have many **mirrors**. Mirrors bring happiness.



1 a closet

2 a blanket

3 a carpet

4 a rug

5 a drawer

6 a dresser

7 a mirror

8 a (window) shade

9 an alarm clock

10 a night table

11 a pillowcase

12 a pillow

13 a mattress

14 a bed

15 a sheet

16 a comforter

17 a bedspread

18 a shower

19 a shower curtain

20 a drain

21 a medicine cabinet

22 a (bath)tub

23 a plunger

24 toilet paper /
toilet tissue

25 a toilet

26 a towel

27 a faucet

28 a sink

29 a washcloth

30 a toilet brush

31 a wastebasket



Word Partnerships

a twin bed

a double

a queen-size

a king-size

a bunk

a fitted sheet

a flat

flush the toilet

go to bed

get out of

make the

Words in Action

1. Draw your bedroom and label the things in it. Then describe it to a partner.
 - *There is a big bed with three red pillows. There's also a dresser with five drawers.*
2. What things are usually already in a bedroom and bathroom when you move into a house or apartment? What things do you usually need to bring? Make lists with a partner.



Household Problems

Words in Context

A: Our kitchen sink is **clogged**.

B: Call a **plumber** right away.

A: And the power is **out**.

B: Call an **electrician**.

A: And the roof is **leaking**, too.

B: Call a real estate agent. You need a new house!



4



5

6

17



7

8

9



23 ants



24 mice



25 rats



26 termites



27 cockroaches

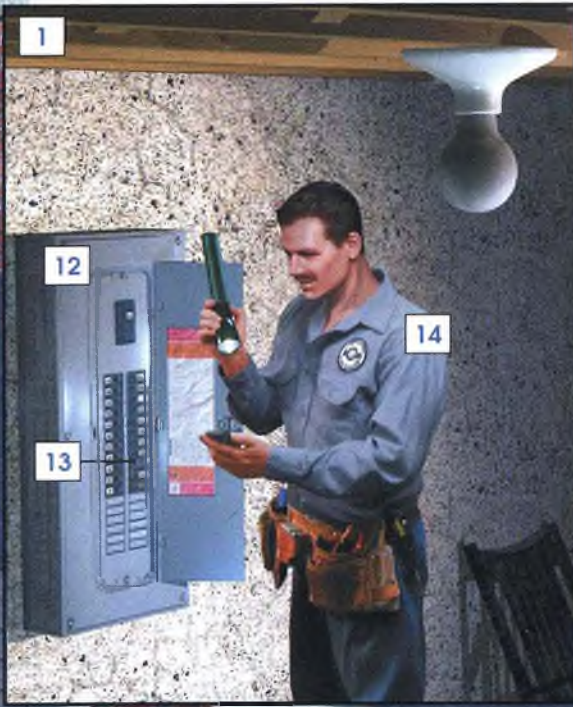

- 1 The power is out.
- 2 The toilet is clogged.
- 3 The roof leaks.
- 4 The wall is cracked.
- 5 The faucet drips.
- 6 The lightbulb is burned out.
- 7 The heater doesn't work.
- 8 The pipes are frozen.
- 9 The basement is flooded.
- 10 The window is broken.
- 11 The lock is jammed.
- 12 a breaker panel
- 13 a circuit breaker
- 14 an electrician
- 15 a plumber
- 16 a roofer
- 17 a handyman
- 18 an exterminator
- 19 a water meter
- 20 a gas meter
- 21 a meter reader
- 22 a locksmith

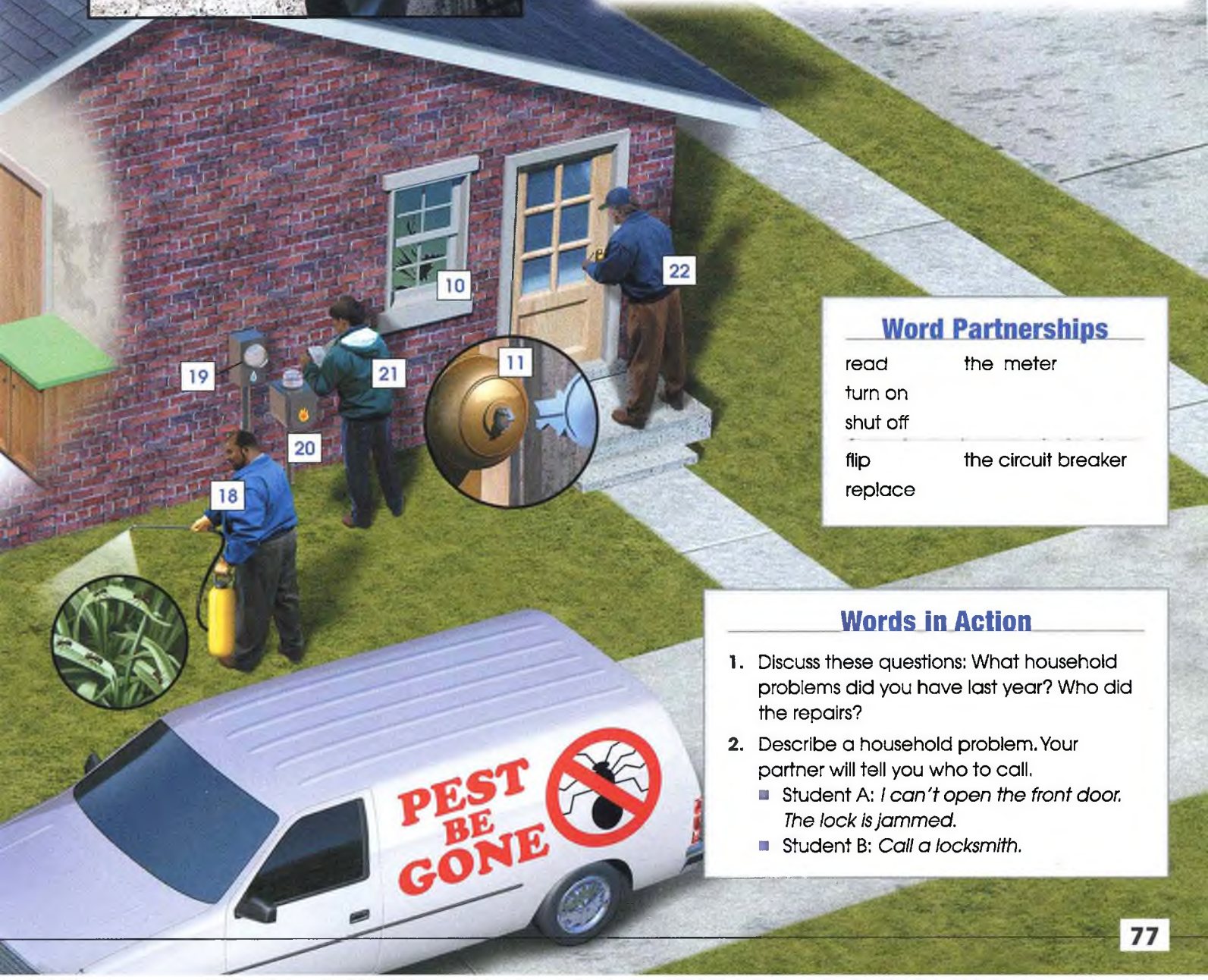

Word Partnerships

read	the meter
turn on	
shut off	
flip	the circuit breaker
replace	

Words in Action

1. Discuss these questions: What household problems did you have last year? Who did the repairs?
2. Describe a household problem. Your partner will tell you who to call.
 - Student A: *I can't open the front door. The lock is jammed.*
 - Student B: *Call a locksmith.*



Household Chores

Words in Context

In many houses, men and women share **household chores**. For example, in some houses women **do** the cooking, and men **wash** the dishes. Sometimes women **do** the laundry, and men **fold** the clothes. Sometimes women **weed** the garden, and men **rake** the leaves. What chores do you do in your family?



- 1 make the bed
- 2 change the sheets
- 3 do the laundry
- 4 sweep the floor
- 5 fold the clothes
- 6 pay the bills

- 7 vacuum the carpet
- 8 dust
- 9 polish the furniture
- 10 clean the sink
- 11 scrub the toilet
- 12 mop the floor
- 13 empty the wastebasket
- 14 shake out the rug

- 15 weed the garden
- 16 wash the car
- 17 mow the lawn /
mow the grass
- 18 water the lawn
- 19 take out the trash /
put out the trash
- 20 rake the leaves
- 21 do the dishes /
wash the dishes
- 22 cook / do the cooking
- 23 dry the dishes
- 24 put away the dishes



Word Partnerships

clean	the house
	the bathroom
	your bedroom
polish	the car
	the silver
	the floor

Words in Action

1. Name two household chores you like to do and two you hate to do.
2. Work in a group. Imagine your group is a family—a mother, a father, and teenage children. Divide the household chores on the list among yourselves. Who will do what?



Cleaning Supplies

Words in Context

Do you want to wash a window? Follow these steps:

- Put on **rubber gloves**.
- Mix a gallon of warm water with a little ammonia.
- Put the liquid on the window with a clean **sponge**.
- Pull a **squeegee** across the window.
- Wipe the squeegee with a **rag** or a **paper towel** and repeat.

- | | |
|-----------------------------------|--------------------|
| 1 a feather duster | 17 a rag |
| 2 a dustpan | 18 rubber gloves |
| 3 a vacuum cleaner bag | 19 cleanser |
| 4 vacuum cleaner attachments | 20 a scrub brush |
| 5 a vacuum (cleaner) | 21 a sponge |
| 6 a squeegee | 22 a flyswatter |
| 7 paper towels | 23 a stepladder |
| 8 trash bags | 24 a mousetrap |
| 9 furniture polish | 25 a recycling bin |
| 10 a dust cloth | 26 a mop |
| 11 glass cleaner | 27 a dust mop |
| 12 dishwasher detergent | 28 a broom |
| 13 dish soap / dishwashing liquid | |
| 14 a scouring pad | |
| 15 bug spray / insect spray | |
| 16 a bucket / a pail | |

Word Partnerships

heavy-duty	trash bags
20-gallon	
plastic	
a sponge	mop
a string	
a floor	
a push	broom
a kitchen	





Words in Action

1. Name cleaning supplies you use often. What do you use each item for?
2. You need to clean your living room, your bathroom, and your kitchen. Which cleaning items will you use for each room?



Fruits and Nuts

Words in Context

Grapes are one of the most popular **fruits** in the world. Every day, millions of people enjoy them. Many people also like **apples**. Apples first came from Afghanistan. **Oranges, lemons, and limes** are also popular around the world. These fruits came from China.

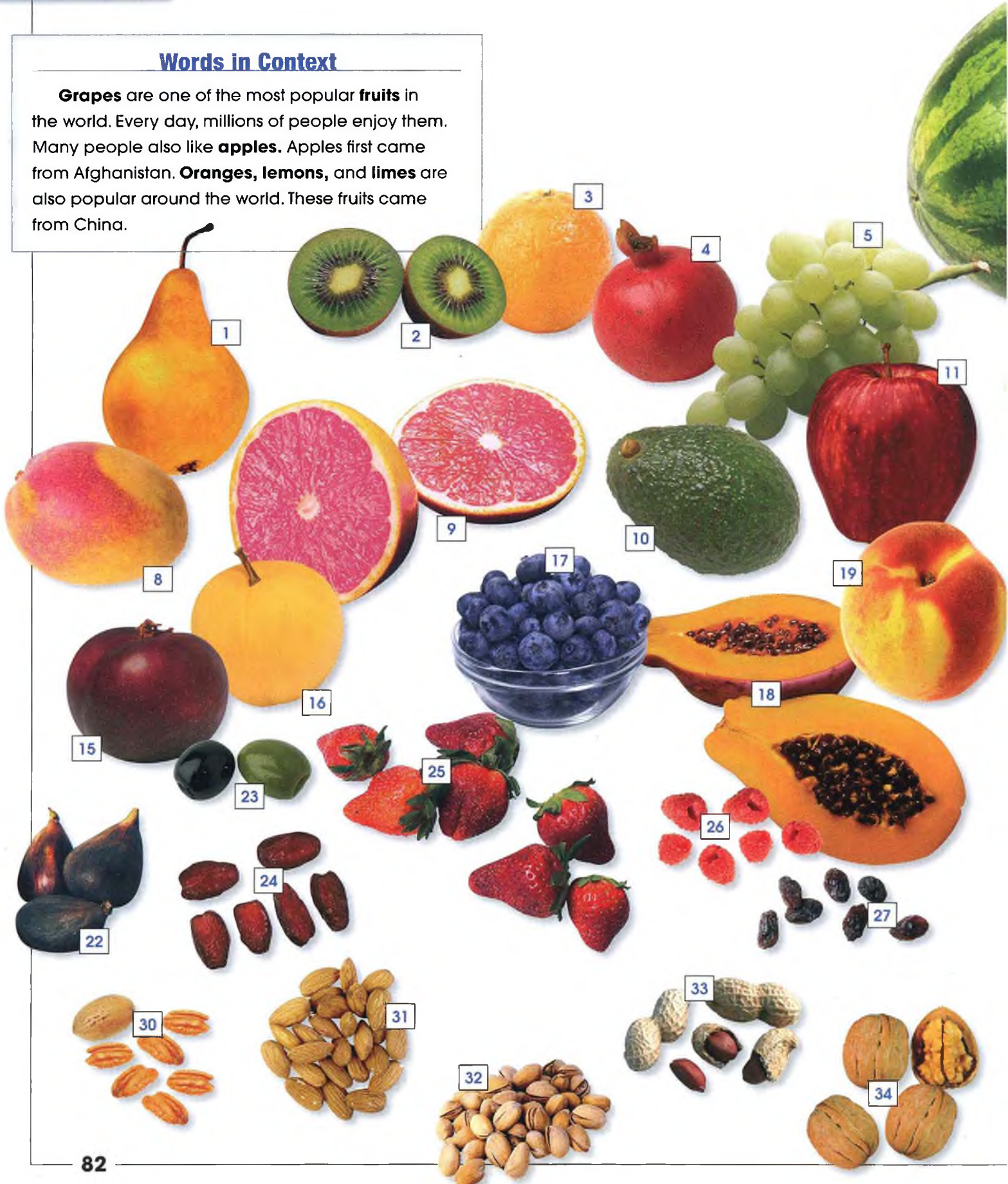

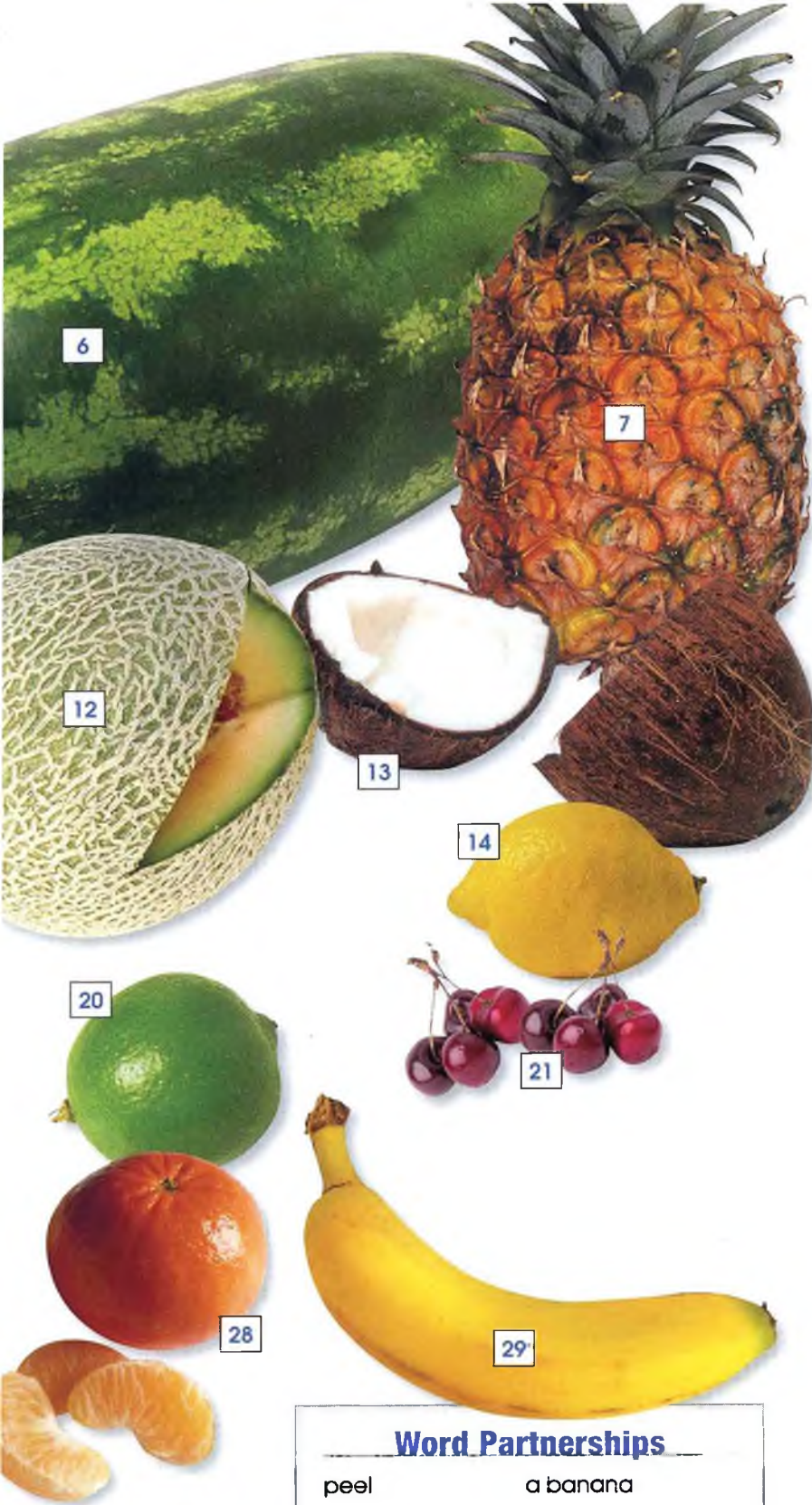

Fruits

- 1 a pear
- 2 a kiwi
- 3 an orange
- 4 a pomegranate
- 5 grapes
- 6 a watermelon
- 7 a pineapple
- 8 a mango
- 9 a grapefruit
- 10 an avocado
- 11 an apple
- 12 a cantaloupe
- 13 a coconut
- 14 a lemon
- 15 a plum
- 16 an apricot
- 17 blueberries
- 18 a papaya

- 19 a peach
- 20 a lime
- 21 cherries
- 22 figs
- 23 olives
- 24 dates
- 25 strawberries
- 26 raspberries
- 27 raisins
- 28 a tangerine
- 29 a banana

Nuts

- 30 pecans
- 31 almonds
- 32 pistachios
- 33 peanuts
- 34 walnuts

Word Partnerships

peel	a banana an orange an apple
crack (open)	a nut
ripe	fruit
juicy	
canned	
dried	
citrus	
tropical	

Words in Action

1. What are your five favorite fruits? Rank them in order. Share your list with your class. Is your list similar to other students' lists?
2. Create a recipe for a delicious fruit drink. Use at least four fruits.



Vegetables

Words in Context

Cabbage Slaw Recipe

Cut a head of **cabbage** into thin slices. Then cut a large **cucumber**, a **bell pepper**, a **carrot**, and an **onion** (or three **scallions**) into small pieces. Mix everything together with a little salt. Add a little oil and vinegar and mix everything again.



- 1 broccoli
- 2 beets
- 3 asparagus
- 4 spinach
- 5 lettuce
- 6 squash
- 7 a tomato
- 8 cabbage
- 9 pinto beans
- 10 chickpeas / garbanzo beans
- 11 a zucchini
- 12 an eggplant
- 13 an artichoke
- 14 celery
- 15 an onion
- 16 cauliflower
- 17 a turnip
- 18 kidney beans
- 19 a carrot
- 20 bean sprouts
- 21 lima beans
- 22 a sweet potato
- 23 a bell pepper
- 24 corn
- 25 a cucumber
- 26 a potato

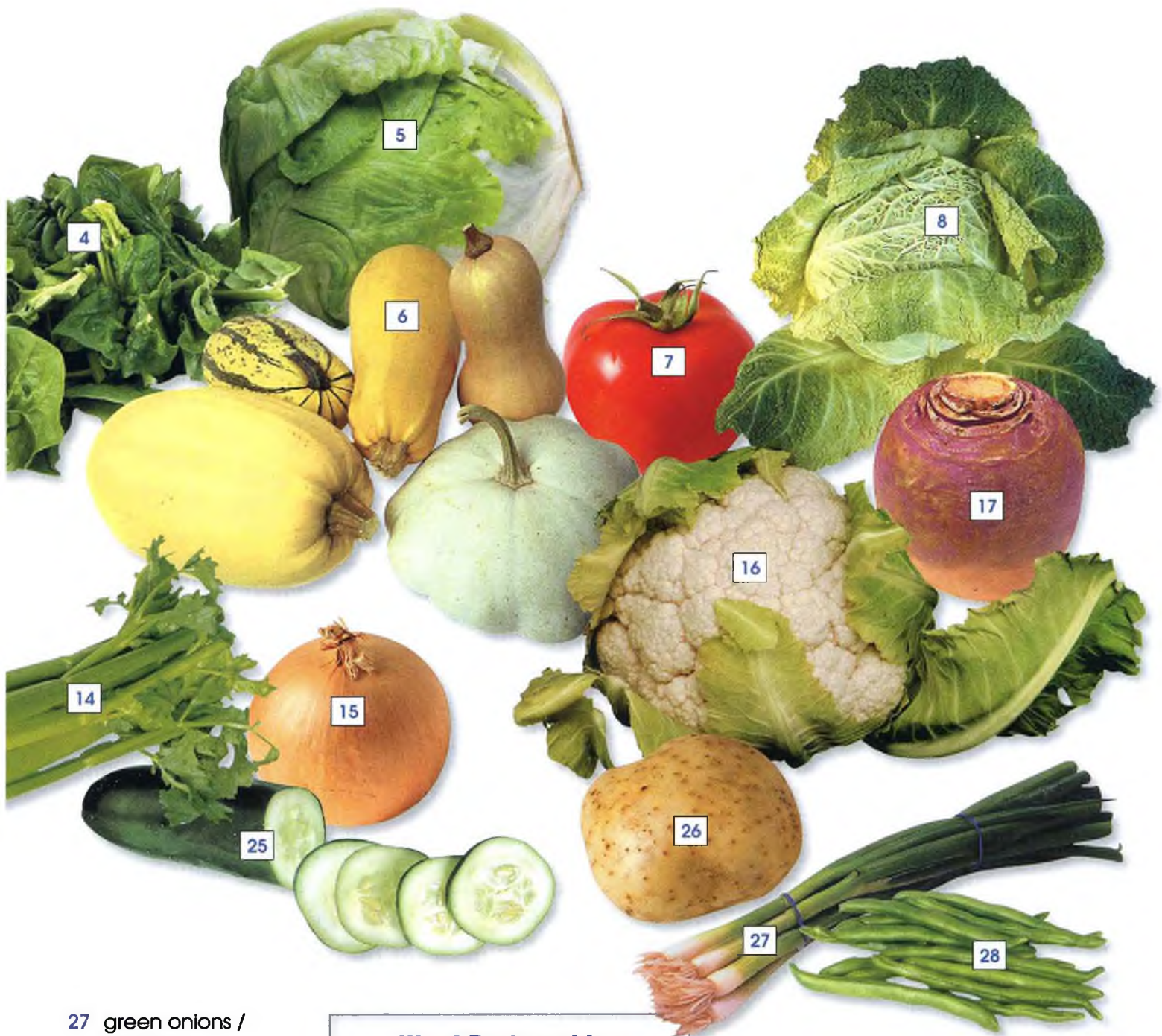

- 27 green onions / scallions
- 28 green beans / string beans
- 29 garlic
- 30 peas
- 31 a radish
- 32 mushroom

Word Partnerships

a head of	cabbage
	cauliflower
	lettuce
an ear of	corn
a spinach	leaf
a lettuce	
fresh	vegetables
frozen	
raw	
organic	

Words in Action

1. Which vegetables do you have in your house right now? Which ones do you eat raw? Which ones have you never eaten?
2. Make two lists: *Vegetables I like* and *Vegetables I don't like*. Compare your lists with a partner.



Meat, Poultry, and Seafood

Words in Context

Fish and **shellfish** are healthy foods. They contain very little fat. The Koreans and the Japanese eat a lot of **seafood**. **Clams**, **oysters**, **shrimp**, and **tuna** are favorite foods in these countries. However, Americans love **meat**. The average American eats 27 pounds (12.3 kilograms) of **ground beef** a year—mostly in hamburgers.

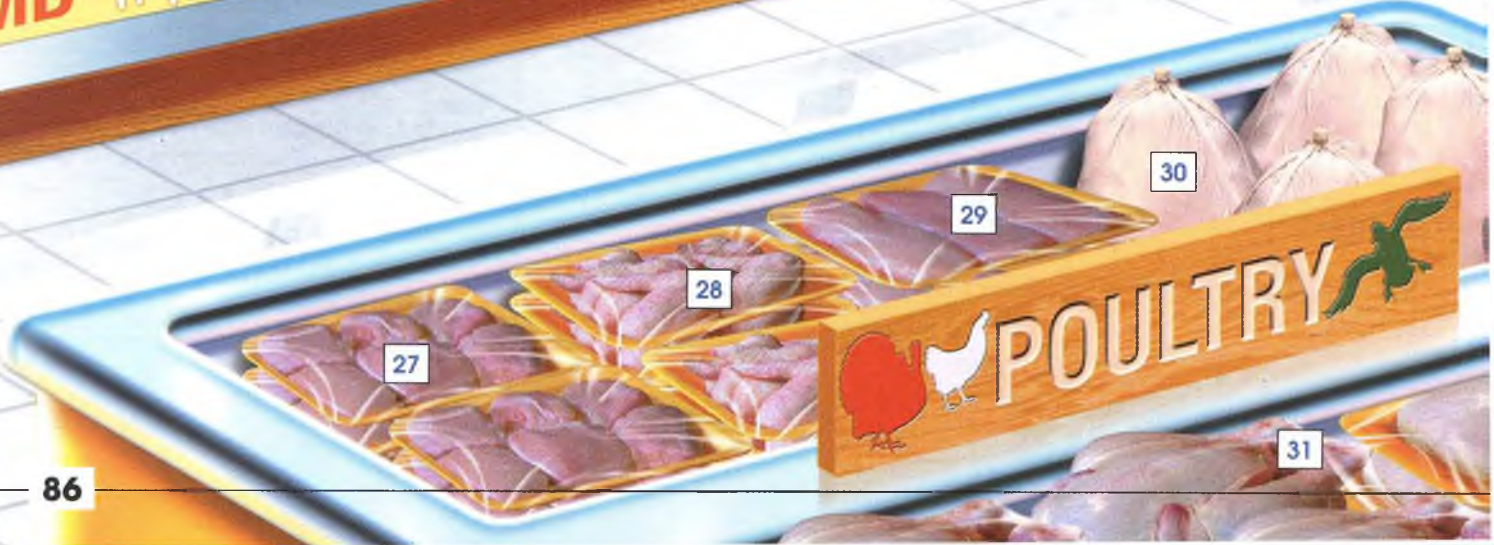

SEAFOOD

- | | | |
|---------------|------------------|----------------------|
| 1 lamb chops | 11 roast beef | 22 cod |
| 2 leg of lamb | 12 liver | 23 swordfish |
| 3 pork chops | 13 veal cutlets | 24 salmon |
| 4 ham | 14 lobster | 25 trout |
| 5 salami | 15 oysters | 26 tuna |
| 6 sausages | 16 clams | 27 thighs |
| 7 pork roast | 17 mussels | 28 wings |
| 8 ground beef | 18 crab | 29 breasts |
| 9 ribs | 19 scallops | 30 turkey |
| 10 steak | 20 shrimp | 31 chicken |
| | 21 filet of sole | 32 duck |
| | | 33 drumsticks / legs |



Word Partnerships

raw	fish
fresh	
frozen	
grilled	
fatty	meat
lean	
a rare	steak
a medium	
a well-done	

Words in Action

1. Pick your favorite items from the meat, poultry, and seafood sections. Compare your favorites with a partner.
2. Imagine you are having a barbecue. What meat, poultry, and seafood will you buy?

32

33



Inside the Refrigerator

Words in Context

Do you want a well-organized **refrigerator**? Here are some suggestions. Keep fruit and vegetables in the drawers. Put **milk**, **apple juice**, and **orange juice** in the door rack. **Eggs** are safe in the egg container in the door. Always keep raw meat, poultry, and fish on the bottom shelf. **Ice cream** and **frozen vegetables** stay frozen in the freezer.

- | | |
|---------------------|---------------------|
| 1 frozen vegetables | 18 salad |
| 2 frozen waffles | 19 (salad) dressing |
| 3 ice cream | 20 bacon |
| 4 ice tray | 21 cold cuts |
| 5 soda | 22 (cheddar) cheese |
| 6 margarine | 23 butter |
| 7 mayonnaise | 24 (Swiss) cheese |
| 8 sour cream | 25 eggs |
| 9 iced tea | 26 milk |
| 10 pickles | 27 orange juice |
| 11 tofu | 28 apple juice |
| 12 yogurt | |
| 13 syrup | |
| 14 cream | |
| 15 bottled water | |
| 16 cake | |
| 17 jam | |

Word Partnerships

fruit	salad
potato	
pasta	
scrambled	eggs
fried	
hard-boiled	
poached	
mozzarella	cheese
Parmesan	
cottage	



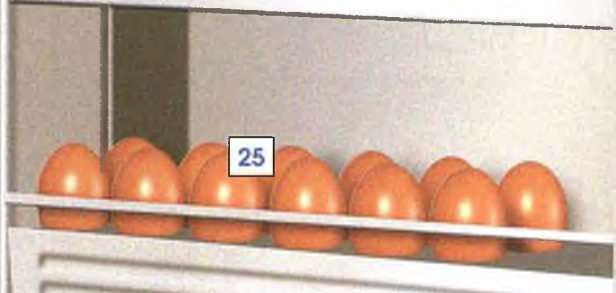
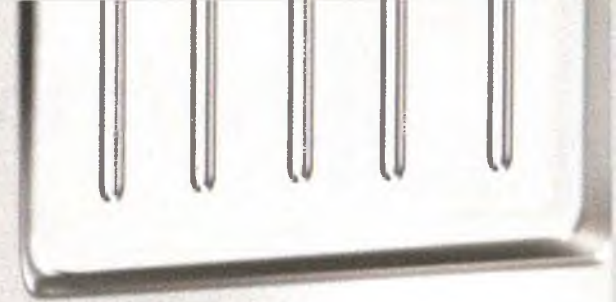

Words in Action

1. Think about the foods in the refrigerator. Make three lists: *Very healthy*, *Less healthy*, and *Not healthy*. Discuss your list with a partner.
2. Plan your dinner tonight using the food in this refrigerator.



Food to Go

Words in Context

Do you eat at the **food court**? Health experts have some advice for you. Don't order a **hot dog** and **french fries**. Order a salad instead. Don't have a **hamburger**. Have **beans** and **rice** instead. And finally, don't order **coffee** or soda. Have water or juice.

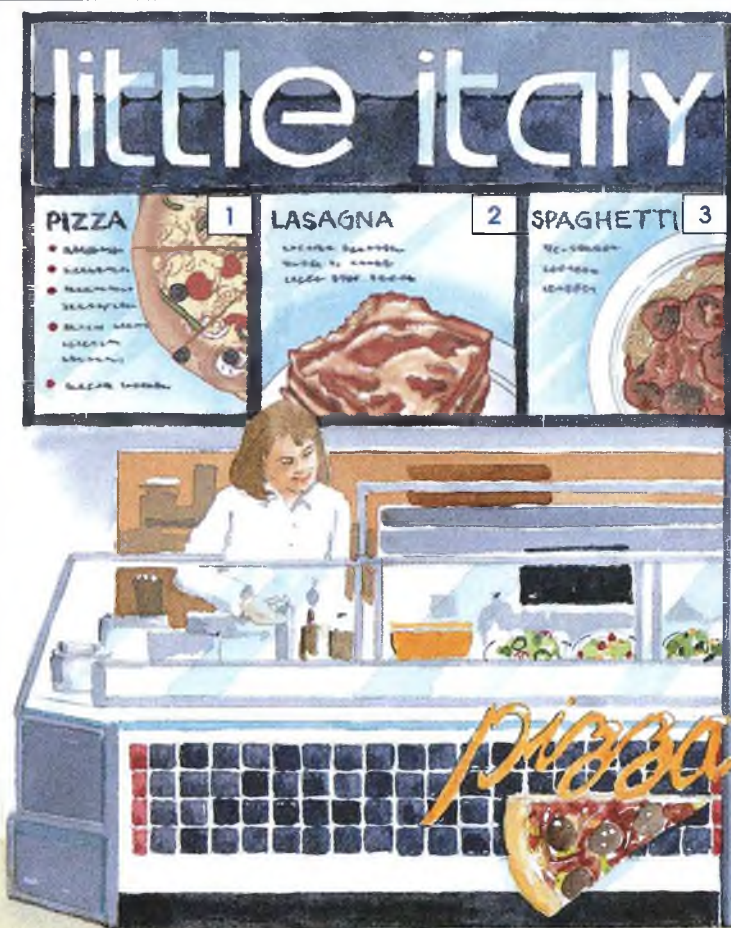

- 1 pizza
- 2 lasagna
- 3 spaghetti
- 4 a hamburger
- 5 a bagel
- 6 fish and chips

- 7 french fries
- 8 a hot dog
- 9 a baked potato
- 10 a sandwich
- 11 coffee
- 12 tea

- 13 a straw
- 14 a muffin
- 15 a doughnut
- 16 ketchup
- 17 mustard
- 18 chopsticks

Word Partnerships

sticky	rice
steamed	
fried	
black	beans
pinto	
refried	
a slice of	pizza
a piece of	
a small	
a medium	
a large	



- | | |
|--------------------------|---------------|
| 19 rice | 25 a burrito |
| 20 stir-fried vegetables | 26 a taco |
| 21 chicken teriyaki | 27 salsa |
| 22 an egg roll | 28 beans |
| 23 sushi | 29 a tortilla |
| 24 soy sauce | |

Words in Action

- Which take-out foods do you like? Which ones don't you like?
- Work with a partner. Role-play ordering food at one of the places in the picture.
 - Student A: *Can I help you?*
 - Student B: *Yes, I'd like two egg rolls.*
 - Student A: *Do you want something to drink?*
 - Student B: *Yes. Coffee, please.*



Cooking



Shish Kebab Recipe

- 1 Measure $\frac{1}{4}$ cup of olive oil.
- 2 Dice 1 tablespoon of garlic.
- 3 Whisk the oil and garlic with a little lemon juice.
- 4 Add 1 pound of lamb cubes.
- 5 Marinate overnight in the refrigerator.
- 6 Grill the kebabs for 5 minutes on each side.

Breakfast Burrito Recipe

- 7 Scramble 2 eggs in a bowl.
- 8 Fry the eggs.
- 9 Broil 2 slices of bacon.
- 10 Steam a cup of broccoli.
- 11 Grate $\frac{1}{4}$ cup of cheese.
- 12 Fold everything into a tortilla.
- 13 Microwave for 30 seconds.



Roast Chicken with Potatoes Recipe

- 14 Season the chicken with garlic and rosemary.
- 15 Roast at 350°F (175°C). (20 minutes per pound)
- 16 Baste frequently with pan juices.
- 17 Boil the potatoes.

° = degrees





Pea Soup Recipe

- 18 Slice 1 large onion.
- 19 Sauté the onion in oil.
- 20 Stir the onion and 1 pound of split peas into 2 quarts of water.
- 21 Simmer for 2 hours.
- 22 Peel 4 large carrots.
- 23 Chop the carrots and add to the soup.
- 24 Cook for 30 minutes more.
- 25 Puree the soup in a blender.

Candy Pecans Recipe

- 26 Grease a cookie sheet.
- 27 Beat 1 egg white.
- 28 Sift $\frac{1}{2}$ cup of sugar with 2 teaspoons of cinnamon.
- 29 Mix 3 cups of pecans and the sugar and cinnamon into the egg white.
- 30 Spread the mix on a cookie sheet.
- 31 Bake at 250°F (120°C).



Word Partnerships

- | | |
|-------|------------|
| bake | bread |
| | a cake |
| ----- | |
| steam | vegetables |
| chop | |
| cook | |
| ----- | |
| peel | potatoes |
| boil | |

Words in Action

1. Which recipe looks the best to you? Why?
2. Write down your favorite recipe. Put your recipe together with your classmates' recipes to make a class cookbook.



Cooking Equipment

Words in Context

Every country has its own **cooking equipment**. For example, Italian kitchens usually have a big **pot** for cooking pasta. Many Mexican kitchens have a special **pan** to make tortillas. Asian kitchens often have a **grill** for meat and a special **vegetable steamer**. Many kitchens around the world have a **set of knives**, a **cutting board**, **measuring cups**, and **measuring spoons**.

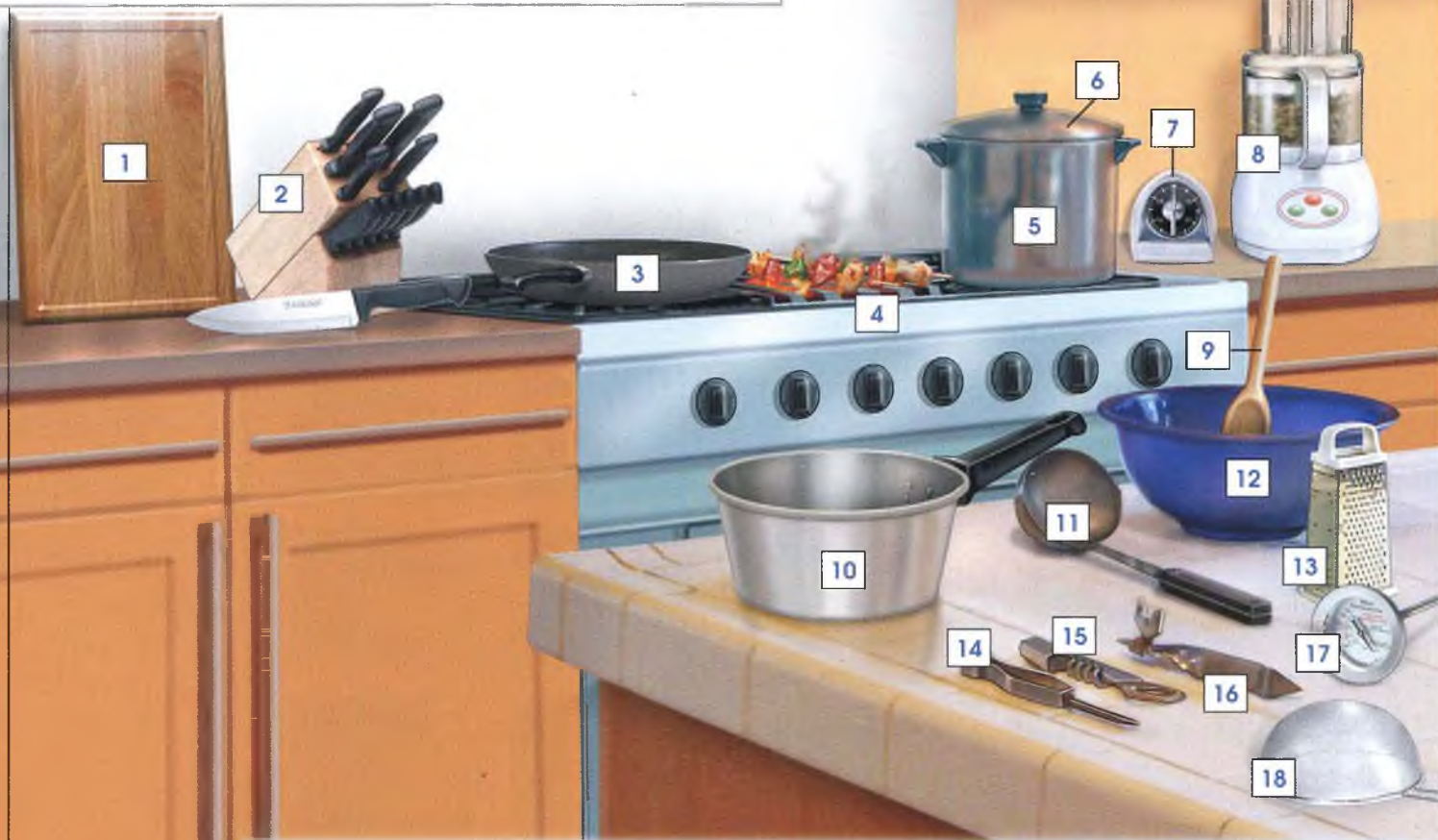

1 a cutting board

2 a set of knives

3 a (frying) pan

4 a grill

5 a pot

6 a lid

7 a (kitchen) timer

8 a food processor

9 a wooden spoon

10 a saucepan

11 a ladle

12 a mixing bowl

13 a grater

14 a vegetable peeler

15 a bottle opener

16 a can opener

17 a (meat) thermometer

18 a strainer



- 19 a (hand) mixer
- 20 a whisk
- 21 a cookie sheet
- 22 a rolling pin
- 23 measuring cups
- 24 measuring spoons
- 25 a casserole (dish)

- 26 a (vegetable) steamer
- 27 a colander
- 28 a wok
- 29 a pie pan
- 30 a cake pan
- 31 a spatula

Word Partnerships

a cast-iron	pan
an aluminum	pot
a stainless steel	
a bread	knife
a paring	
a carving	
a sharp	
a dull	

Words in Action

- Which five pieces of cooking equipment do you use most often? What do you use each piece for?
- What food do you like to cook? What cooking equipment do you need to make it?



Measurements and Containers

Words in Context

At a farmer's market, you can see a **pile** of ripe tomatoes, smell a warm **loaf** of bread, buy a **jar** of honey, and find a **bunch** of fresh carrots. You can meet the farmers who grow your food and vendors who sell **bars** of homemade soap and **bouquets** of fresh flowers.



Abbreviations

tsp.	=	teaspoon
TBS.	=	tablespoon
c.	=	cup
oz.	=	ounce
qt.	=	quart
pt.	=	pint
gal.	=	gallon
lb.	=	pound
g.	=	gram
kg.	=	kilogram
l.	=	liter



4 qt.	=	1 gal.
3 tsp.	=	1 TBS.
1 qt.	=	.94 l.
1 oz.	=	28 g.
1 lb.	=	.45 kg.

- | | | |
|-----------------------------|--------------------------|--------------------------|
| 1 a pint | 13 a cup of coffee | 25 a container of yogurt |
| 2 a cup | 14 a pitcher of lemonade | 26 a six-pack of soda |
| 3 an ounce | 15 a piece of cake | 27 a can of soda |
| 4 a teaspoon | 16 a loaf of bread | 28 a pile of tomatoes |
| 5 a tablespoon | 17 a liter of water | 29 a bunch of carrots |
| 6 a bouquet of flowers | 18 a quart of milk | 30 a crate of melons |
| 7 a bottle of olive oil | 19 a pound of cherries | 31 a basket of apples |
| 8 a bar of soap | 20 a box of strawberries | |
| 9 a tube of hand cream | 21 a gallon of cider | |
| 10 a carton of orange juice | 22 a bag of potatoes | |
| 11 a tray of pastries | 23 a carton of eggs | |
| 12 a pot of coffee | 24 a jar of honey | |



Word Partnerships

- | | |
|------------|---------|
| a can of | soup |
| | tuna |
| a box of | cereal |
| | pasta |
| | cookies |
| a cup of | tea |
| | sugar |
| | flour |
| a piece of | pie |
| | bread |

Words in Action

1. Imagine you are shopping at a farmer's market. What will you buy? Why?
2. Name five containers you have at home. Tell what is in each container.



Supermarket

Words in Context

The first **supermarket** opened in France in the early 1900s. Before that, people bought **groceries** like **produce**, **dairy products**, and **canned goods** in small shops and markets. Now there are supermarkets in every country of the world. Besides food, you can find **household cleaners**, **paper products**, and **pet food** in most supermarkets.

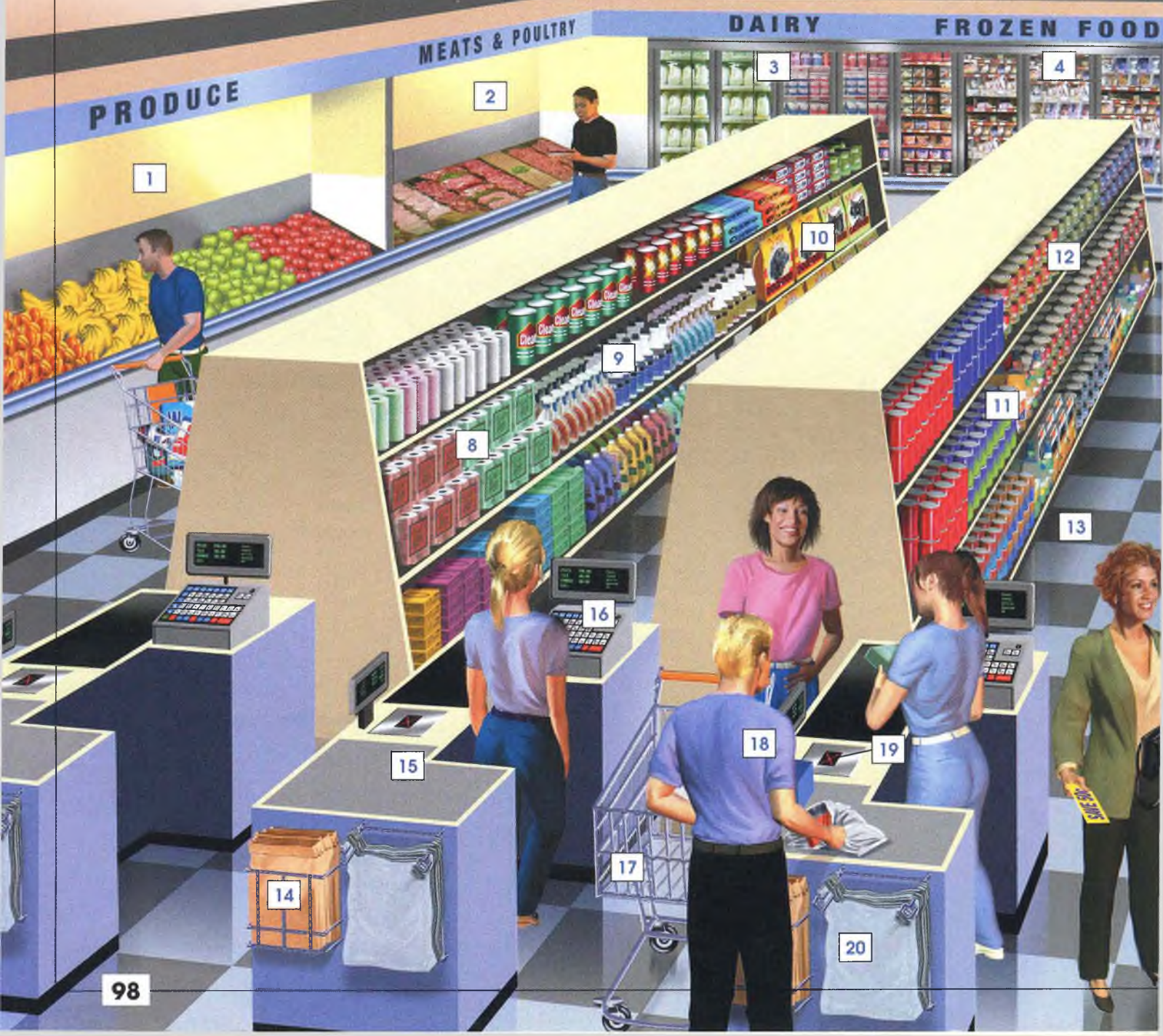

- | | | |
|---------------------|-----------------------|--------------------------|
| 1 produce | 8 paper products | 19 a barcode scanner |
| 2 meats and poultry | 9 household cleaners | 20 a plastic bag |
| 3 dairy products | 10 pet food | 21 a cashier / a checker |
| 4 frozen foods | 11 beverages | 22 groceries |
| 5 bakery | 12 canned goods | 23 a shopper |
| 6 a deli counter | 13 an aisle | 24 a shopping basket |
| 7 a scale | 14 a paper bag | |
| | 15 a checkout counter | Snacks |
| | 16 a cash register | 25 a candy bar |
| | 17 a shopping cart | 26 pretzels |
| | 18 a bagger | 27 (potato) chips |
| | | 28 popcorn |



Word Partnerships

the frozen food	aisle
the produce	section
the canned goods	
the bakery	
shop for	groceries
pick up	

Words in Action

- Where can you find the following items in the supermarket: *milk*, *water*, *bread*, *apples*, *paper towels*, *chicken*, and *ice cream*? Work with a partner.
 - Milk* is with the dairy products.
 - Water* is in the beverages section.
- What section do you go to first in a supermarket? What do you get there?



Restaurant

Words in Context

The first **restaurant** opened in Paris in 1765. The only thing on the **menu** was soup. There were no **appetizers** and no **desserts**. Restaurants have changed a lot since then. Now you can eat at a Chinese restaurant in Moscow or a Mexican restaurant in Beijing. The biggest restaurant in the world is the Royal Dragon in Bangkok. The dining room seats 5,000 **diners**. The **servers** wear roller skates!



- 1 a chef
- 2 a dishwasher
- 3 an apron
- 4 a server / a waitress
- 5 a busser / a busboy
- 6 a server / a waiter
- 7 a diner / a customer
- 8 a creamer
- 9 a vase
- 10 a sugar bowl
- 11 a tablecloth
- 12 a saltshaker
- 13 a pepper shaker
- 14 a bowl
- 15 a wine glass
- 16 a (water) glass
- 17 a high chair
- 18 a cup
- 19 a saucer
- 20 a menu
- 21 a fork
- 22 a napkin
- 23 a plate
- 24 a knife
- 25 a spoon
- 26 an appetizer
- 27 a main course
- 28 a dessert
- 29 a tray
- 30 a salad bar
- 31 a check / a bill



Word Partnerships

- | | |
|-----------|-------|
| a steak | knife |
| a butter | |
| a salad | fork |
| a dinner | |
| a soup | spoon |
| a dessert | |
| a serving | |
| a dinner | plate |
| a dessert | |
| a soup | bowl |
| a salad | |

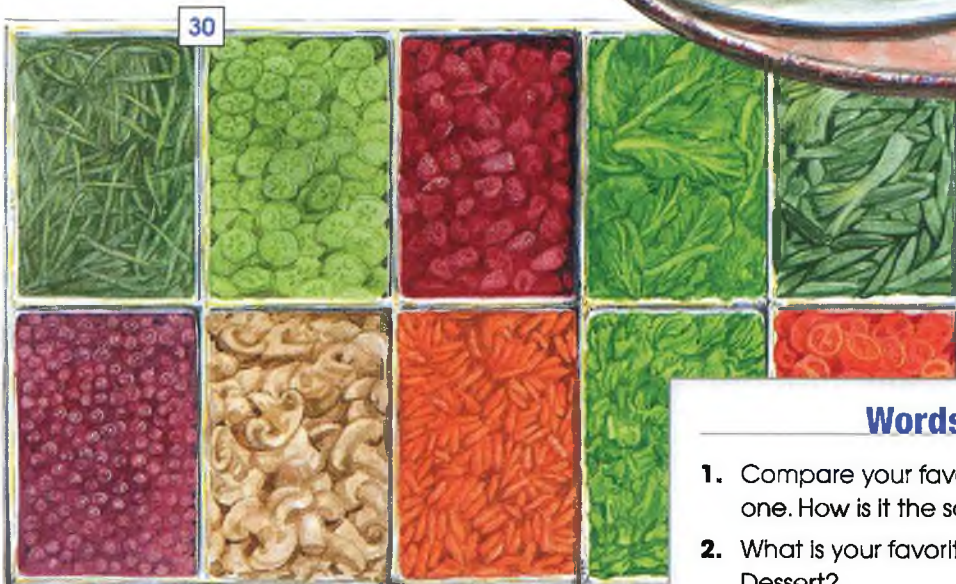
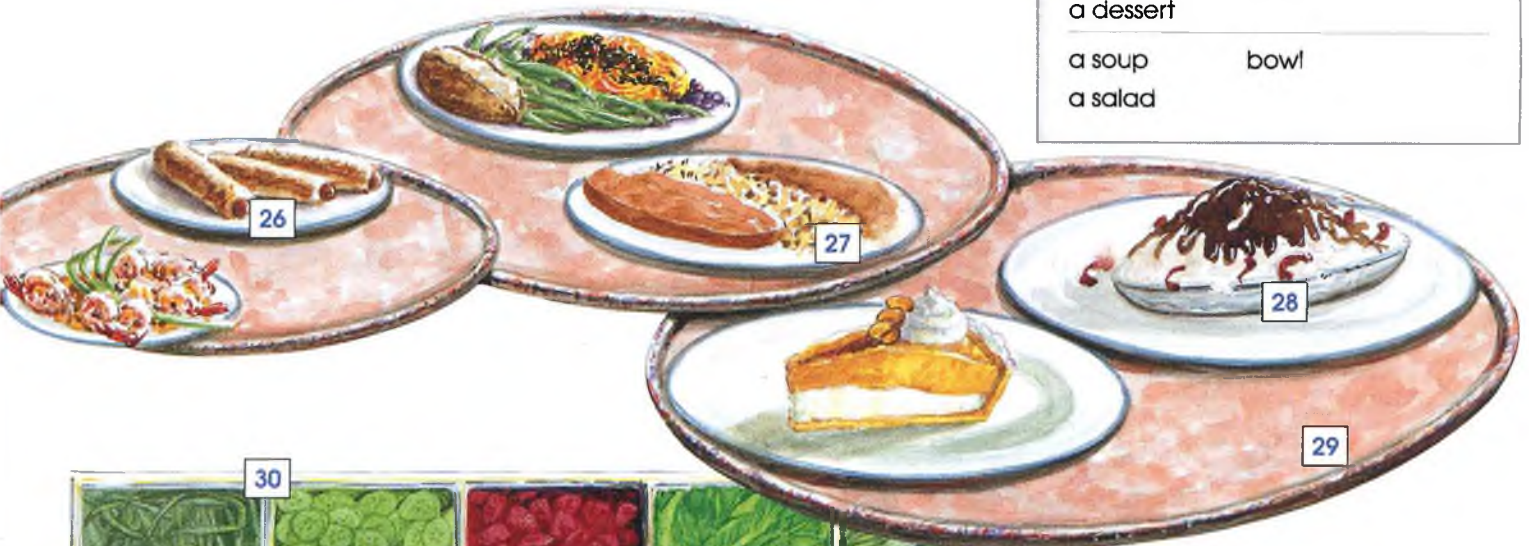

Words in Action

1. Compare your favorite restaurant with this one. How is it the same? How is it different?
2. What is your favorite appetizer? Main course? Dessert?



Order, Eat, Pay

Words in Context

I'm a waitress. I **wait on** lots of customers every night. Some customers are difficult. They **order** things that aren't on the menu. They **spill** their drinks. One customer left and didn't **pay** the check! But most customers are great. Some of them **compliment** me and **leave a big tip**. They're my favorite customers!



1 make a reservation

2 pour water

3 light a candle

4 carry a tray

5 set the table

6 wait on someone

7 look at the menu

8 butter the bread

9 spill a drink

10 order

11 take an order

12 drink

13 compliment someone

14 refill the glass

15 eat

16 serve a meal

17 ask for the check

18 signal the server

19 share a dessert

20 offer a doggie bag

21 thank the server

22 wipe the table

23 leave a tip

24 pay the check

25 clear the table / bus the table

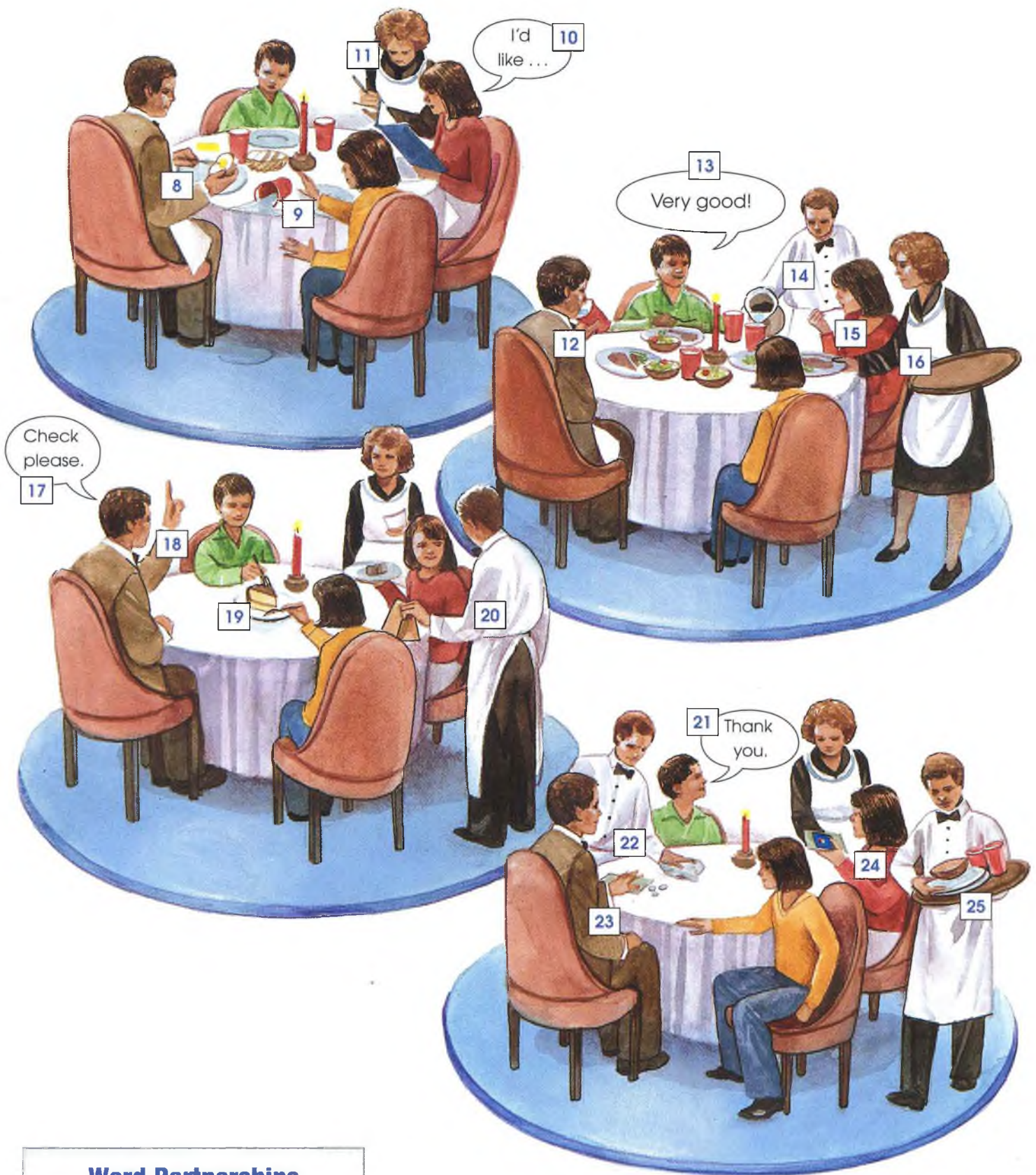

Word Partnerships

- | | |
|-------|-----------|
| eat | out |
| order | breakfast |
| | lunch |
| | dinner |
| | supper |
| | a meal |
| | a snack |

Words in Action

1. Think about the last time you ate out. Tell your class about five things you did at the restaurant.
2. Work with a partner. Act out a verb from the word list. Your partner will guess what you are doing. Take turns.



Clothes

Words in Context

The **clothes** we wear today come from around the world. For example, the **tie** is originally from Croatia. The **poncho** is from South America. The **business suit** originated in France in the 1700s. And a Bavarian immigrant named Levi Strauss made the first **blue jeans** in California in 1873. Now blue jeans are popular around the world.

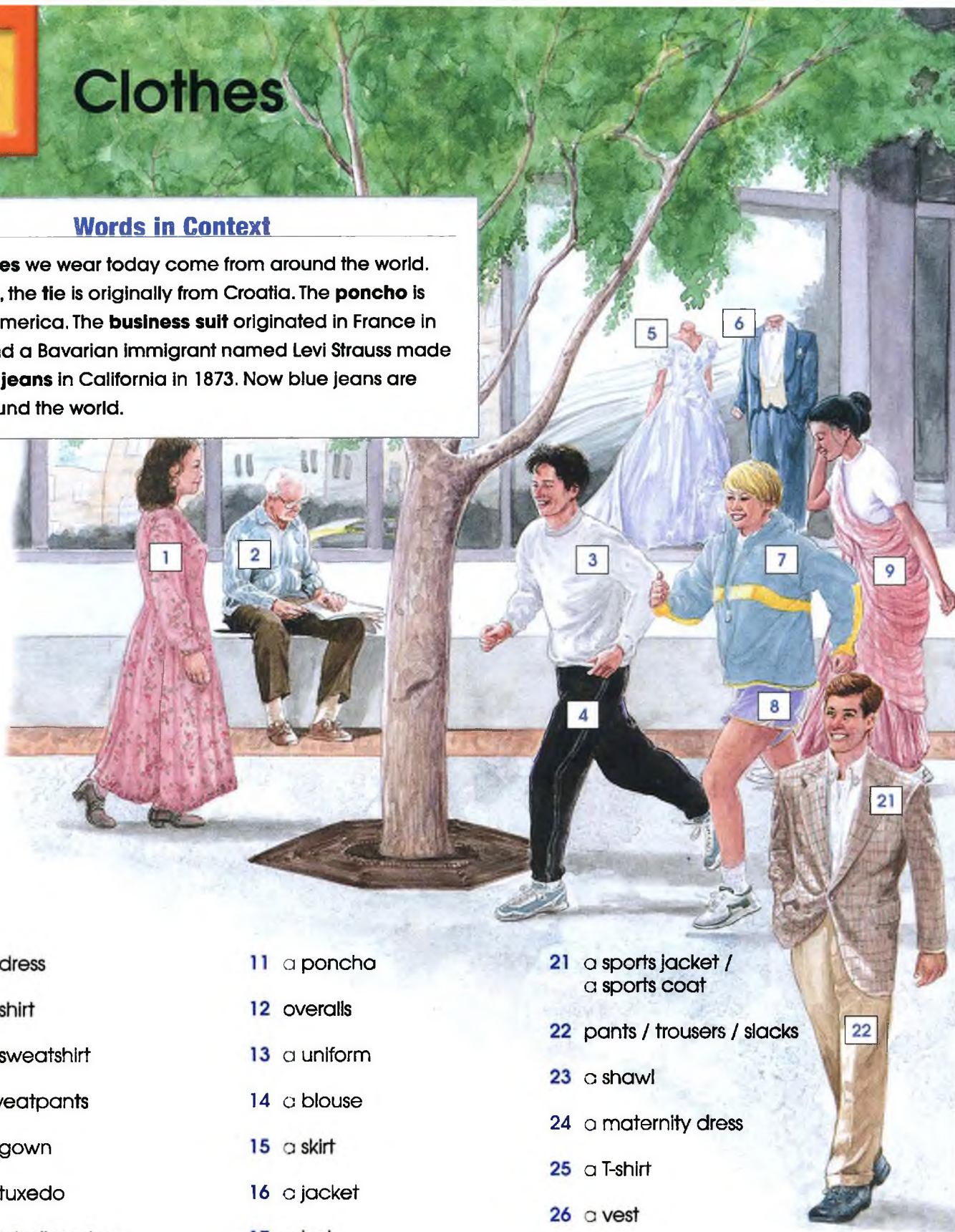

- | | | |
|-----------------|---------------------------|---------------------------------------|
| 1 a dress | 11 a poncho | 21 a sports jacket /
a sports coat |
| 2 a shirt | 12 overalls | 22 pants / trousers / slacks |
| 3 a sweatshirt | 13 a uniform | 23 a shawl |
| 4 sweatpants | 14 a blouse | 24 a maternity dress |
| 5 a gown | 15 a skirt | 25 a T-shirt |
| 6 a tuxedo | 16 a jacket | 26 a vest |
| 7 a windbreaker | 17 a hat | 27 (blue) jeans |
| 8 shorts | 18 a scarf | 28 a tie |
| 9 a sari | 19 a trench coat | 29 a (business) suit |
| 10 a raincoat | 20 a pullover / a sweater | 30 a coat |

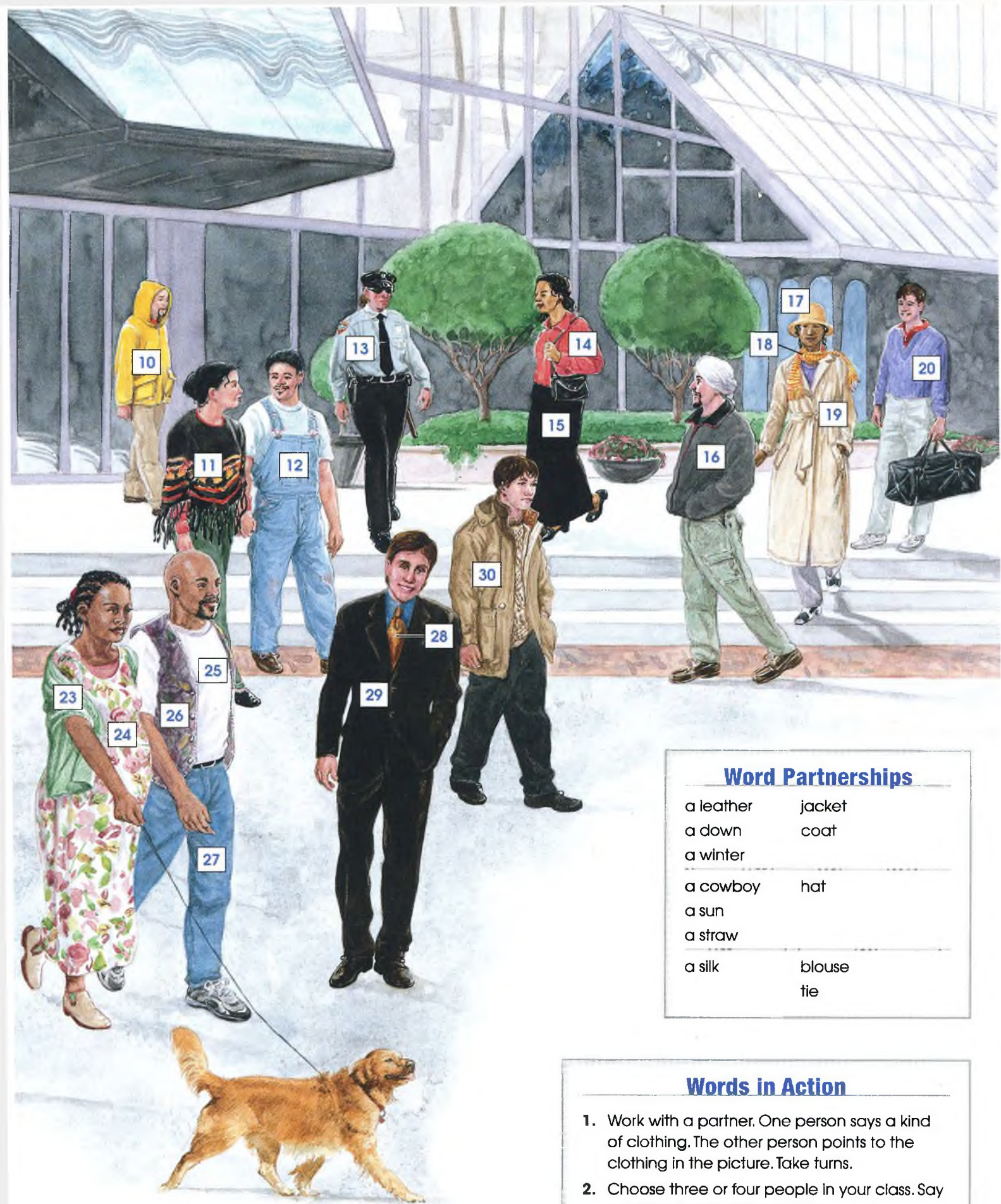

Word Partnerships

a leather	jacket
a down	coat
a winter	
a cowboy	hat
a sun	
a straw	
a silk	blouse
	tie

Words in Action

1. Work with a partner. One person says a kind of clothing. The other person points to the clothing in the picture. Take turns.
2. Choose three or four people in your class. Say what each person is wearing.



Sleepwear, Underwear, and Swimwear

Words in Context

Socks have a long history. Thousands of years ago, people wore animal skins on their feet. Knit socks appeared in the 3rd century in Egypt. They quickly became popular around the world. **Underwear** has a long history, too. Hundreds of years ago only very rich people wore underwear. However, in the 1700s, cotton became cheap and soon most people began to wear **boxer shorts**, **briefs**, or **underpants**.

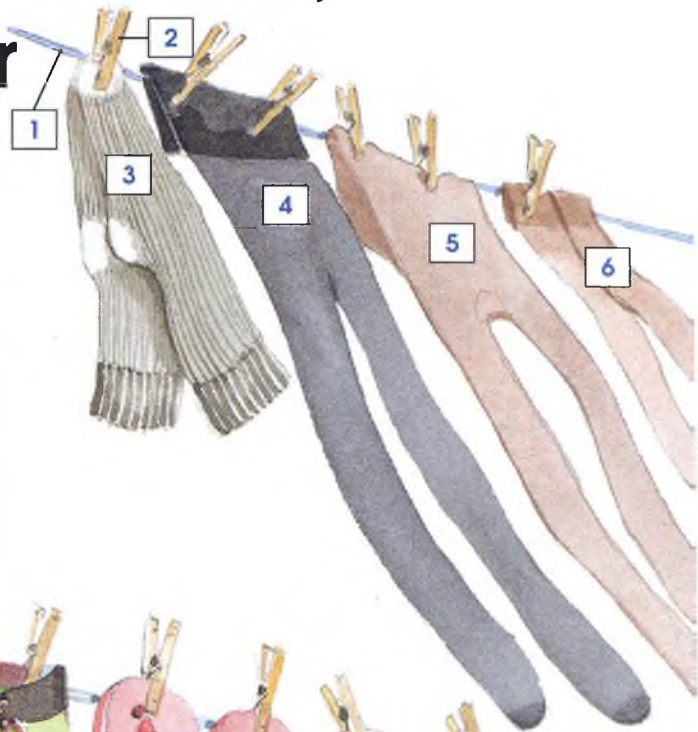

- 1 a clothesline
- 2 a clothespin
- 3 socks
- 4 tights
- 5 pantyhose / nylons
- 6 stockings
- 7 a swimsuit / a bathing suit
- 8 a bikini
- 9 (swimming) trunks
- 10 flip flops / thongs
- 11 slippers
- 12 a nightshirt
- 13 a (bath)robe
- 14 a nightgown
- 15 long underwear
- 16 a (blanket) sleeper
- 17 pajamas
- 18 a leotard
- 19 a bra
- 20 panties / underpants
- 21 a girdle
- 22 a camisole
- 23 a slip
- 24 an undershirt
- 25 a tank top
- 26 boxer shorts / boxers
- 27 briefs
- 28 an athletic supporter / a jockstrap

Word Partnerships

a terrycloth	(bath)robe
a silk	
a flannel	
knee	socks
sweat	
ankle	
dress	
a pair of	briefs
	boxer shorts
	socks
	slippers



Words in Action

1. Study the word list for three minutes. Then close your book. Write down as many of the words as you can remember. Write each word under one of these categories: *Sleepwear*, *Swimwear*, or *Underwear*.
2. Take turns describing an item of sleepwear or swimwear that you own.
 - *I have a blue nightshirt with yellow stars on it.*



Shoes and Accessories

Words in Context

Different **shoes** and **accessories** are popular in different cultures. For example, in Guatemala, many women wear **sandals**, long **earrings**, and bright **scarves**, **necklaces**, and **bracelets**. In India, women often wear a beautiful scarf, called a *dupatta*, and **gold rings**. What kinds of shoes and accessories are popular in your culture?



Word Partnerships

a pair of shoes

comfortable shoes

walking

running

tennis

a gold ring

an engagement

a wedding

a diamond

pierced earrings

clip-on

pearl

- | | | | |
|--------------------------|-------------------|---------------------|---------------------------------------|
| 1 gloves | 8 a necklace | 16 a briefcase | 24 a hiking boot |
| 2 a purse /
a handbag | 9 earrings | 17 a (high) heel | 25 a boot |
| 3 mittens | 10 a bracelet | 18 a pump | 26 a (knit) hat |
| 4 an umbrella | 11 a (wrist)watch | 19 a loafer | 27 a baseball cap /
a baseball hat |
| 5 suspenders | 12 a pin | 20 a clog | 28 earmuffs |
| 6 a belt | 13 jewelry | 21 a sandal | 29 a key chain |
| 7 a ring | 14 sunglasses | 22 a sneaker | |
| | 15 a wallet | 23 an athletic shoe | |

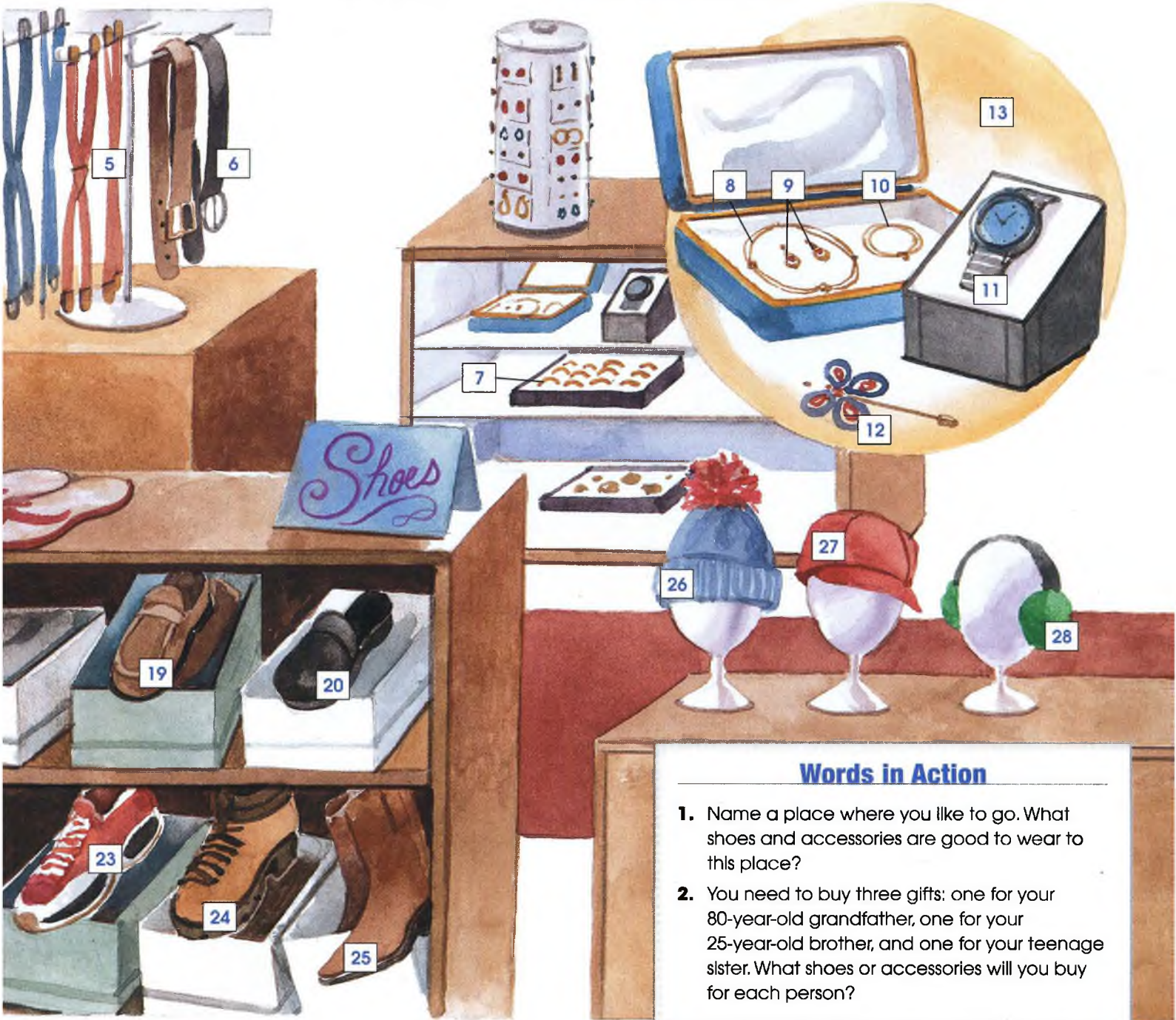

Words in Action

1. Name a place where you like to go. What shoes and accessories are good to wear to this place?
2. You need to buy three gifts: one for your 80-year-old grandfather, one for your 25-year-old brother, and one for your teenage sister. What shoes or accessories will you buy for each person?



Describing Clothes

Words in Context

Fashions come and go. For example, sometimes ties are **wide** and sometimes they're **narrow**. The length of **skirts** is always changing too. One year they're **long** and **straight**, and the next year they're **short** and **pleated**. It's hard to keep up with fashion!



Word Partnerships

fashionable	clothes
trendy	
designer	
work	
maternity	

7:00



Casual Clothes

8:00



Formal Clothes

1 a light jacket

2 a heavy jacket

3 a sleeveless shirt

4 a short-sleeved shirt

5 a long-sleeved shirt

6 a button-down shirt

7 a polo shirt

8 a wide tie

9 a narrow tie

10 flared jeans

11 straight leg jeans

12 baggy pants /
loose pants

13 a V-neck sweater

14 a crew neck sweater

15 a cardigan sweater

16 a turtleneck sweater

17 a tight skirt

18 a straight skirt

19 a pleated skirt

20 a short skirt

21 a long skirt

22 high heels

23 low heels

24 informal clothes /
casual clothes

25 formal clothes /
dress clothes



Words in Action

1. Describe the clothes you and other people in class are wearing.
2. Which items of clothing in the picture are in fashion? Are any of the clothes not in fashion?



Fabrics and Patterns

Words in Context

Fabrics can be natural or man-made. **Linen**, **cotton**, and **silk** are natural fabrics. Linen and cotton come from plants. Silk comes from silk worms. Polyester is a man-made fabric. It is made from chemicals. It is now the most common fabric in the world.



Word Partnerships

a wool jacket
sweater
coat
scarf

a silk tie
robe
dress



Fabrics

- 1 cotton
- 2 corduroy
- 3 velvet
- 4 silk
- 5 leather
- 6 denim
- 7 linen
- 8 suede
- 9 cashmere
- 10 nylon
- 11 lace
- 12 wool

Patterns

- 13 solid
- 14 print
- 15 polka dot
- 16 floral
- 17 paisley
- 18 checked
- 19 plaid
- 20 striped
- 21 embroidered



Words in Action

1. Work with a partner. Describe your partner's clothes.
 - *You're wearing brown corduroy pants and a blue and white striped cotton shirt.*
2. Design an outfit. Decide on the fabrics and patterns. Draw the outfit and describe it to your class.

Buying, Wearing, and Caring for Clothes

Words in Context

Different clothes have different care instructions. Jeans are easy. You can **wash** them in the washing machine and then **dry** them in the dryer. However, a wool shirt needs special care. You shouldn't wash a wool shirt. Instead, you should **dry clean** it. To prevent wrinkles, always **hang up** clothes.



1 go shopping

5 buy

10 button

15 unzip

2 look for a jacket

6 take home

11 buckle

16 unbuckle

3 go into a dressing room

7 cut off

12 roll up

17 take off

4 try on

8 put on

13 wear

18 wash

9 zip

14 unbutton

19 dry



Word Partnerships

- 20 dry clean
- 21 mend / repair
- 22 sew on
- 23 iron / press
- 24 hang (up)

hang it	on a hook
	on a hanger
	in the closet
wash it	in cold water
	in hot water
	by hand
zip	up
button	

Words in Action

1. Pretend to do one of the actions on the word list. Your partner will guess what you are doing. Take turns.
2. Explain how you care for your favorite piece of clothing.
 - *I never wash my leather jacket in the washing machine. I dry clean it.*



Sewing and Laundry

Words in Context

Fashion designer Josie Natori comes from the Philippines. She sells her clothes all over the world. Her company started very small. At first, Natori worked alone in her living room with a **sewing machine, pins, needles, buttons, thread, and scissors.** Now her company has offices in Manila, Paris, and New York.



1 an ironing board

2 an iron

3 fabric softener

4 (laundry) detergent

5 bleach

6 a dryer

7 a washer /
a washing machine

8 wet clothes

9 dry clothes

10 a laundry basket



- 11 a hanger
- 12 a collar
- 13 a pocket
- 14 a buttonhole
- 15 a button
- 16 a sleeve
- 17 a cuff
- 18 a hem
- 19 a tailor
- 20 a sewing machine
- 21 a pin
- 22 a pincushion
- 23 a (pair of) scissors
- 24 a zipper
- 25 a seam
- 26 a thimble
- 27 thread
- 28 a tape measure
- 29 a needle
- 30 a safety pin

Word Partnerships

- | | |
|-----------|---------|
| a wire | hanger |
| a plastic | |
| a shirt | pocket |
| a pants | |
| a jacket | |
| long | sleeves |
| short | |

Words in Action

1. Find the following things on your classmates' clothes: *a buttonhole, a collar, a cuff, a pocket, a sleeve, a hem.*
2. Which of the items in the picture do you have in your home?



Vehicles and Traffic Signs

Words in Context

Do you need a new car or truck? There is a lot to think about. Do you have children? A **compact car** may be too small. People with children often drive large **vehicles** like **station wagons**, **sedans**, and **SUVs**. Do you like to camp? An **RV** may be good for you. Do you like adventure? You might like a **motorcycle**. Do you often need to move large things? You may want a **pickup truck**. There are so many vehicles to choose from!

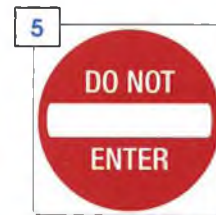

Signs

- 1 one way
- 2 stop
- 3 hospital
- 4 do not pass
- 5 do not enter
- 6 no left turn
- 7 railroad crossing
- 8 school zone
- 9 pedestrian crossing
- 10 yield
- 11 no U-turn

Vehicles

- 12 a school bus
- 13 a tow truck
- 14 a garbage truck
- 15 a pickup (truck)
- 16 an RV
- 17 a minivan
- 18 a limousine / a limo
- 19 a sedan
- 20 a van
- 21 a dump truck
- 22 an SUV

- 23 a trailer
- 24 a sports car
- 25 a semi / a tractor trailer
- 26 a police car
- 27 an ambulance
- 28 a fire engine
- 29 a station wagon
- 30 a compact (car)
- 31 a convertible
- 32 a motorcycle



Word Partnerships

drive	a convertible
	a truck
	an SUV
ride	a motorcycle
ride in	a limousine
ride on	a bus

Words in Action

1. Work with a partner. Make a list of the five largest vehicles in the word list. Make another list of the five smallest vehicles.
2. Imagine you have enough money to buy a new vehicle. What vehicle will you buy? Explain your choice to the class.



Parts of a Car

Words in Context

Car Safety Tips

- Always wear a **seat belt**.
- Put children in **child car seats**.
- Always use **headlights** in bad weather.
- Check your **brakes** at least twice a year.
- Check your **tires** frequently for damage.

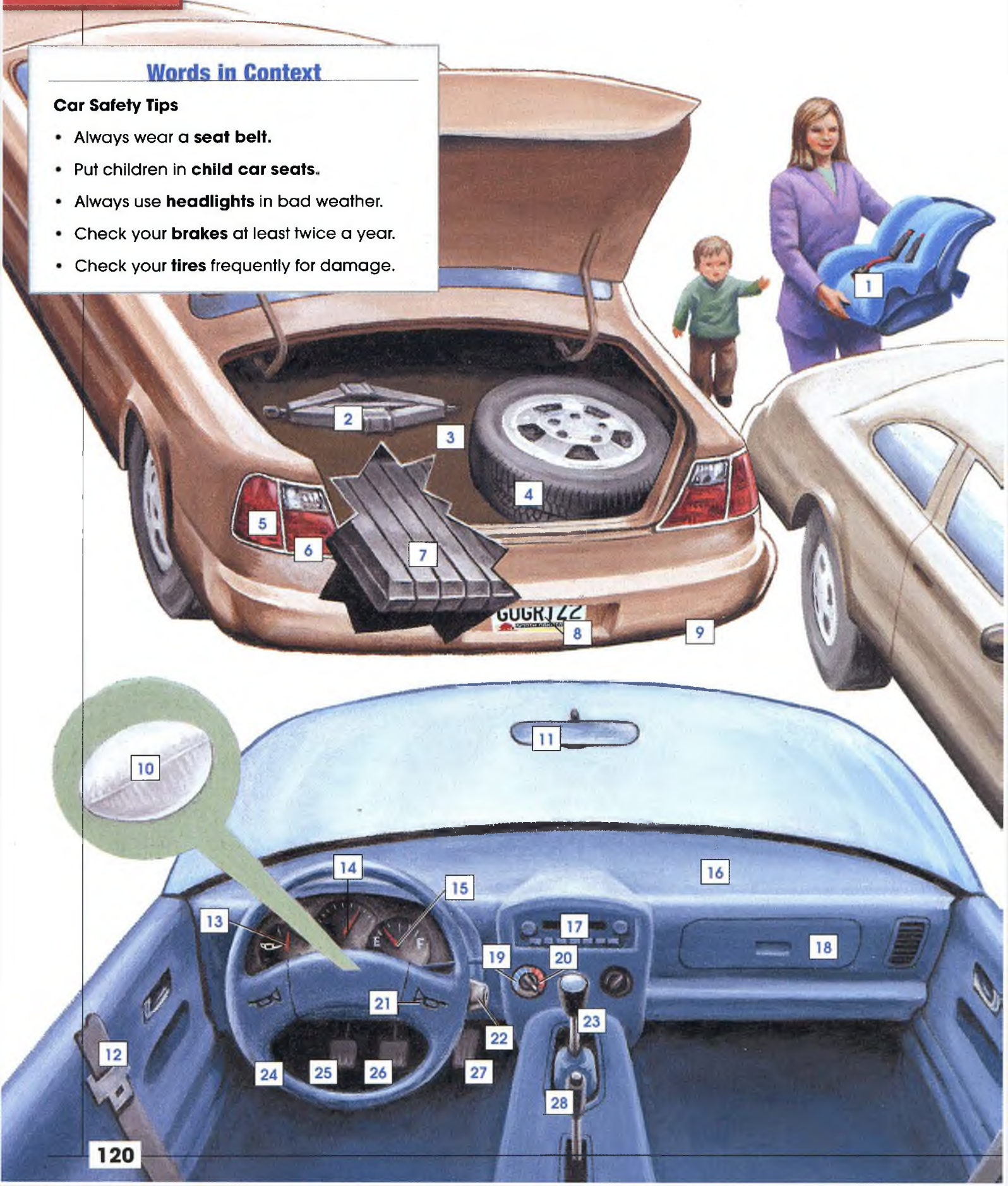

- | | | | |
|--------------------|----------------------|---------------------------------|------------------------|
| 1 a child car seat | 9 a bumper | 18 a glove compartment | 28 an emergency brake |
| 2 a jack | 10 an air bag | 19 air conditioning | 29 a windshield wiper |
| 3 a trunk / a boot | 11 a rearview mirror | 20 heater | 30 a hood |
| 4 a tire | 12 a seat belt | 21 a horn | 31 a fender |
| 5 a taillight | 13 an oil gauge | 22 an ignition | 32 an engine / a motor |
| 6 a brake light | 14 a speedometer | 23 a gearshift | 33 a battery |
| 7 a gas tank | 15 a gas gauge | 24 a steering wheel | 34 jumper cables |
| 8 a license plate | 16 a dashboard | 25 a clutch | 35 a radiator |
| | 17 a radio | 26 a brake pedal | 36 a turn signal |
| | | 27 an accelerator / a gas pedal | 37 a headlight |

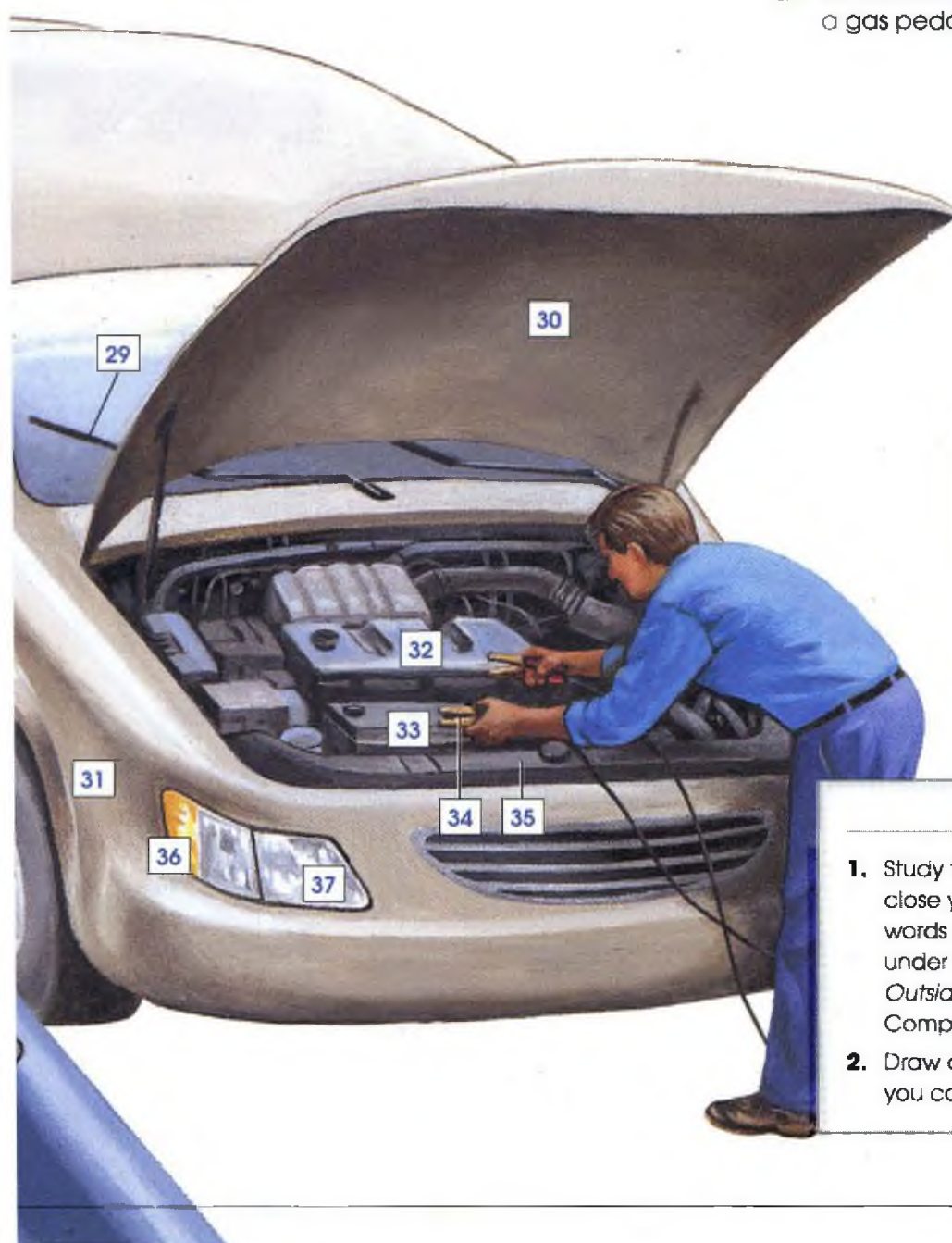

Word Partnerships

open	the hood
close	the trunk
check	the battery
	the rearview mirror
a spare	fire
a flat	

Words in Action

1. Study the word list for three minutes. Then close your book. Write down as many of the words as you can remember. Write each word under one of these categories: *Inside the car*, *Outside the car*, and *Under the hood*. Compare your lists with a partner.
2. Draw a car. Label as many parts of the car as you can, without looking at the word list.



Road Trip

Words in Context

Here are some tips for a good **road trip**. Before you **leave**, make sure your car is running well. **Get** gas, **check** the oil, and **put** air in your tires. Take plenty of coins to **pay** tolls. Once you are on the road, **turn on** your headlights. Finally, make sure you **get off** the highway for a short break every two or three hours.

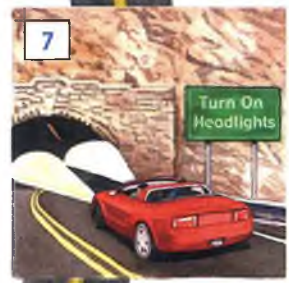
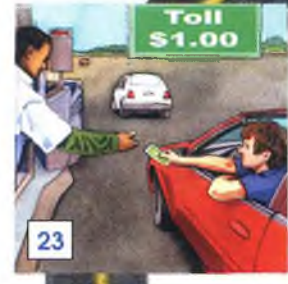



- 1 pack
- 2 leave
- 3 drive
- 4 ask for directions
- 5 speed up
- 6 get a speeding ticket
- 7 turn on the headlights
- 8 slow down
- 9 get off the highway
- 10 stop
- 11 look at a map
- 12 get on the highway
- 13 pass a truck
- 14 honk (the horn)
- 15 get gas
- 16 check the oil
- 17 wash the windshield
- 18 put air in the tires
- 19 have an accident
- 20 pull over
- 21 have a flat (tire)
- 22 change the tire
- 23 pay a toll
- 24 arrive at the destination
- 25 park (the car)

Word Partnerships

pack	a suitcase a bag
stop	at a red light for gas
turn on	the windshield wipers the radio the air conditioning

Words in Action

1. Work with a partner. Act out a verb on the list. Your partner will guess the verb. Take turns.
2. Plan your "dream" road trip. Where will you go? What will you do on the trip?



Airport

Words in Context

Air travel is changing. **Airports** now have **automated check-in machines**. A **passenger** can quickly check in, choose a **seat**, and get a **boarding pass**. In the future, some **airplanes** will be bigger and some will fly much faster.

Airport

- 1 a terminal
- 2 a ticket
- 3 a photo ID
- 4 a ticket counter / a check-in counter
- 5 baggage / luggage
- 6 a passenger
- 7 an automated check-in machine
- 8 a boarding pass



- 9 a metal detector
- 10 a security checkpoint
- 11 arrival and departure monitors
- 12 a helicopter
- 13 a runway
- 14 a gate
- 15 a pilot
- 16 a carry-on bag
- 17 customs
- 18 a customs (declaration) form
- 19 the baggage claim (area)

- 20 immigration
- 21 a line

Airplane / Plane

- 22 first class
- 23 economy (class) / coach (class)
- 24 an overhead compartment
- 25 an emergency exit
- 26 a flight attendant
- 27 a seat
- 28 a seat belt
- 29 an aisle

Word Partnerships

an aisle	seat
a middle / a center	
a window	
an electronic / an e-	ticket
a paper	
an arrival	terminal
a departure	
an international	



Words in Action

1. Work with a partner. One person says an airport or airplane word. The other points to the item in the picture. Take turns.
2. Make three lists: *people you see at an airport*, *areas you see at an airport*, and *things you see at an airport*.



Taking a Flight

Words in Context

Air Travel Tips

- **Check in** early.
- When you **board** the plane, **stow** your carry-on bag.
- Drink plenty of water.
- **Stretch** often.
- **Ask for** a pillow. Put your seat back, and try to sleep as much as possible.

- 1 check in
- 2 show your ID
- 3 check your baggage
- 4 get your boarding pass
- 5 go through security
- 6 check the monitors
- 7 wait at the gate
- 8 board the plane
- 9 find your seat
- 10 stow your carry-on bag
- 11 turn off your cell phone
- 12 fasten your seat belt
- 13 take off
- 14 ask for a pillow
- 15 turn on the overhead light
- 16 put on your headphones
- 17 listen to music
- 18 put your tray table down
- 19 stretch
- 20 choose a meal
- 21 land
- 22 unfasten your seat belt
- 23 get off the plane
- 24 claim your bags





Word Partnerships

wait	for a boarding call in line
go through	a metal detector customs immigration

Words in Action

1. Work with a partner. Pretend to do one of the actions on the word list. Your partner will guess what action you are doing. Take turns.
2. Make a list of things you can do on a plane to be safe. Make another list of things you can do to be comfortable.



Public Transportation

Words in Context

There are three ways to get from JFK Airport in New York to Manhattan. The first way is by **cab**. You can get a cab at the **taxi stand**. The **fare** is about \$35.00. The second way is by **bus**. You can catch a bus from the **bus stop** outside the airport. The **ticket** is about \$13.00. The bus will take you to a Manhattan **train station** or hotel. The third way is by **subway**. Go to the JFK Airport **subway station**. The subway will take you into Manhattan. This is the cheapest way. It costs only \$2.00.



- | | |
|--------------------------------|---------------------|
| 1 a taxi stand | 13 a conductor |
| 2 a meter | 14 a track |
| 3 the fare | 15 a strap |
| 4 a taxi / a cab | 16 a (subway) line |
| 5 a taxi driver / a cab driver | 17 a ferry |
| 6 a passenger | 18 a subway (train) |
| 7 a bus stop | 19 a platform |
| 8 a bus driver | 20 a token |
| 9 a bus | 21 a fare card |
| 10 a ticket window | 22 a schedule |
| 11 a ticket | 23 a turnstile |
| 12 a train | |



TO TRAIN AND SUBWAY



7



Word Partnerships

a bus	station
a train	
a subway	
take	a taxi / a cab
	a ferry
	a train
	a bus
catch	a train
miss	a bus

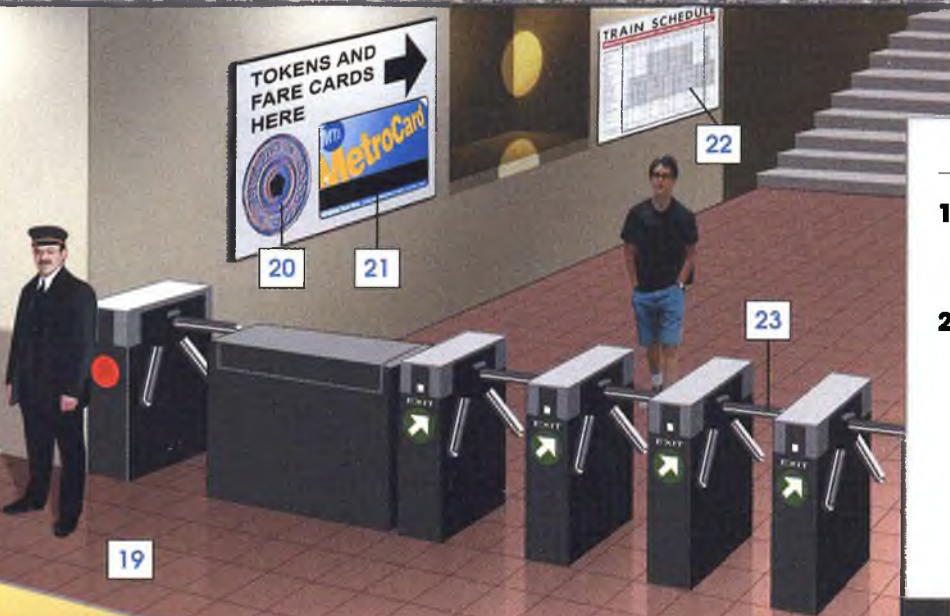

Words in Action

1. What kind of public transportation do you use? Where do you get on? What is the fare?
2. One student names a form of public transportation. Other students make up sentences about that form of transportation in your town or city.
 - Student A: *the subway*
 - Student B: *You need a fare card.*
 - Student C: *There's a subway station a block from the school.*



Up, Over, Around

Words in Context

Roller coaster rides are exciting. You go **up** a track very, very slowly. Then suddenly you go **over** the top and race **down** the track. Most roller coaster rides go **around** several sharp curves. Some even go **upside down**. But when the ride is over, people often want to do it again!

- 1 straight
- 2 past the house
- 3 into the tunnel
- 4 through the tunnel
- 5 out of the tunnel
- 6 behind the building
- 7 toward the rocks
- 8 between the flags
- 9 around the trees
- 10 up
- 11 down
- 12 upside down
- 13 under the waterfall
- 14 over the water
- 15 left
- 16 right
- 17 across the river
- 18 along the river
- 19 north
- 20 east
- 21 south
- 22 west

Word Partnerships

go	through
	straight
	across
turn	left
make a	right
take a	

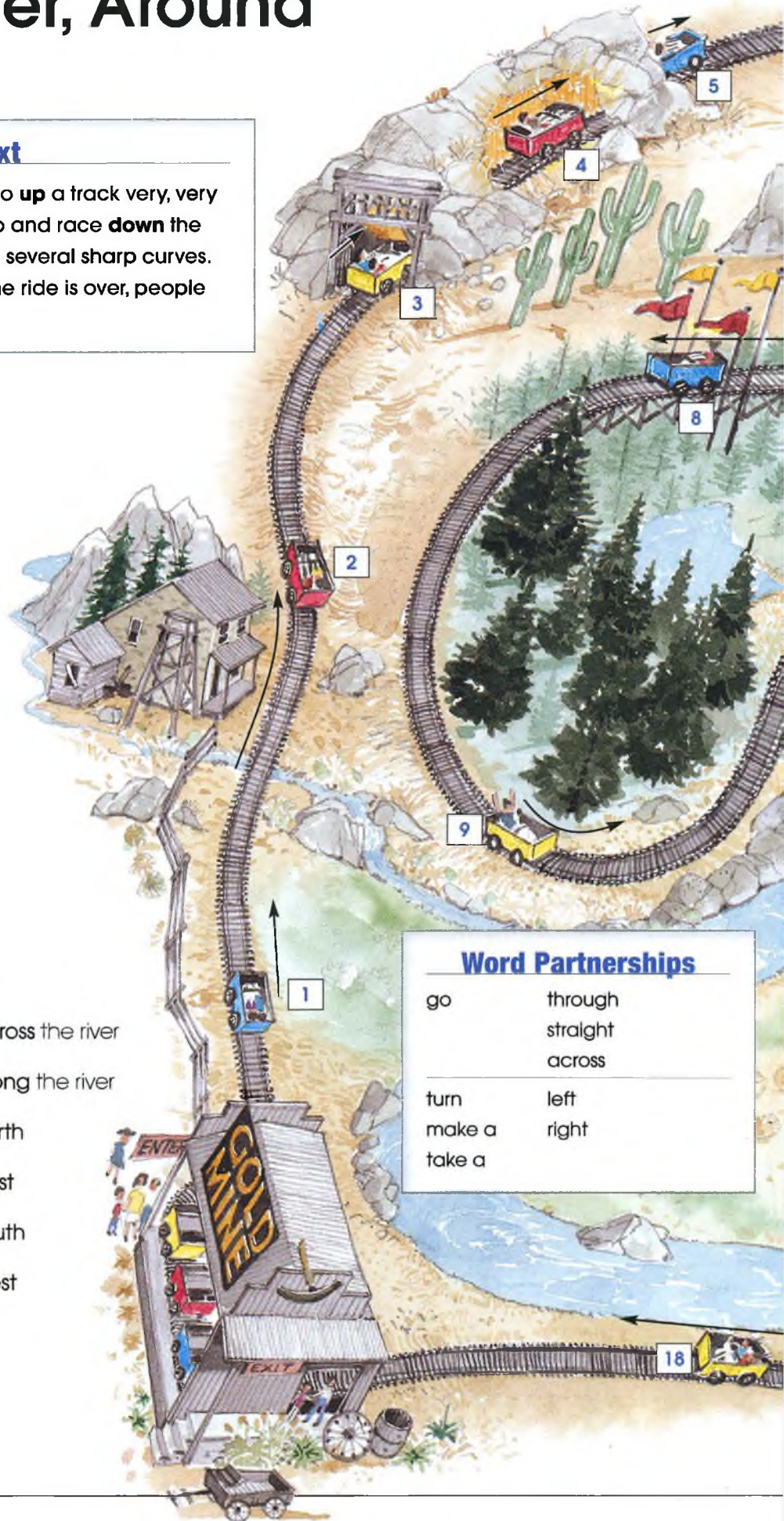

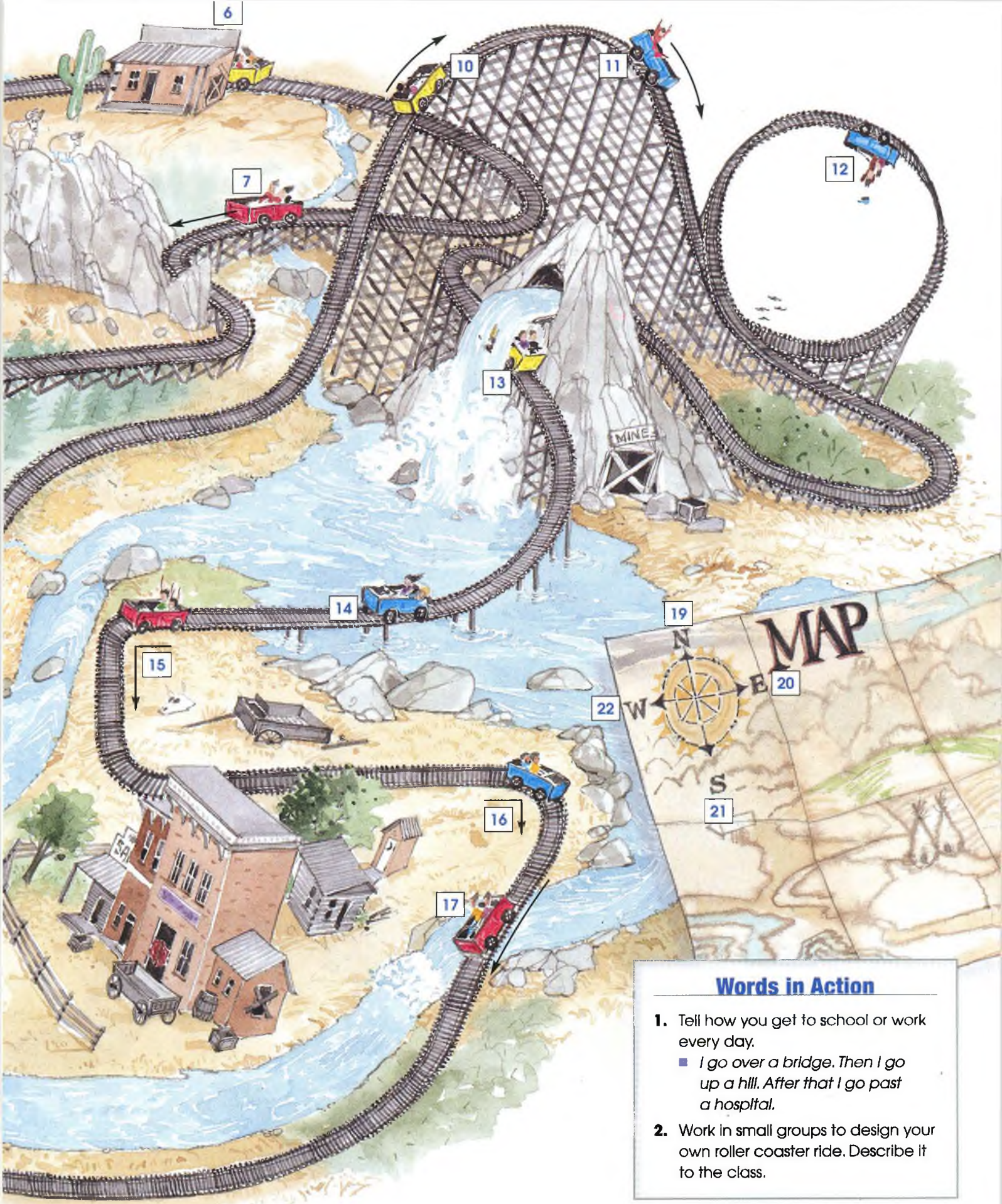

Words in Action

1. Tell how you get to school or work every day.
 - *I go over a bridge. Then I go up a hill. After that I go past a hospital.*
2. Work in small groups to design your own roller coaster ride. Describe it to the class.



The Human Body

Words in Context

Always prepare for exercise. A ten-minute warm-up will stretch your **muscles** and get your **body** ready. Roll your **head** around in a circle. Move your **shoulders** up and down. Stretch your **arms** out and swing them in a circle. Bend your **knees**, and then stretch out your **legs**. Now you are ready to exercise.

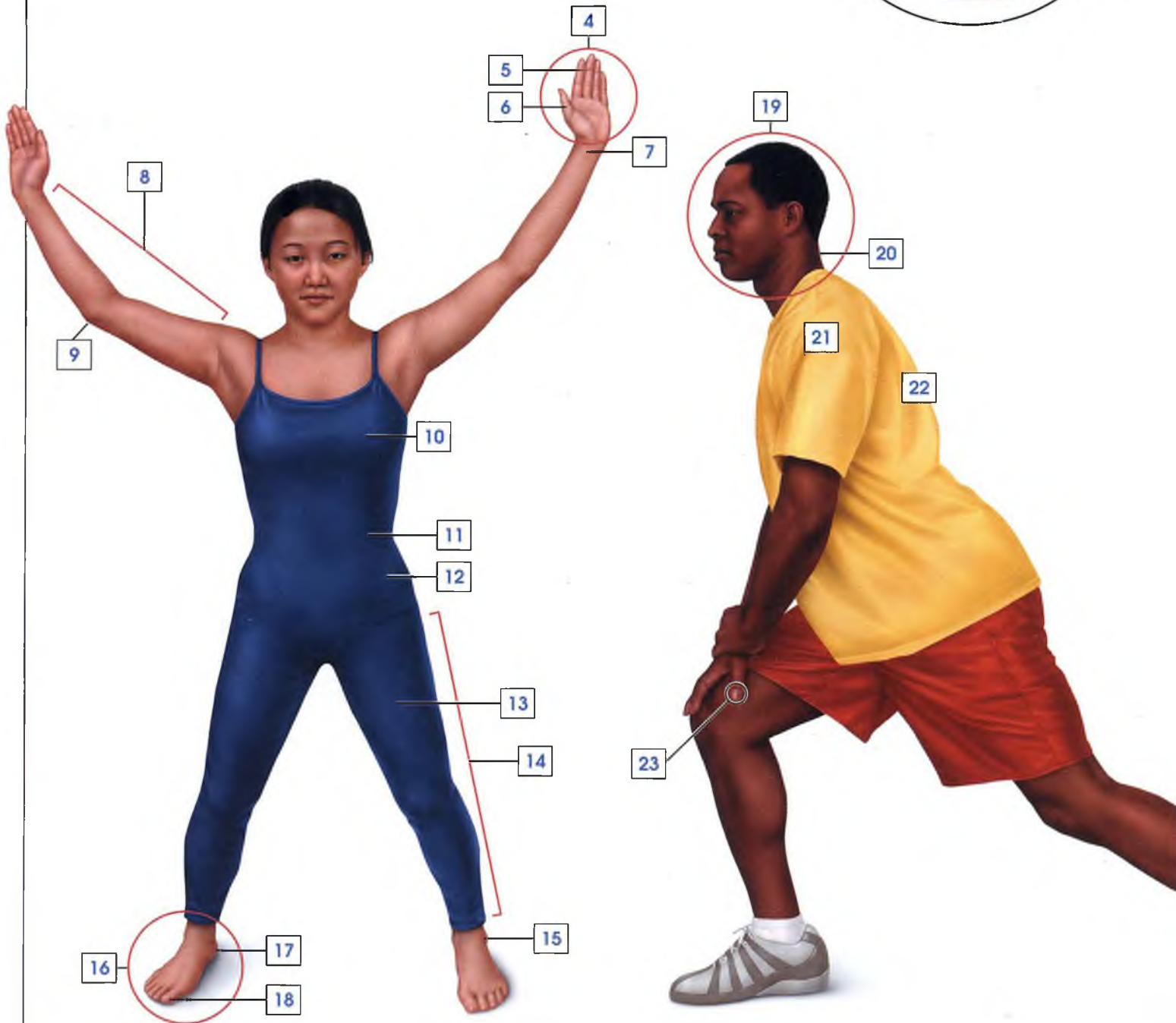
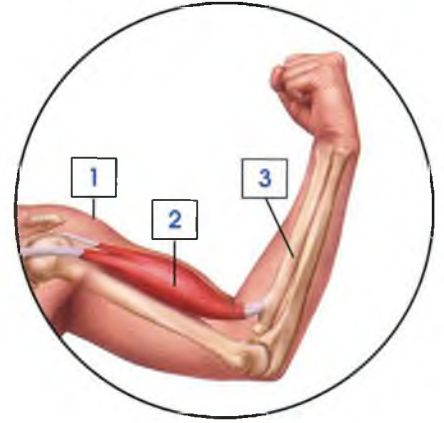

Word Partnerships

ring
index
pinky

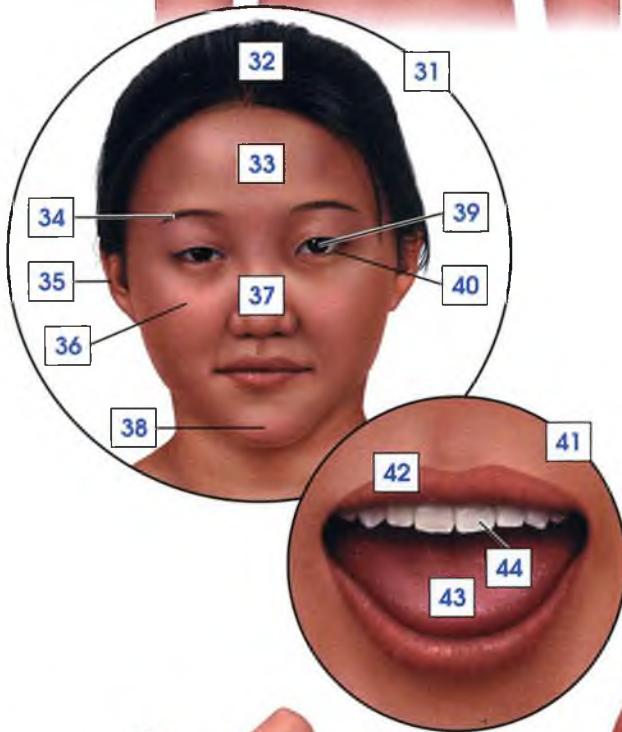
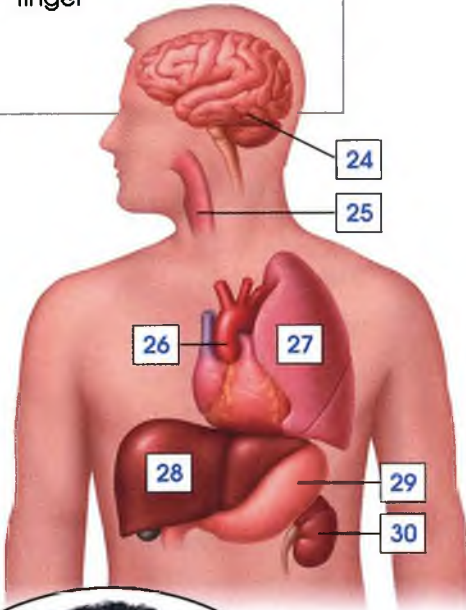

- | | | |
|-------------|-------------------|---------------|
| 1 skin | 17 a heel | 33 a forehead |
| 2 a muscle | 18 a toe | 34 an eyebrow |
| 3 a bone | 19 a head | 35 an ear |
| 4 a hand | 20 a neck | 36 a cheek |
| 5 a finger | 21 a shoulder | 37 a nose |
| 6 a thumb | 22 a back | 38 a chin |
| 7 a wrist | 23 a (finger)nail | 39 an eye |
| 8 an arm | 24 a brain | 40 eyelashes |
| 9 an elbow | 25 a throat | 41 a mouth |
| 10 a breast | 26 a heart | 42 a lip |
| 11 a waist | 27 a lung | 43 a tongue |
| 12 a hip | 28 a liver | 44 a tooth |
| 13 a thigh | 29 a stomach | 45 a knee |
| 14 a leg | 30 a kidney | 46 a chest |
| 15 an ankle | 31 a face | 47 buttocks |
| 16 a foot | 32 hair | |

Words in Action

1. Work with a partner. Cover the word list. One person points to a part of the body in the picture. The other says the word for the part. Take turns.
2. Work with a partner. Take turns giving and following instructions. Use words from the word list.
 - Student A: *Touch your head.*
 - Student B: (Touches her head.) *Raise your hand.*
 - Student A: (Raises her hand.)



Illnesses, Injuries, Symptoms, and Disabilities

Words in Context

There are many reasons people visit the doctor's office. In winter, many people get a **sore throat**, a **cough**, or the **flu**. In summer, bad **sunburns** are common. **Earaches**, **stomachaches**, and **backaches** are common problems all year round.

Word Partnerships

a head	cold
a bad	
catch	a cold
have	a cold
	the flu
	a sore throat
feel	dizzy
	nauseous



- | | | | |
|---------------------|-------------------------------|--------------|------------------|
| 1 an earache | 13 a headache | 25 a blister | 28 a bee sting |
| 2 asthma | 14 the flu | 26 a rash | 29 a bloody nose |
| 3 a cough | 15 a fever /
a temperature | 27 a sunburn | 30 a bruise |
| 4 lice | 16 arthritis | | |
| 5 a cold | 17 a backache | | |
| 6 chicken pax | 18 blind | | |
| 7 mumps | 19 nauseous | | |
| 8 a sore throat | 20 dizzy | | |
| 9 measles | 21 deaf | | |
| 10 a sprained wrist | 22 acne | | |
| 11 a swollen ankle | 23 a cut | | |
| 12 a stomachache | 24 a burn | | |

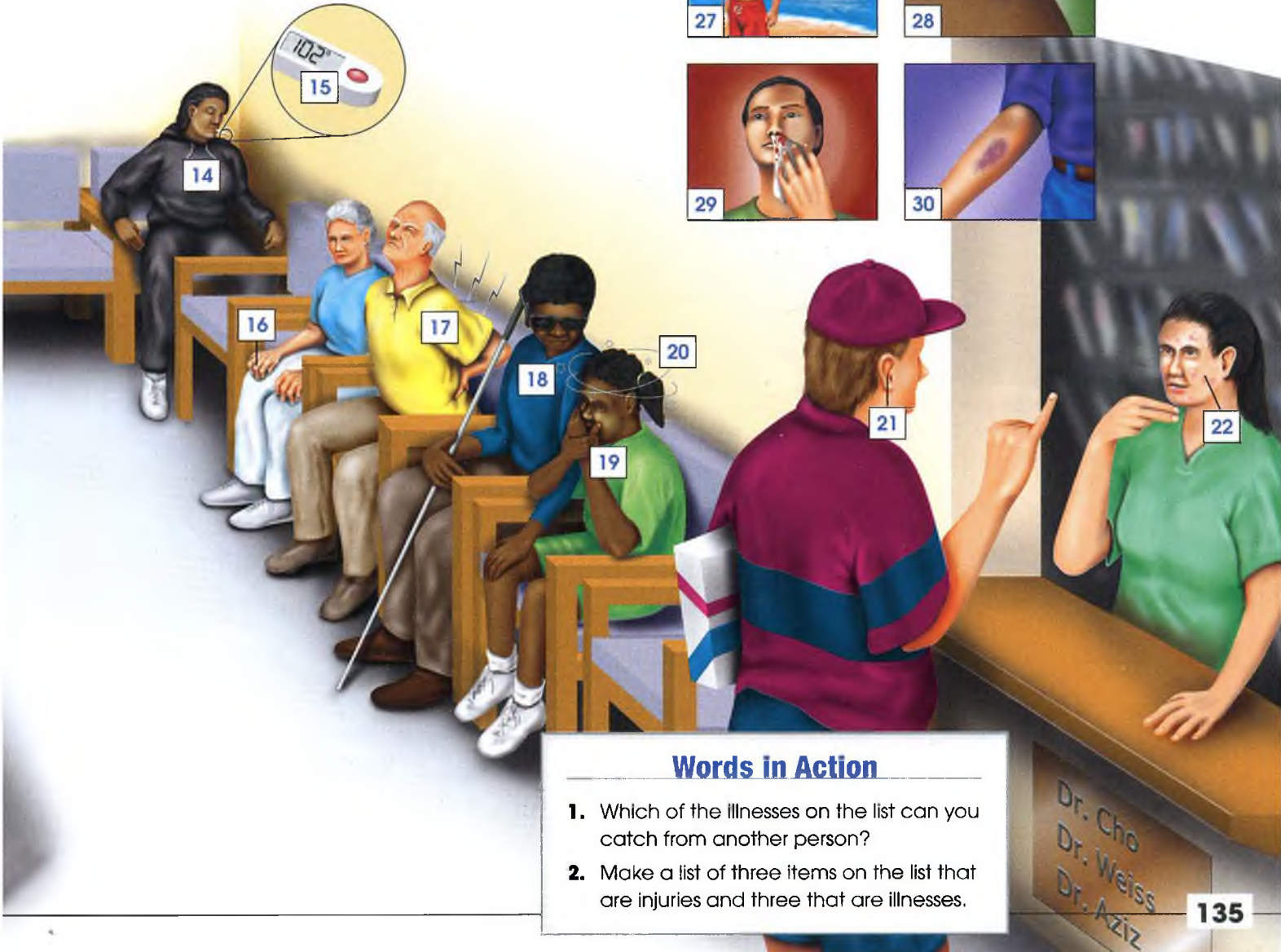
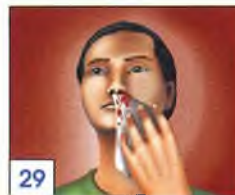

Words in Action

1. Which of the illnesses on the list can you catch from another person?
2. Make a list of three items on the list that are injuries and three that are illnesses.

Dr. Cho
Dr. Weiss
Dr. Aziz



Hurting and Healing

Words in Context

Are you **coughing** and **sneezing**? You probably have a cold. **Drink** plenty of fluids and **rest** as much as possible. Do you feel hot? **Take** your temperature. You might have the flu. **Make** an appointment with your doctor. He will **examine** you. You may need to **take pills** or get a shot. Follow your doctor's instructions. You will soon **feel better**.



1 be in pain

7 choke

13 have a heart attack

2 be unconscious

8 cut yourself

14 get a(n electric) shock

3 bleed

9 drown

15 fall

4 be in shock

10 swallow poison

5 break a leg

11 overdose (on drugs)

6 burn yourself

12 have an allergic reaction

Word Partnerships

be	injured	
	hurt	

feel	much	better
	a little	



16 cough

17 sneeze

18 vomit / throw up

19 take your temperature

20 call the doctor

21 make an appointment

22 examine the patient

23 check his blood pressure

24 draw his blood

25 give him a shot

26 rest

27 take a pill

28 drink fluids

29 feel better

Words in Action

1. Look at page 136. Which things on the list are more likely to happen to adults? Which are more likely to happen to children?
2. Work with a partner. One person pretends to have one of the medical problems on the list. The other guesses the problem. Take turns.



Hospital

Words in Context

Here are some things to look for in a **hospital**:

- Are the **doctors** and **nurses** friendly and helpful?
- Are there plenty of nurses at each **nurses' station**?
- Are the **patients** happy with the hospital?

- 1 a nurses' station
- 2 a nurse
- 3 an intensive care unit
- 4 an IV / an intravenous drip
- 5 an operating room
- 6 an X-ray
- 7 an anesthesiologist
- 8 an operating table
- 9 blood

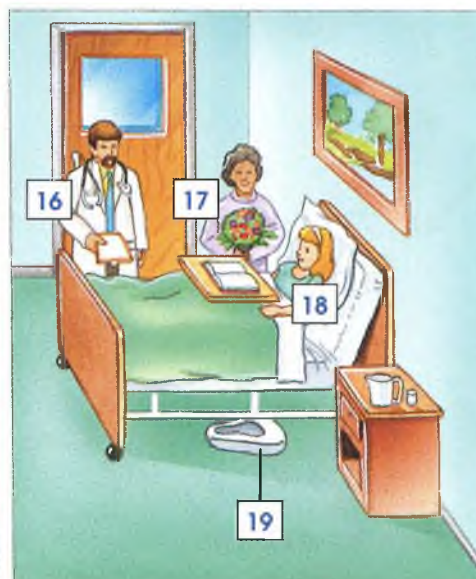
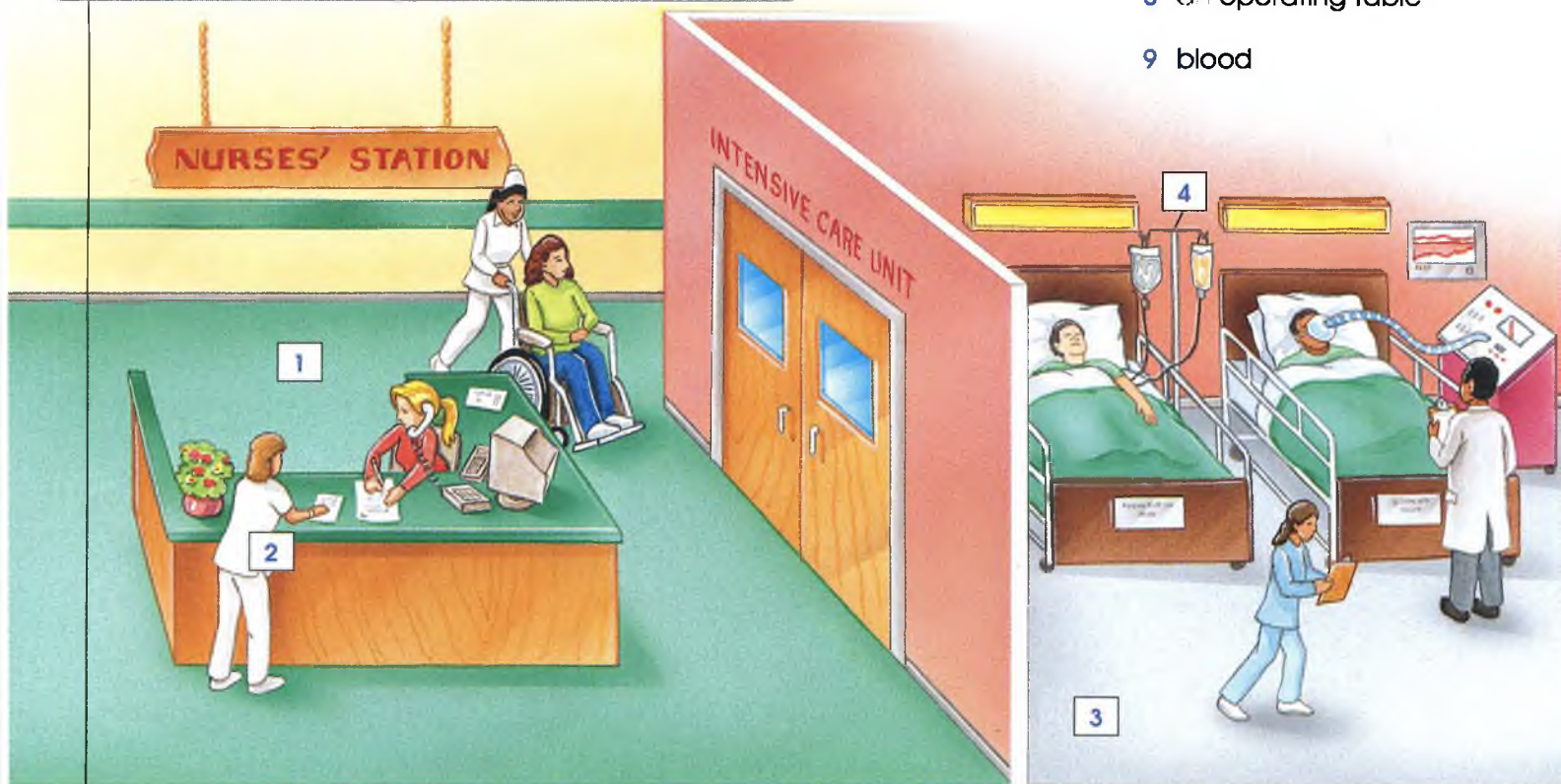

10 a surgeon

11 an operation

12 latex gloves

13 a (surgical) mask

14 a lab / a laboratory

15 a lab technician

16 a doctor

17 a visitor

18 a patient

19 a bedpan

20 a hospital gown

21 a call button

22 an orderly

23 a wheelchair

24 CPR / cardiopulmonary resuscitation

25 an emergency room

26 a paramedic / an EMT

27 a stretcher

28 stitches

29 an ambulance

Word Partnerships

an in-	patient
an out-	
a blood	test
	type
	donor
give	blood
donate	



Words in Action

1. Make three lists: *People in a Hospital*, *Places in a Hospital*, and *Things in a Hospital*.
2. What things would you see in a patient's room? What things would you see in an operating room?



Medical Center

Words in Context

During a **physical**, a doctor does several tests. She listens to the patient's heart and lungs with a **stethoscope**. She checks the patient's blood pressure with a **blood pressure monitor**. For patients over 40, the doctor may also give the patient an **EKG**.

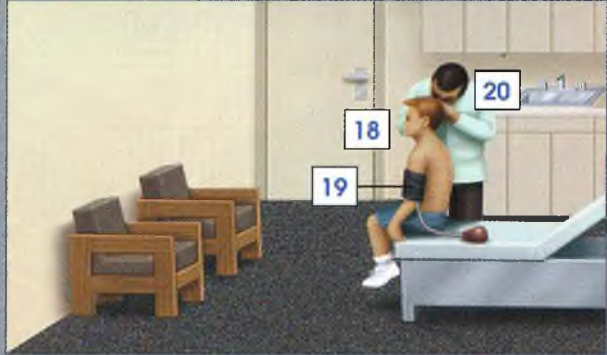
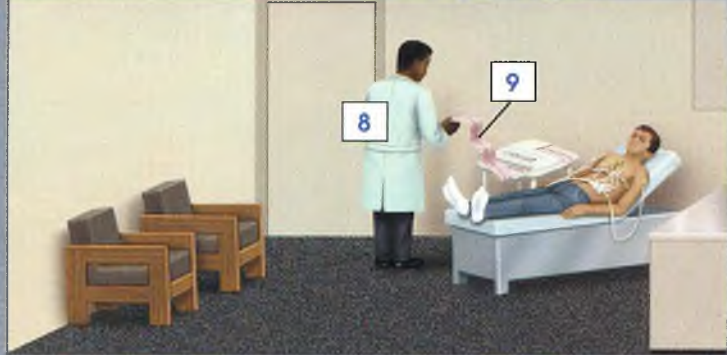
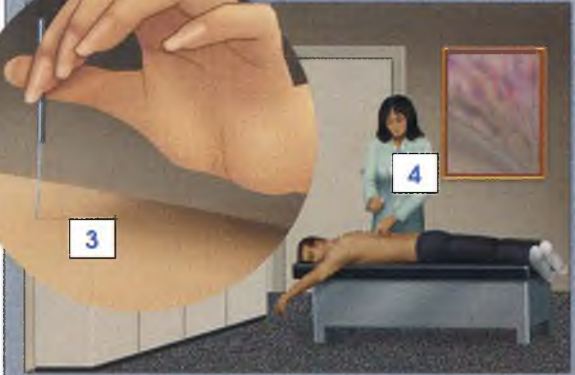

Word Partnerships

- | | |
|------------|---------------------------|
| hard | contacts / contact lenses |
| soft | |
| disposable | |
| a leg | cast |
| an arm | |
| an annual | physical |
| a dental | checkup |

- 1 a stethoscope
- 2 a medical chart
- 3 acupuncture
- 4 an acupuncturist
- 5 a psychologist
- 6 a waiting room
- 7 a pediatrician
- 8 a cardiologist
- 9 an EKG /
an electrocardiogram
- 10 an obstetrician
- 11 a pregnant woman
- 12 a sonogram /
an ultrasound
- 13 a sling
- 14 a crutch
- 15 a cast
- 16 a receptionist
- 17 an orthopedist
- 18 a physical (exam) /
a checkup
- 19 a blood pressure
monitor
- 20 a GP /
a general practitioner
- 21 an eye chart
- 22 a contact (lens)
- 23 an optometrist
- 24 (eye)glasses
- 25 a (dental) hygienist
- 26 a dentist
- 27 a filling
- 28 a tooth
- 29 braces
- 30 gums
- 31 a drill
- 32 a cavity

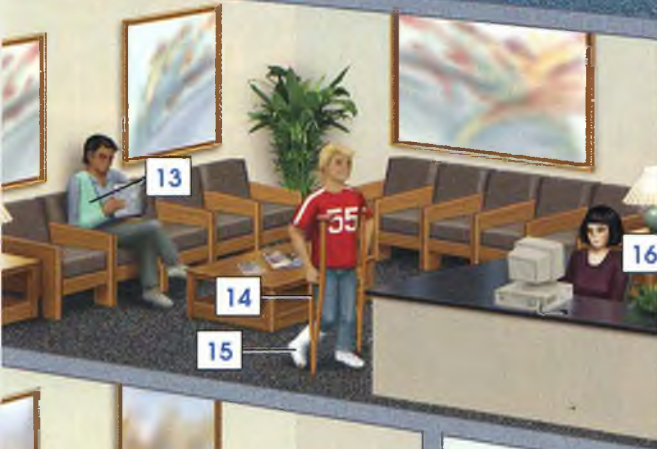

Words in Action

1. Work with a partner. Cover the word list. One person points to a person or object in the picture. The other says the word for the person or object. Take turns.
2. Work with a group. Make three lists. Who in your group has had a cast? Who has had a sling? Who has had crutches?



Pharmacy

Words in Context

Follow these steps to treat a cut.

- Press **gauze** on the cut. This will help stop the bleeding.
- Lift the cut above the heart.
- Clean the cut with soap and water. Then put **antibacterial ointment** on it.
- Cover the cut with a **sterile pad** and **sterile tape**.

Remember—accidents happen. Always keep a **first-aid kit** in your home.



1



2



3

1 a tablet

2 a capsule

3 a pill

4 prescription medicine

5 a pharmacist

6 over-the-counter medication

7 cough syrup

8 an antacid

9 (throat) lozenges

10 cough drops

11 an inhaler

12 a nasal (decongestant) spray

13 eyedrops

14 antihistamine

15 a prescription

16 a warning label

17 a cane

18 a knee brace

19 an elastic bandage

20 vitamins

21 a heating pad

22 hydrogen peroxide

Word Partnerships

take	medicine a vitamin a pill
use	eyedrops a thermometer a heating pad
fill	a prescription



- | | | | |
|----|---------------------|----|---|
| 23 | ○ first-aid kit | 29 | antibacterial ointment /
antibacterial cream |
| 24 | gauze | 30 | a thermometer |
| 25 | ○ sterile pad | 31 | tweezers |
| 26 | sterile tape | 32 | ○ humidifier |
| 27 | aspirin | 33 | an ice pack |
| 28 | an adhesive bandage | | |

Words in Action

- Which pharmacy items on the word list do you have in your home?
- Which pharmacy items are good for a cold? Which are good for a cut? Which are good for a sprain? Discuss with a partner.



Soap, Comb, and Floss

Words in Context

Did you know?

- The first **combs** were fish bones.
- Before **toothbrushes** and **toothpaste**, people cleaned their teeth with charcoal, lemon juice, or tobacco.
- In ancient Egypt, both men and women wore **makeup**.
- The Egyptians used red berries to make **rouge**.
- The Egyptians used bright red insects to make **lipstick**.

- 1 hairspray
- 2 shampoo
- 3 conditioner
- 4 hair gel
- 5 a curling iron
- 6 a blow dryer / a hair dryer
- 7 a barrette
- 8 a comb
- 9 rollers / curlers
- 10 a (hair)brush
- 11 nail polish
- 12 a nail clipper
- 13 dental floss
- 14 toothpaste
- 15 a toothbrush
- 16 shaving cream
- 17 aftershave

- 18 a razor
- 19 an electric shaver / an electric razor
- 20 deodorant
- 21 perfume
- 22 sunscreen
- 23 lotion
- 24 soap
- 25 tissues

Makeup

- 26 face powder
- 27 lipstick
- 28 blush / rouge
- 29 eye shadow
- 30 mascara
- 31 eyeliner





Verbs



32 wash



33 rinse



34 comb



35 (blow) dry



36 brush



37 cut



Word Partnerships

a disposable	razor
a dull	
nail polish	remover
hand	soap
face	
antibacterial	
hand	lotion
body	
put on	aftershave
wear	mascara
	lipstick

Words in Action

1. What things from the list do you use every day?
2. Work with a partner. One person pretends to use one of the items from the list. The other guesses what it is. Take turns.





Jobs 1

Words in Context

What kind of work is right for you? Do you like to work with your hands? You could be a **carpenter**, an **assembler**, or a **construction worker**. Do you want to help people? You could be a **babysitter**, a **home health aide**, or a **doctor**. Are you creative? You could be a **hairstylist**, a **florist**, or an **architect**. Are you good with numbers? You could be an **accountant** or an **engineer**.



1 an accountant

9 a delivery person

17 a barber

2 a dentist

10 a computer technician

18 an assembler

3 an artist

11 a janitor / a custodian

19 an architect

4 a cook

12 a doctor

20 a butcher

5 a hairstylist /
a hairdresser

13 a homemaker

21 a (home) health aide /
a (home) attendant

6 a construction worker

14 a florist

22 an engineer

7 a graphic artist

15 a housekeeper

23 a businessman /
a businesswoman

8 a gardener





3



4



5



6



2



12



7

Word Partnerships

a	part-time	job
	well-paid	
	blue-collar	
	white-collar	

look for	a job
apply for	
get	
lose	



13



14



21



22



23



24

24 a cashier

25 an actor

26 a carpenter

27 an electrician

28 a firefighter

29 a garment worker

30 a babysitter



27



28



29



30

Words in Action

1. Look at the list. What are the best five jobs to have? Why?
2. Which jobs are done in offices? Which are done in shops? Which are done outdoors? Make three lists.



Jobs 2

Words in Context

There are many **jobs** in my family. I'm a **reporter** for a newspaper. My sister is a **musician**. My brother likes to work with animals, so he is a **veterinarian**. My other brother travels a lot. He's a **truck driver**. Our parents are **teachers**. They taught us to love work.

1 a reporter

2 a manicurist

3 a lawyer

4 a soldier

5 a receptionist

6 a physical therapist

7 a locksmith

8 a security guard

9 a teacher /
an instructor

10 a mechanic

11 a police officer

12 a photographer

13 a stockbroker

14 a (house)painter

15 a plumber

16 a scientist

17 a taxi driver

18 a server

19 a nurse

20 a realtor

21 a salesperson

22 a tour guide

23 a pilot

24 a musician

25 a writer

26 a truck driver

27 a travel agent

28 a veterinarian / vet



Word Partnerships

a fashion photographer
 a wedding
 a registered nurse
 a school
 a commercial pilot
 a private
 a fighter



Words in Action

1. Look at the list. Which are the five most difficult jobs? Why? Which are the five easiest? Why?
2. Look at the list. Which people use vehicles in their jobs? What vehicles do they use? Which people use equipment in their jobs? What equipment do they use?



Working

Words in Context

Needed: Office Assistant

Can you answer phones, **take** messages, **schedule** appointments, and **file**? Can you **use** a computer and a fax machine? Can you **type** 50 words per minute? You may be the right person for this job. Call 555-9389 to schedule an appointment for an interview.

- 1 cook
- 2 examine
- 3 speak
- 4 arrest
- 5 open mail
- 6 load
- 7 deliver
- 8 type
- 9 take care of
- 10 act / perform
- 11 sing
- 12 take a message
- 13 hire
- 14 sell
- 15 repair / fix
- 16 plan



- 17 staple
- 18 manage
- 19 design
- 20 make copies
- 21 use a computer
- 22 call in sick
- 23 manufacture
- 24 file
- 25 drive
- 26 make a decision



Word Partnerships

attend	a weekly meeting	a company
take	a short break	a coffee
make	a tough decision	an easy
	a good	a bad

Words in Action

1. Which of the things on the list can you do?
2. Choose five verbs on the list. Look at the jobs on pages 146-149. Can you find one or more jobs that match the verb?



Farm

Words in Context

Jimmy Carter was the 39th president of the U.S. He grew up on a **farm** full of animals. There were **dogs**, **turkeys**, **horses**, and **cows** on the farm. Carter did many jobs around the farm. He **milked** the cows each day after school. He also **picked** cotton and peanuts in the **fields**.



- | | | |
|--------------------------------|----------------|--------------|
| 1 an orchard | 10 soil | 20 a rooster |
| 2 a silo | 11 a crop | 21 a goat |
| 3 a barn | 12 a scarecrow | 22 a horse |
| 4 a tractor | 13 hay | 23 a sheep |
| 5 a plow | 14 a farmer | 24 a donkey |
| 6 a farmworker /
a farmhand | 15 a farmhouse | 25 a pig |
| 7 a bull | 16 a dog | 26 a cow |
| 8 a vineyard | 17 a cat | 27 a turkey |
| 9 a field | 18 a rabbit | 28 a chicken |
| | 19 a goose | |

Verbs



29 plant



30 water



31 pick



32 milk



33 feed

2

3

5

4

6

7

22

21

23

24

25

26

27

28

Animal

dog
cat
chicken
pig
sheep
cow
goat

Baby Animal

puppy
kitten
chick
piglet
lamb
calf
kid

Words in Action

1. Study the word list for three minutes. Then close your book. Write down as many of the words as you can remember. Write each word under one of these categories: *People and animals on a farm, Things on a farm, Places on a farm.*
2. Choose a word and draw a picture of it on the board. The first classmate to guess the word gets a point and draws the next picture on the board.



Office

Words in Context

Offices are very different today than they were 100 years ago. Back then there were no **computers, fax machines, or photocopiers**. People used **typewriters** to write letters. However, some things are the same. Most offices still have **file cabinets** and use supplies like **staplers, paper clips, and rubber bands**.



JOHN LOPEZ
45 Laconer Street • Brooklyn, New York 11201 • (718) 355-0303

Executive Assistant

QUALIFICATIONS

- A highly organized and detail-oriented Executive Assistant providing skilful administrative support.
- Able to prioritize tasks and achieve goals.
- A self-motivated professional.
- Excellent research and writing skills.

Computer skills include: MS Word, PowerPoint, Excel

EXPERIENCE

KEMCORP, New York, N.Y.

- Executive Assistant to the CEO, 2003-present
- Coordinated conference calls.
- Created effective filing systems.
- Conducted exhaustive research, including quick indexing, filing and maintaining c-EO's calendar.
- Updated appointments with important clients and systems and procedures which...

- | | | |
|---------------------------------------|---|---------------------|
| 1 a typewriter | 12 a telephone | 26 sticky notes |
| 2 a binder | 13 letterhead | 27 staples |
| 3 a fax machine | 14 an appointment book /
a date book | 28 correction fluid |
| 4 a (photo)copier /
a copy machine | 15 a business card file | 29 a paper clip |
| 5 a (photo)copy | 16 a (paper) shredder | 30 a hole punch |
| 6 an office manager | 17 a resume | 31 a pad |
| 7 a desk | 18 a file cabinet | 32 a label |
| 8 a computer | 19 an office assistant /
a secretary | |
| 9 tape | 20 a (file) folder | |
| 10 a stapler | 21 an (electric) pencil
sharpener | |
| 11 a calculator | 22 a supply cabinet | |
| | 23 a thumbtack | |
| | 24 a rubber band | |
| | 25 glue | |

Word Partnerships

double sided	tape
packing	
hook up	a fax machine
turn on	a computer
turn off	



Words in Action

- Which items on the list do you have at home?
- Work with a partner. One student describes an office item. The other student guesses the item.
 - Student A: *You use this to add numbers.*
 - Student B: *A calculator.*



Factory

Words in Context

Making a chair is a process. There are many steps. The **designer** creates a design. **Parts** for the chair arrive at the **factory's loading dock**. Then **assembly line workers** put the chair together. It travels down a **conveyor belt** and gets a new part at each area. At the end of the assembly line, **packers** put the chair into a box. It goes into a **warehouse**. Then a **shipping clerk** sends it to a store near you!

- 1 a designer
- 2 a front office
- 3 an assembly line
- 4 a worker
- 5 a robot
- 6 a conveyor belt
- 7 a packer
- 8 a hard hat
- 9 a supervisor



30 biohazard



31 electrical hazard



32 explosive materials



33 flammable materials



34 poisonous materials



35 radioactive materials

- 10 a forklift
- 11 a time card
- 12 a time clock
- 13 parts
- 14 a machine operator
- 15 a warehouse
- 16 a shipping clerk
- 17 a fire extinguisher
- 18 a loading dock
- 19 a hand truck / a dolly
- 20 a hairnet
- 21 a safety visor
- 22 a respirator
- 23 safety goggles
- 24 earplugs
- 25 safety glasses
- 26 a particle mask
- 27 a safety vest
- 28 safety boots
- 29 safety earmuffs

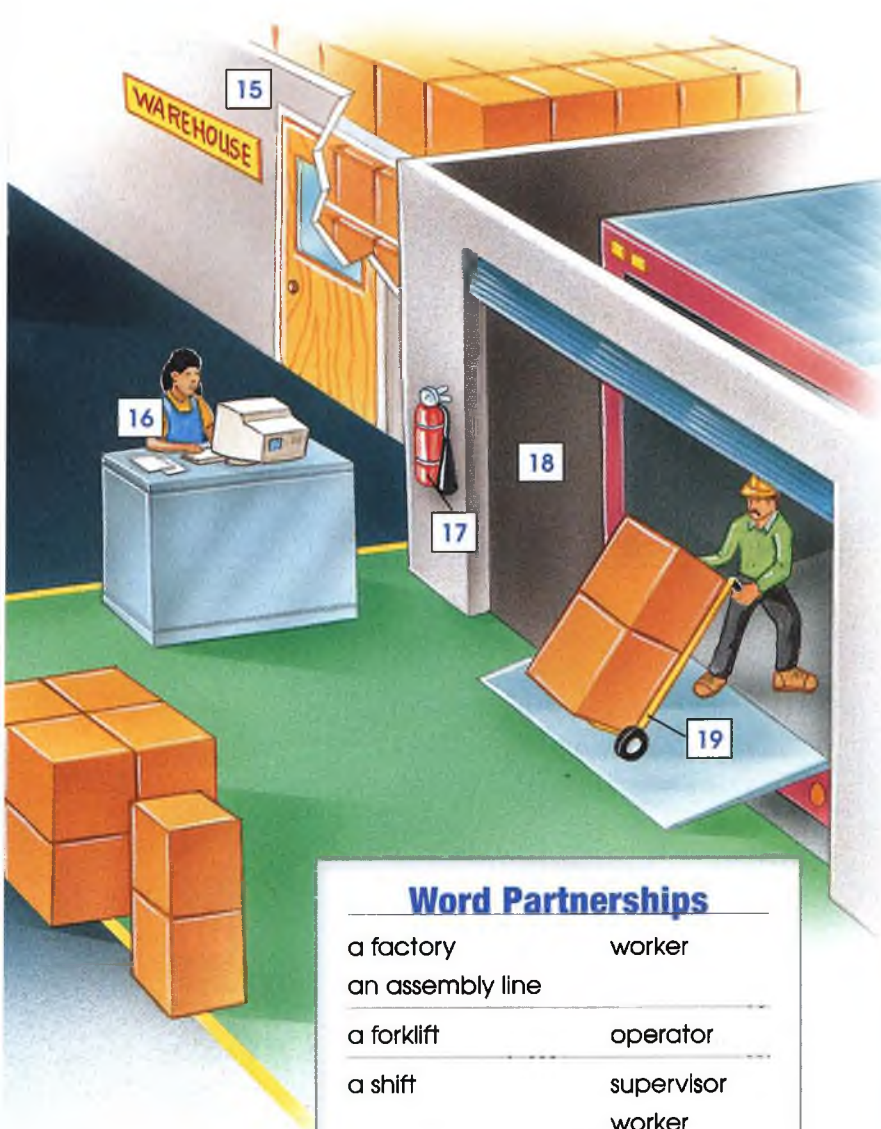
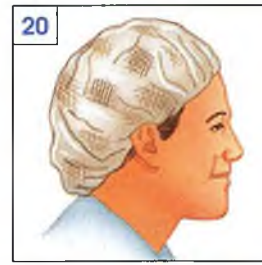

Word Partnerships

- | | |
|------------------|----------------------|
| a factory | worker |
| an assembly line | |
| a forklift | operator |
| a shift | supervisor
worker |
| punch | a time card |

Words in Action

1. Make a list of the people in this factory. Which job is the most interesting to you? Which is the least interesting? Why?
2. What part of the body do each of these pieces of safety equipment protect: earplugs, a hard hat, safety boots, safety goggles, a safety visor, safety earmuffs, safety glasses, a particle mask, a hairnet.



Hotel

Words in Context

There's a **hotel** in Sweden made completely of ice! You **check in** at the ice **lobby**. All the **rooms** and **suites** are made of ice, too. **Room service** brings you a hot drink in the morning. You can go to the **sauna** to warm up. Room rates are high, but the Ice Hotel is very popular. Be sure to **make** a reservation before you go!

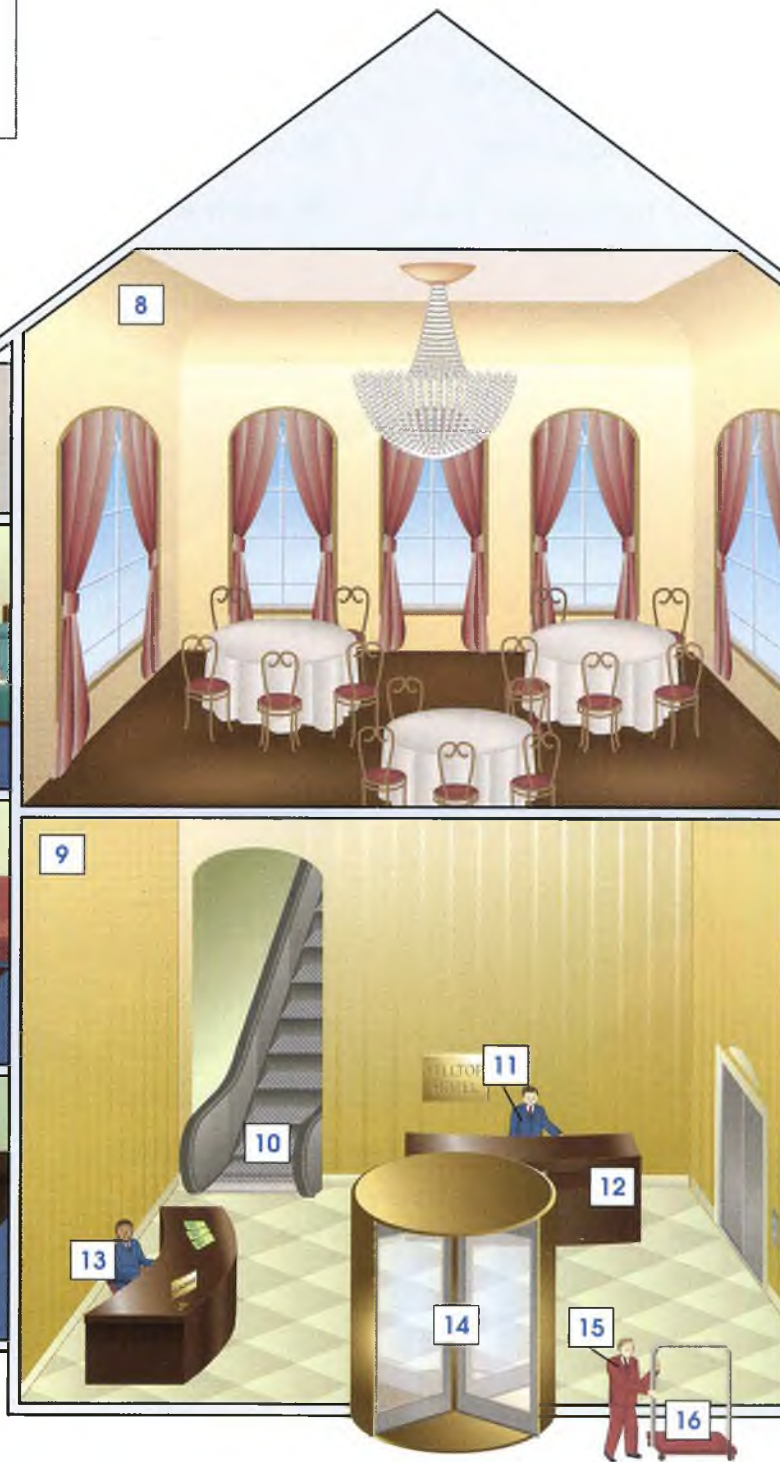
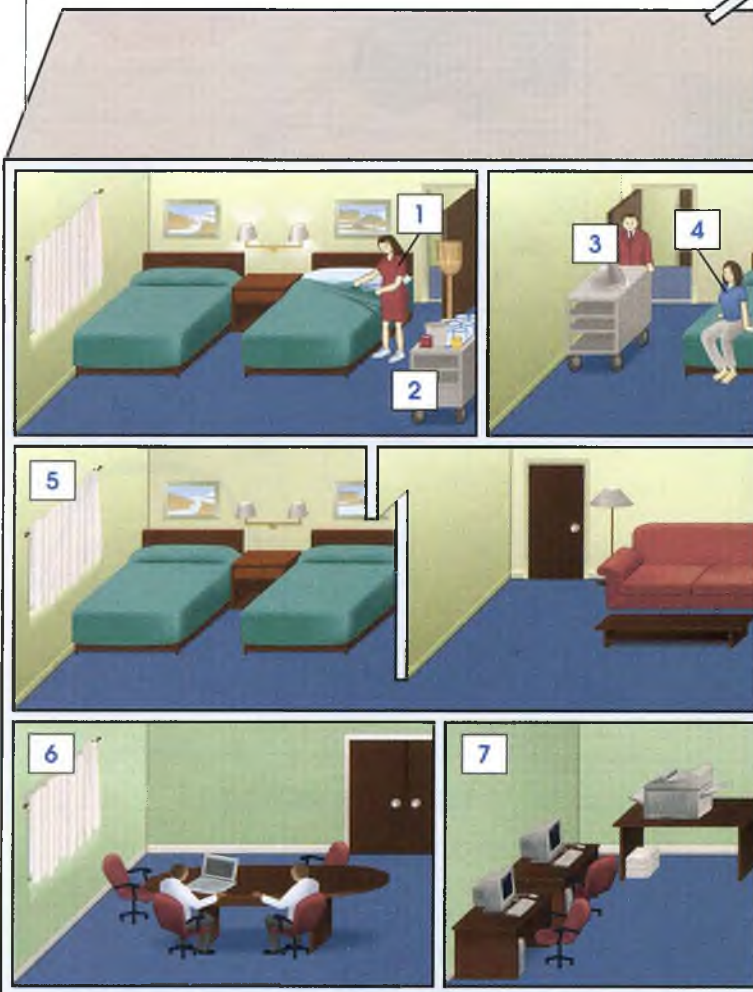

Verbs



24 make a reservation



25 check in



26 order room service



27 check out

- 1 a housekeeper
- 2 a housekeeping cart
- 3 room service
- 4 a (hotel) guest
- 5 a suite
- 6 a meeting room
- 7 a business center
- 8 a ballroom
- 9 a lobby
- 10 an escalator
- 11 a desk clerk
- 12 a registration desk
- 13 a concierge
- 14 a revolving door
- 15 a bellhop
- 16 a luggage cart
- 17 a (double) room
- 18 a (single) room
- 19 a fitness center
- 20 a sauna
- 21 a (swimming) pool
- 22 a gift shop
- 23 valet parking

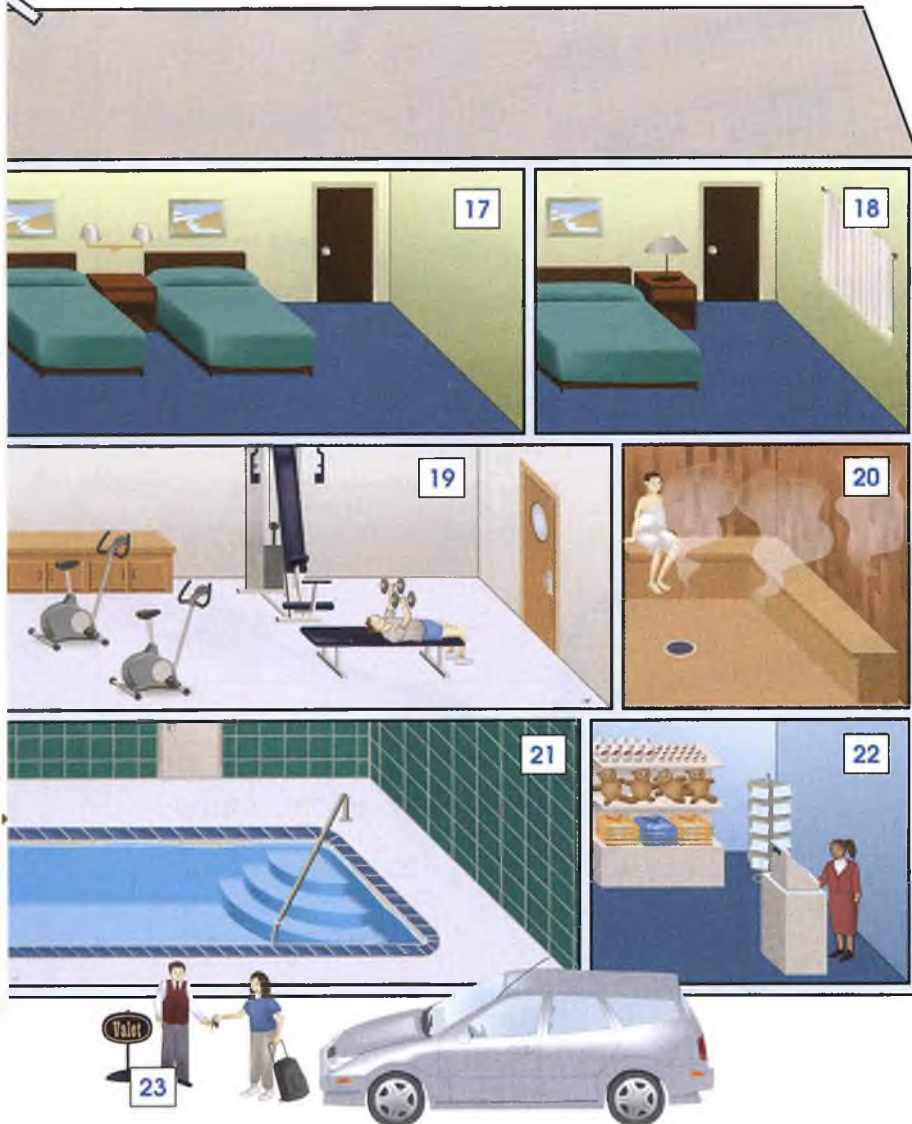

Word Partnerships

- | | |
|------------|-----------------|
| a luxury | hotel |
| a budget | |
| room | rates |
| an indoor | (swimming) pool |
| an outdoor | |
| a heated | |

Words in Action

1. Make three lists: *People in a Hotel*, *Places in a Hotel*, and *Things in a Hotel*.
2. Role-play with a partner. One of you is the desk clerk at a hotel. The other is calling with questions about the hotel.
 - Student A: *How much is a double room?*
 - Student B: *It's \$50 a night for a double.*
 - Student A: *Is there a swimming pool?*



Tools and Supplies 1

Words in Context

I go to hardware stores a lot because I work in construction. I keep my **wrench**, my **hammer**, and my **screwdriver** in my **tool belt**. Those are the **tools** I use the most.



- | | | | |
|-------------------|------------------|------------------|----------------------|
| 1 a utility knife | 7 a file | 13 a vise | 19 electrical tape |
| 2 a C-clamp | 8 a caulking gun | 14 a chisel | 20 an extension cord |
| 3 a sledgehammer | 9 a hammer | 15 pliers | 21 wire |
| 4 a shovel | 10 a wrench | 16 a level | 22 a lightbulb |
| 5 an ax | 11 a hacksaw | 17 a ruler | 23 a wire stripper |
| 6 a handsaw | 12 a tool belt | 18 a screwdriver | 24 (pipe) fittings |

Electrical



Plumbing



Power Tools



- 25 a pipe wrench
- 26 a pipe
- 27 a router
- 28 a drill
- 29 a drill bit
- 30 a blade
- 31 a circular saw
- 32 a power sander

Word Partnerships

- | | |
|-------------|-------------|
| a tool | bench |
| | box |
| a Phillips | screwdriver |
| a flathead | |
| an electric | drill |
| a cordless | |

Words in Action

1. Which items on the list have you used? What job did you do with each item?
2. Which tools would you use to:
 - build a bookcase?
 - wire a house?
 - install a sink?



Tools and Supplies 2

Words in Context

How to Hang a Picture on a Wall

- With a **tape measure** or ruler, measure 66 to 68 **inches** above the floor.
- Put a small piece of **masking tape** on the wall.
- Put a **nail** through a picture **hook**, and pound it in through the masking tape.
- Hang your picture.

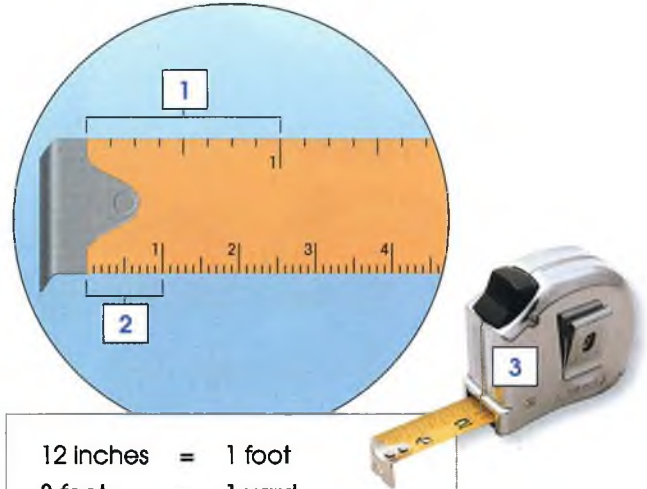

12 inches = 1 foot
 3 feet = 1 yard

1 inch = 2.54 centimeters
 1 foot = 30.5 centimeters

1 mile = 1.6 kilometers

Building Material

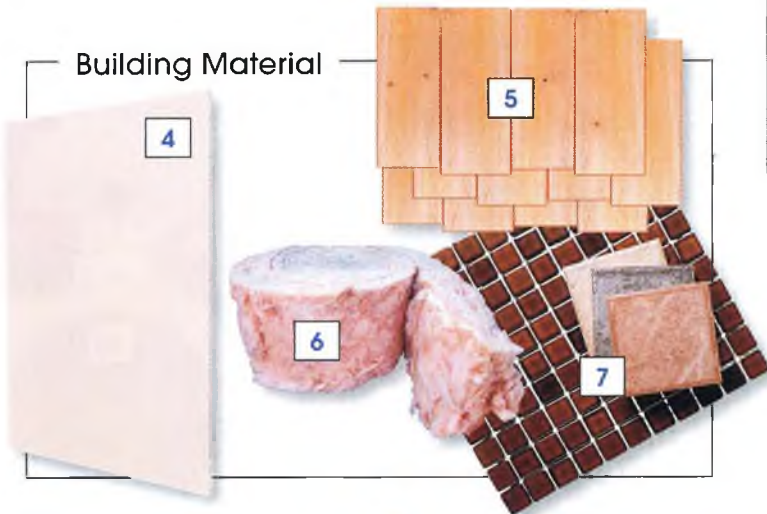

Paint Supplies



Hardware



Lumber / Wood



Word Partnerships

a hardware store	section
a sheet of plywood	drywall
spray latex acrylic	paint



- | | | |
|------------------|---------------------|-----------------|
| 1 an inch | 14 paint | 27 a hook |
| 2 a centimeter | 15 a paint tray | 28 plywood |
| 3 a tape measure | 16 a (paint) roller | 29 molding |
| 4 drywall | 17 steel wool | 30 board lumber |
| 5 shingles | 18 an anchor | 31 duct tape |
| 6 insulation | 19 an eye hook | 32 a chain |
| 7 tile | 20 a nail | 33 a battery |
| 8 a flashlight | 21 a bolt | 34 a padlock |
| 9 a rope | 22 a screw | |
| 10 a paintbrush | 23 a nut | |
| 11 a scraper | 24 a wing nut | |
| 12 sandpaper | 25 a hinge | |
| 13 masking tape | 26 a washer | |

Words in Action

1. Name one of the items on the list, then think of as many uses for the item as you can.
2. Imagine you need to paint some windows in an old house. Which items will you need to prepare the windows and paint them?





Drill, Sand, Paint

Words in Context

In 1980, Edouard Arsenault, a Canadian fisherman, began to make buildings with old glass bottles. He used thousands of bottles. He **mixed** cement. Then, instead of **laying** bricks, he laid rows of bottles in the wet cement. After he **put up** the glass walls, he **installed** skylights. Many people visit these buildings each year.

Word Partnerships

paint	a wall
	a room
	a house
install	a phone line
	a water heater
shovel	gravel
	snow



1 put up drywall

2 plaster a wall

3 paint a wall

4 drill a hole

5 lay bricks

6 pull a rope

7 pour concrete

8 wire a house

9 hammer a nail

10 saw wood

11 measure

12 weld

13 install a window

14 climb a ladder

15 operate a backhoe

16 tear down a wall

17 read blueprints

18 carry a bag

19 shovel sand

20 push a wheelbarrow

21 cut a pipe

22 dig a trench

23 plane wood

24 glue wood

25 sand wood



Words in Action

1. Check off the things on the list you have done.
2. Pretend to be doing one of the actions on the word list. Your partner will guess what you are doing.



Weather

Words in Context

Today's **weather**:

Don't expect **sunshine** today. The morning will be **cold** and **windy** with a good chance of **rain**. This afternoon the temperature will drop, and we will see five to seven inches of **snow** tonight!

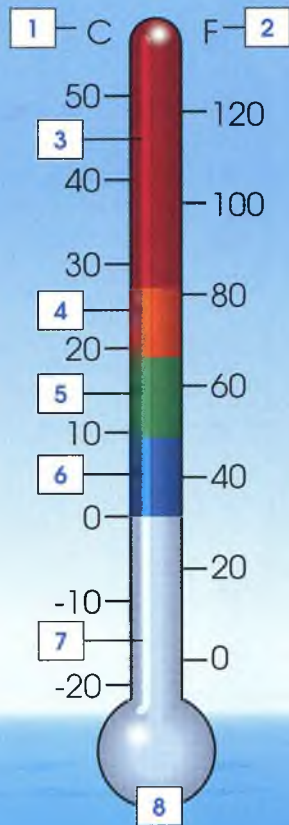

- | | | |
|-----------------|--------------|----------------|
| 1 Celsius | 9 the sun | 17 wind |
| 2 Fahrenheit | 10 the sky | 18 hail |
| 3 hot | 11 a rainbow | 19 snow |
| 4 warm | 12 a cloud | 20 rain |
| 5 cool | 13 sunshine | 21 a hailstone |
| 6 cold | 14 a storm | 22 a snowflake |
| 7 freezing | 15 lightning | 23 a raindrop |
| 8 a thermometer | 16 fog | 24 ice |



25 It's sunny.



26 It's cloudy.



27 It's windy.



28 It's snowing.



29 It's foggy.



30 It's raining.

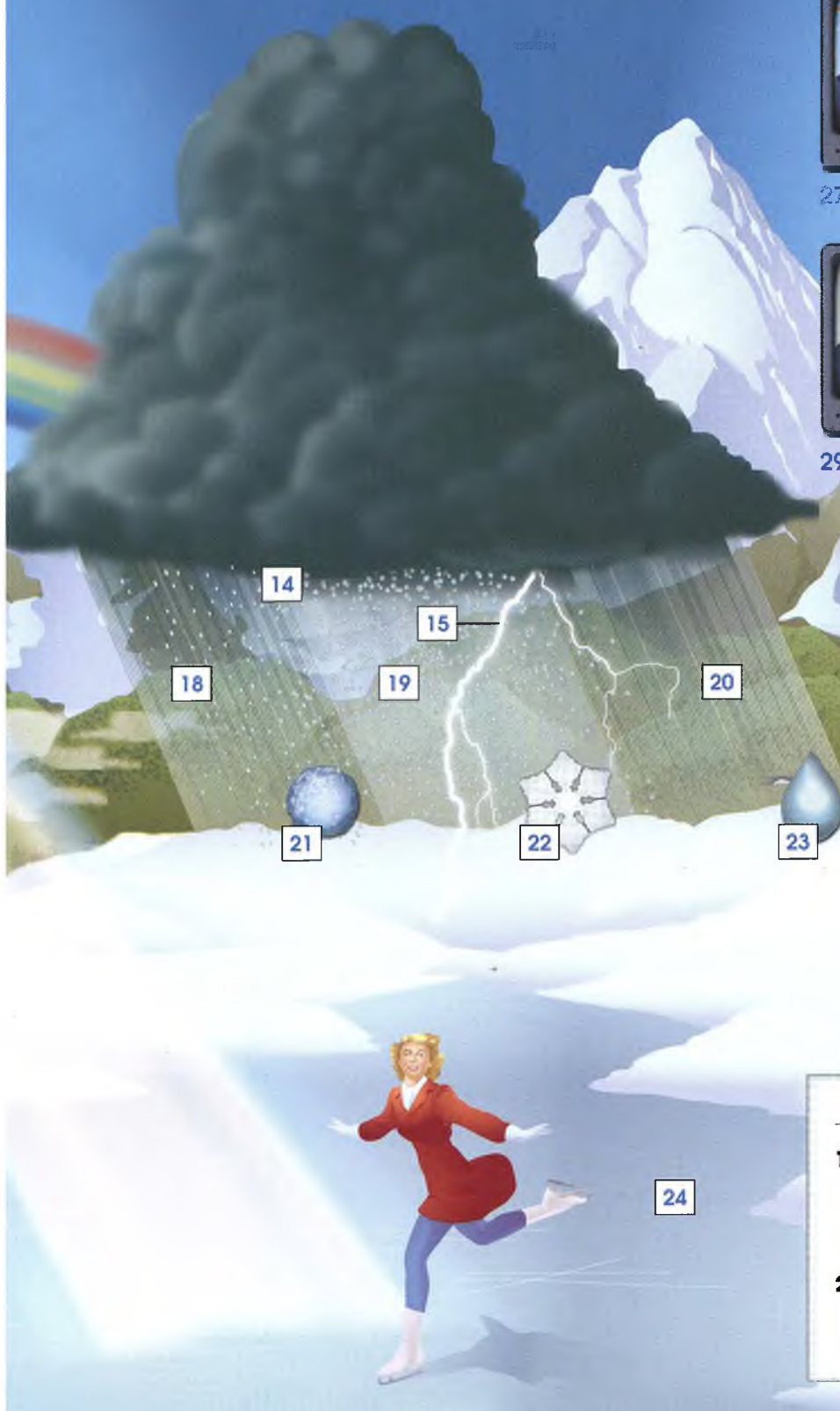

Word Partnerships

25	degrees	Celsius
77		Fahrenheit
a cold	wind	
a bitter		
a heavy	rain	
a light		
a blue	sky	
a gray		
a cloudless		

Words in Action

- Describe the weather today. Then describe yesterday's weather.
 - It's rainy and cool today. Yesterday was sunny and warm.*
- What is your favorite kind of weather? Why?
 - I like sunny weather because I can go to the beach.*



The Earth's Surface

Words in Context

The land changes across the United States. There are **mountains** in the West, **hills** in the East, and wide **plains** in between. There are **deserts**, **canyons**, miles of coastline, and thousands of **lakes**.

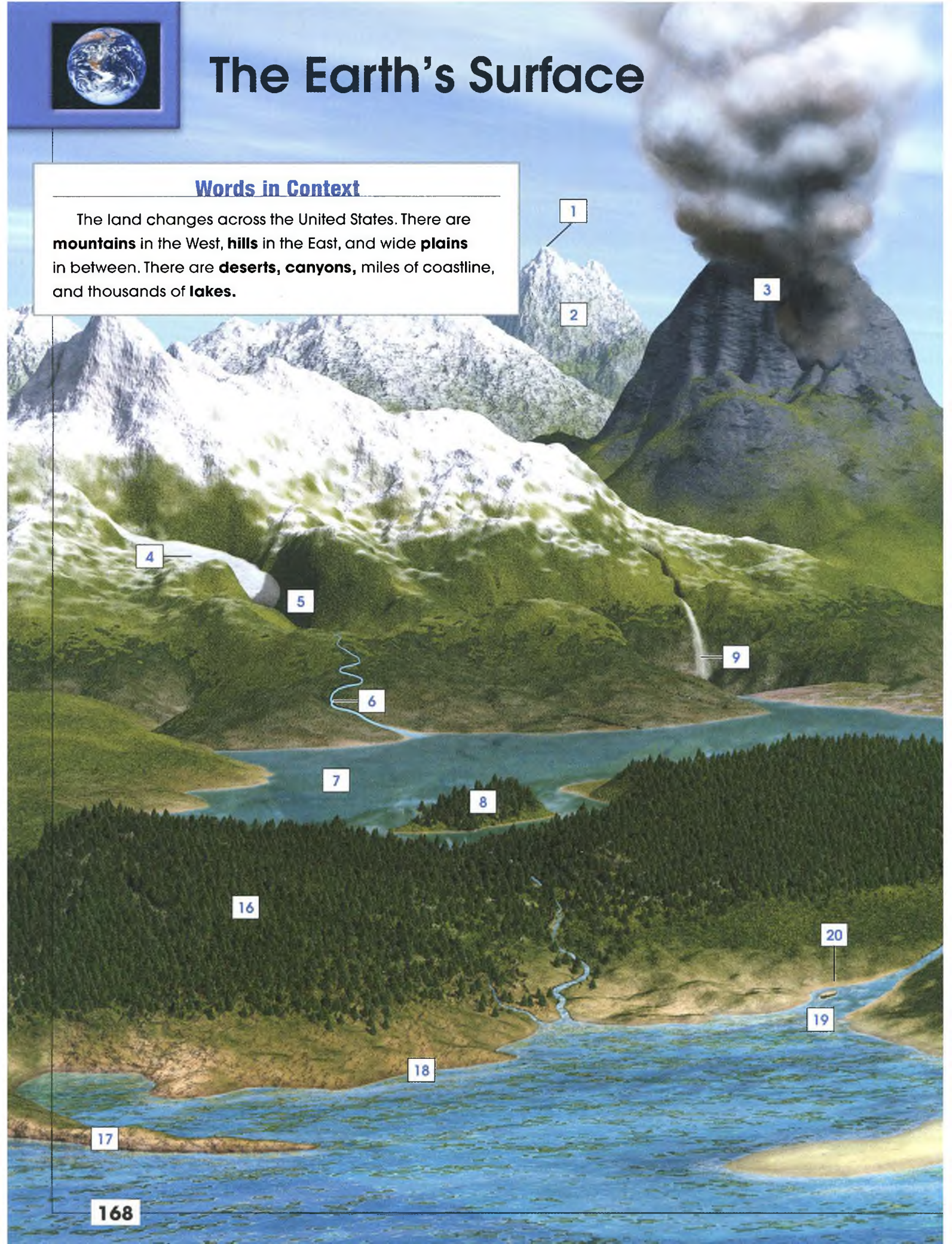

1 a peak

2 a mountain

3 a volcano

4 a glacier

5 a valley

6 a stream

7 a lake

8 an island

9 a waterfall

10 a crater

11 a desert

12 a plateau

13 a canyon

14 a cave

15 a mesa

16 a forest

17 a peninsula

18 a shore

19 the mouth of the river

20 a riverbank

21 a river

22 a hill

23 a beach

24 an ocean

25 a bay

26 plains

27 a cliff

Word Partnerships

a sandy beach

a rocky

a deep river

a shallow

a mountain peak

range

an active volcano

a steep hill

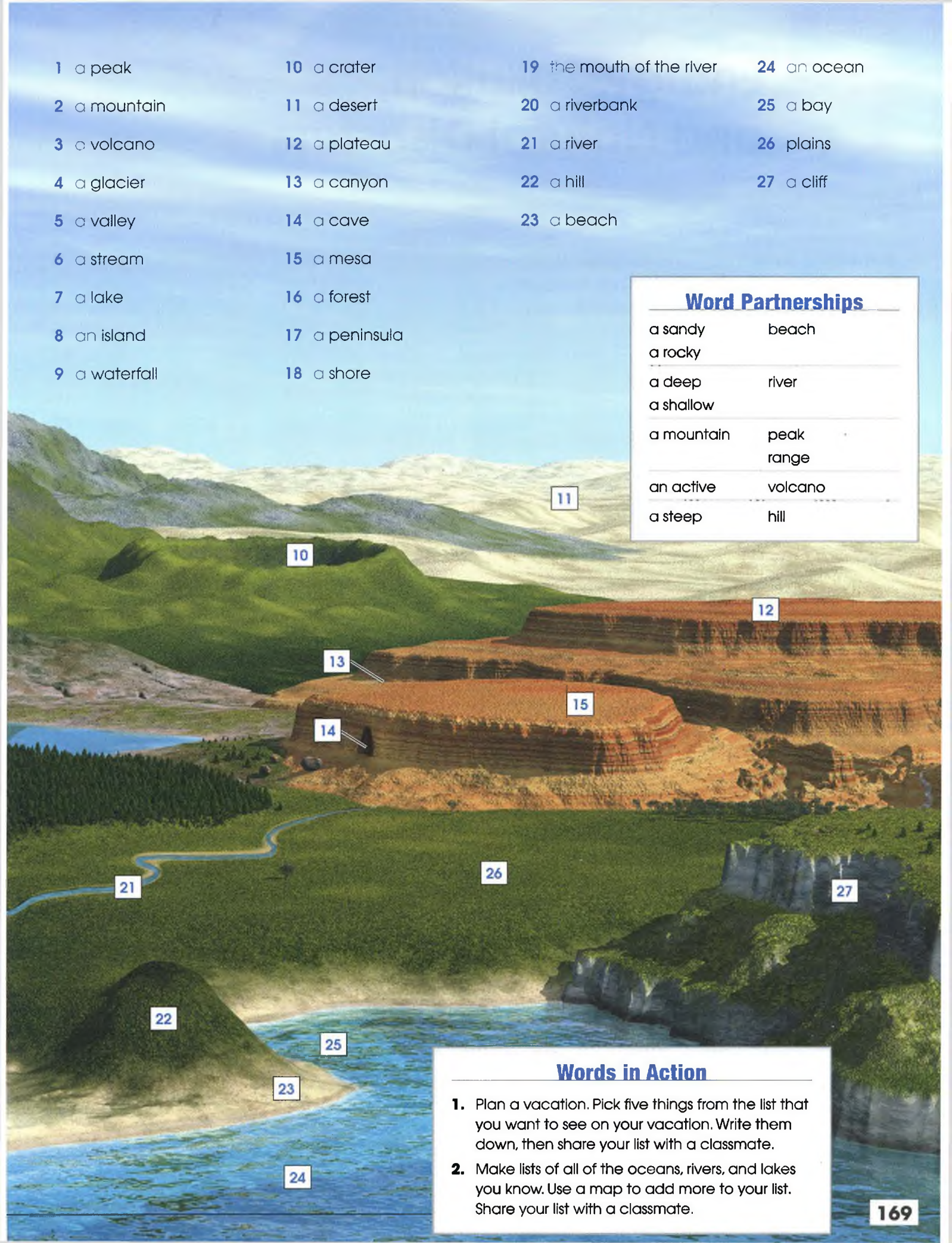

11

10

12

13

15

14

26

21

27

22

25

23

24

Words in Action

1. Plan a vacation. Pick five things from the list that you want to see on your vacation. Write them down, then share your list with a classmate.
2. Make lists of all of the oceans, rivers, and lakes you know. Use a map to add more to your list. Share your list with a classmate.



Energy, Pollution, and Natural Disasters

Words in Context

Automobile exhaust creates **air pollution**. Air pollution can turn into **acid rain**. Acid rain kills plants and animals. Some new cars run on **solar energy**. These cars don't create air pollution.



Natural Disasters

- 1 a forest fire
- 2 a blizzard
- 3 a drought
- 4 a famine
- 5 an earthquake
- 6 a flood
- 7 an avalanche
- 8 a hurricane

- 9 a mudslide
- 10 a tsunami / a tidal wave
- 11 a tornado
- 12 a volcanic eruption

Pollution

- 13 air pollution / smog
- 14 acid rain
- 15 an oil spill
- 16 pesticide poisoning

- 17 radiation
- 18 hazardous waste
- 19 water pollution
- 20 automobile exhaust
- 21 litter

Energy

- 22 natural gas
- 23 oil / petroleum
- 24 wind
- 25 geothermal energy
- 26 coal
- 27 solar energy
- 28 nuclear energy
- 29 hydroelectric power

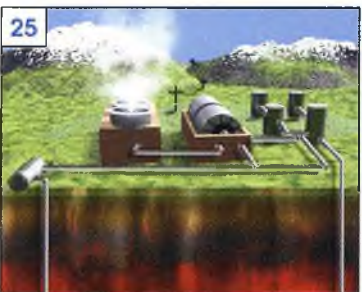
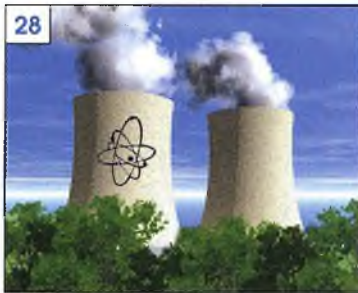
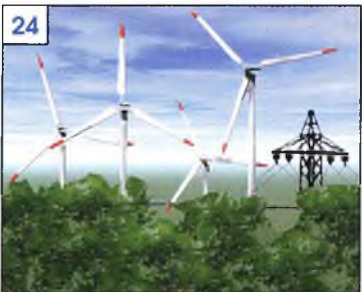

Word Partnerships

a long	drought
a severe	
a flash	flood
a minor	earthquake
a major	
environmental	disasters
	pollution

Words in Action

1. Work with a group. Choose two or three natural disasters. In what parts of the world has each disaster happened? Make a list for each disaster.
2. Which kind of energy source do you use to heat your home? Which do you use to cook? Which do you use to dry your clothes? Discuss with a group.



The United States and Canada

Words in Context

There are fifty states in the **United States**. The capital is **Washington, D.C.** The U.S. city with the most people is **New York City**. **Canada** is much larger than the U.S., but it has far fewer people. The capital of Canada is **Ottawa** and the city with the most people is **Toronto**.

Regions of Canada

- 1 Northern Canada
- 2 British Columbia
- 3 the Prairie Provinces
- 4 Ontario
- 5 Quebec
- 6 the Atlantic Provinces

Regions of the United States

- 7 the West Coast
- 8 the Rocky Mountain States
- 9 the Midwest
- 10 the Mid-Atlantic States
- 11 New England
- 12 the Southwest
- 13 the South



ARCTIC OCEAN

Yukon

Whitehorse

Northwest Territories

Yellowknife

Nunavut

Iqaluit

2

British Columbia

3

Alberta

Saskatchewan

Manitoba

4

Ontario

5

Québec

6

Newfoundland & Labrador

St. John's

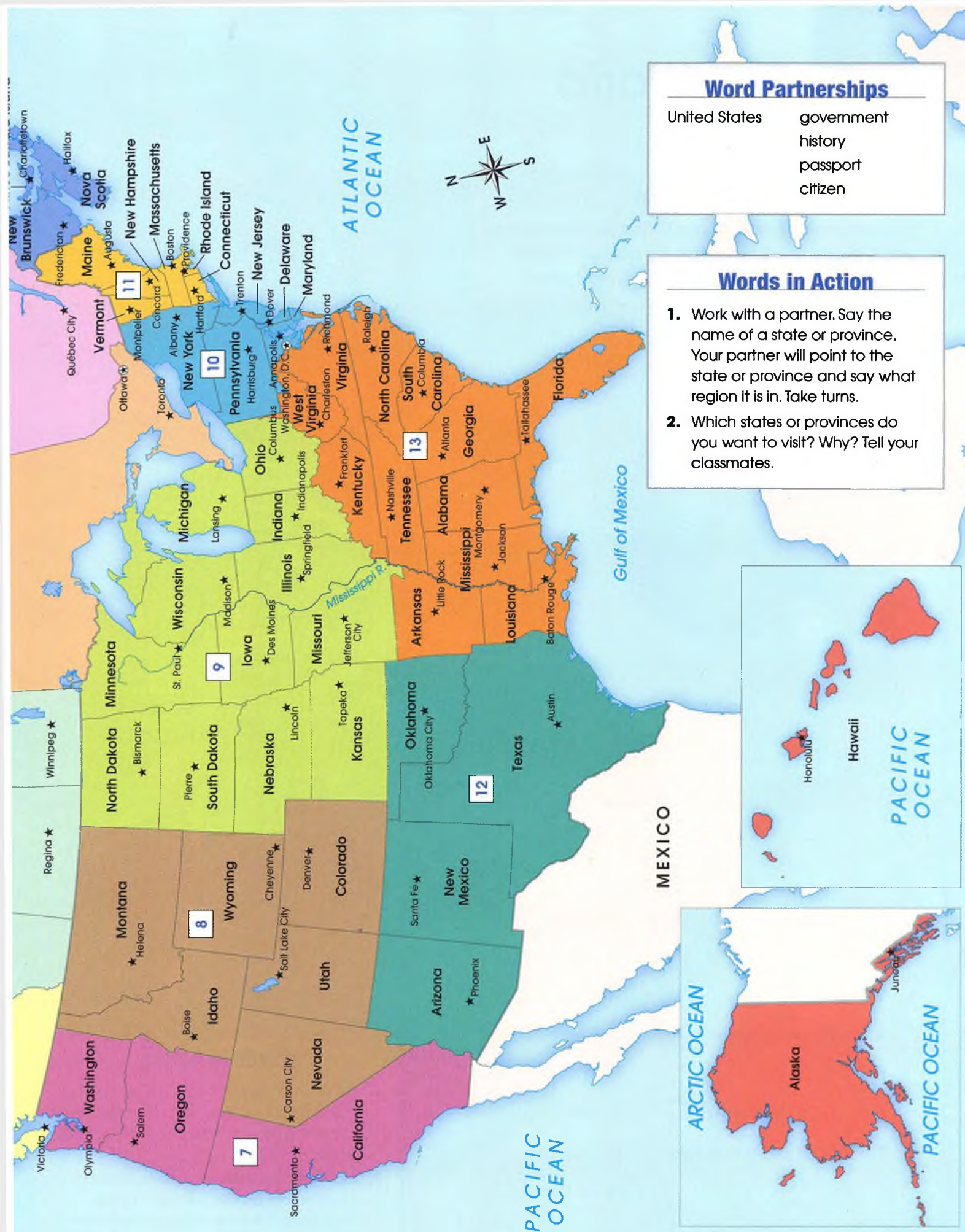

Word Partnerships

United States	government
	history
	passport
	citizen

Words in Action

1. Work with a partner. Say the name of a state or province. Your partner will point to the state or province and say what region it is in. Take turns.
2. Which states or provinces do you want to visit? Why? Tell your classmates.



The World

Words in Context

There are seven **continents** and almost 200 countries in the **world**. **Russia** and **Canada** are the biggest countries. **China** and **India** are the countries with the most people.

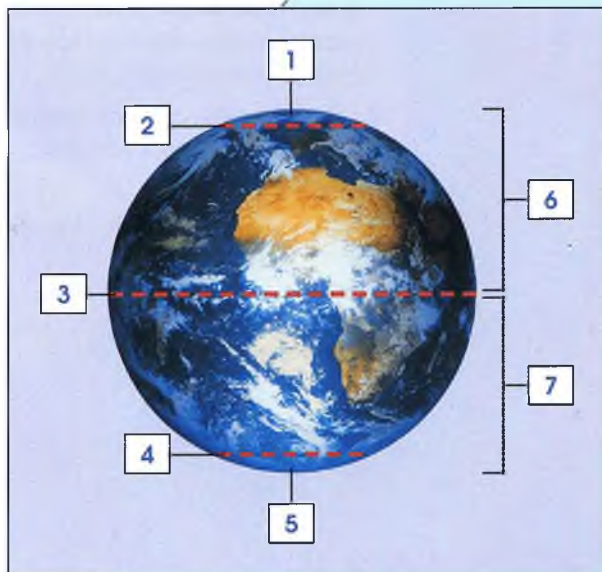

- 1 the North Pole
- 2 the Arctic Circle
- 3 the Equator
- 4 the Antarctic Circle
- 5 the South Pole
- 6 the Northern Hemisphere
- 7 the Southern Hemisphere

Continents

- 8 North America
- 9 South America
- 10 Europe
- 11 Asia
- 12 Africa
- 13 Australia
- 14 Antarctica



Words in Action

1. Go around the room saying the name of a country for each letter of the alphabet. (There are no countries that start with the letters w or x.)
2. Work with a partner. Say the name of a country. Your partner will point to the country on the map and say the name of the continent it is in. Take turns.

Word Partnerships

a world	map
	record
world	peace
on	the equator
above	
below	



ARCTIC OCEAN

Greenland (Den.)

ICELAND

10

EUROPE

11

ASIA

12

AFRICA

13

AUSTRALIA

14

ANTARCTICA

PACIFIC OCEAN

ATLANTIC OCEAN

INDIAN OCEAN

ATLANTIC OCEAN



The Universe

Words in Context

The first **satellite** went into **space** in 1957. The first human went into space in 1961. In 1969 an **astronaut** walked on the **moon** for the first time. Today some astronauts even live on a **space station** for a few months at a time!

1 a space station

2 a constellation

3 a star

4 a rocket

5 an eclipse

6 an orbit

7 a galaxy

8 an observatory

9 a telescope

10 an astronomer

11 space

12 the moon

13 a satellite

14 an astronaut

15 Earth's atmosphere

16 a meteor

17 a space shuttle

18 the sun

19 a comet

The Planets

20 Pluto

21 Neptune

22 Uranus

23 Saturn

24 Jupiter

25 Mars

26 Earth

27 Venus

28 Mercury

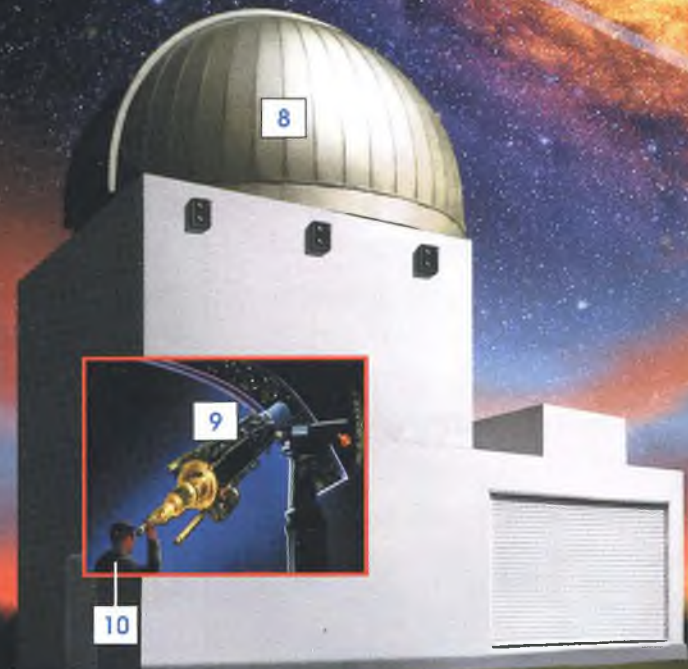
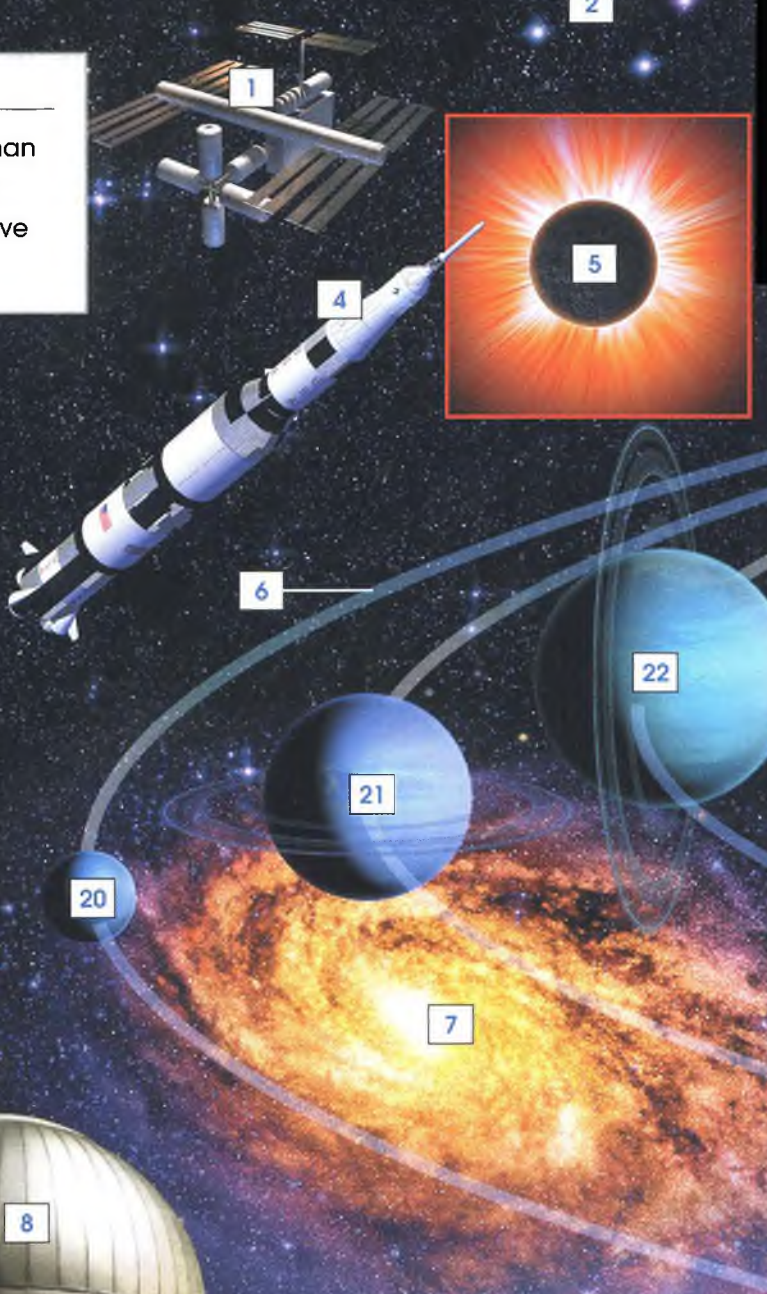



29 a new moon



30 a crescent moon



31 a quarter moon



32 a full moon

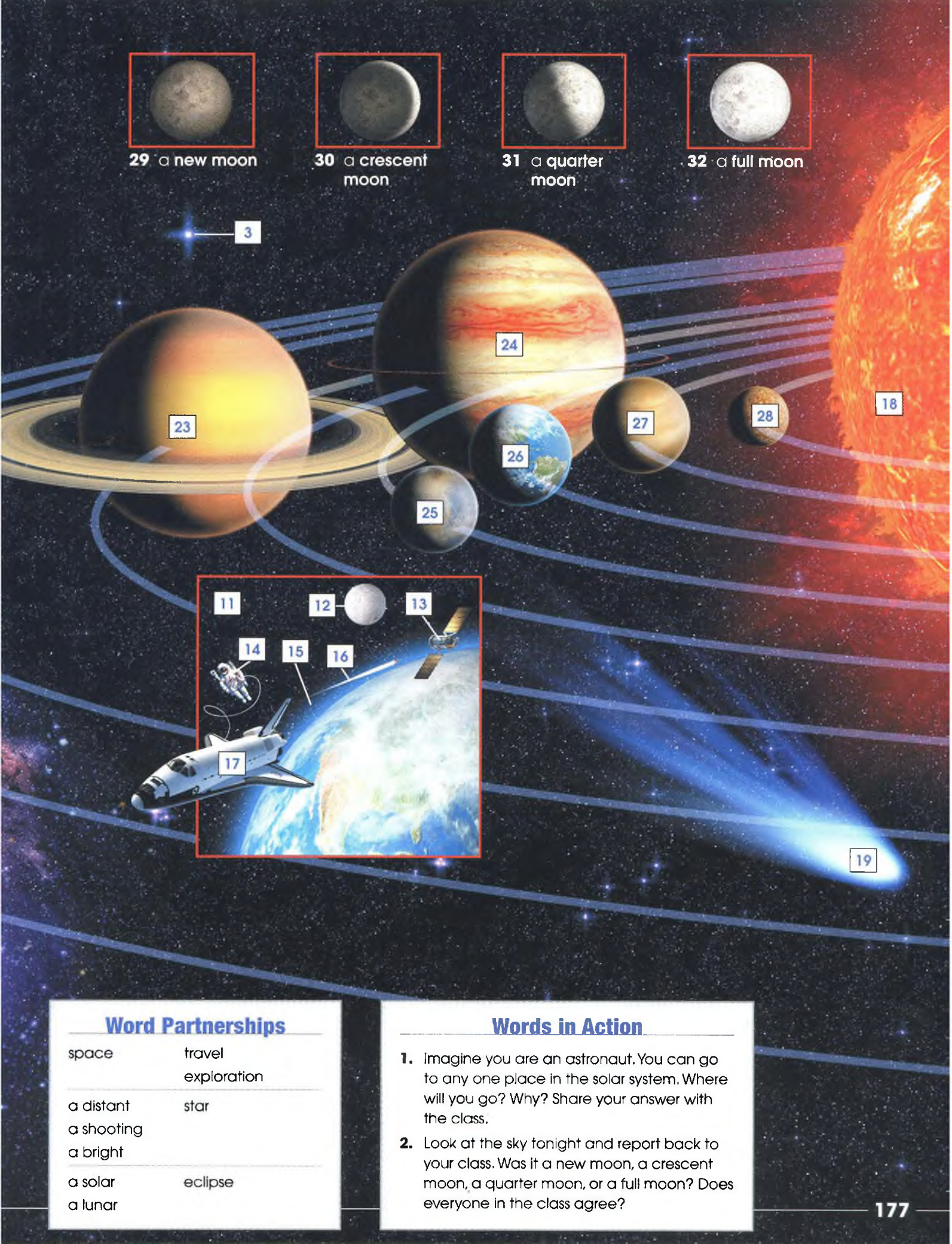

Word Partnerships

space	travel
	exploration
a distant	star
a shooting	
a bright	
a solar	eclipse
a lunar	

Words in Action

1. Imagine you are an astronaut. You can go to any one place in the solar system. Where will you go? Why? Share your answer with the class.
2. Look at the sky tonight and report back to your class. Was it a new moon, a crescent moon, a quarter moon, or a full moon? Does everyone in the class agree?



Garden

Words in Context

There are 350,000 kinds of plants. Most plants grow from a **seed**. First **roots** grow from seeds, then **stems**, and then **leaves**. In **pine trees**, seeds come from the **pinecones**. In **lilacs**, **poppies**, **sunflowers**, and many other plants, seeds come from inside the **flowers**.



1

2

3

4

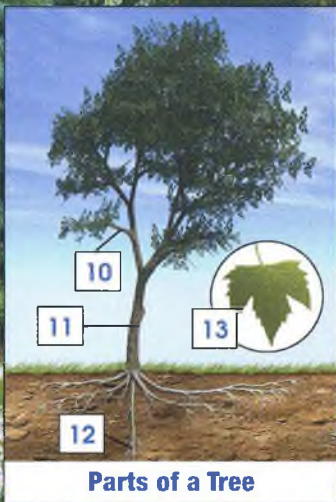

Parts of a Tree

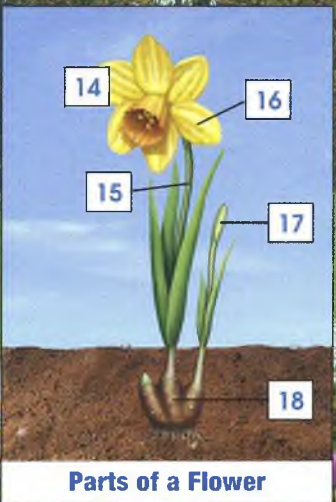

Parts of a Flower

19

20

21

22

23

25

26





- 1 a pine (tree)
- 2 a willow (tree)
- 3 a birch (tree)
- 4 a maple (tree)
- 5 an oak (tree)
- 6 an elm (tree)
- 7 a lilac bush
- 8 a greenhouse
- 9 a pinecone
- 10 a branch
- 11 a trunk
- 12 roots
- 13 a leaf
- 14 a flower
- 15 a stem
- 16 a petal
- 17 a bud
- 18 a bulb
- 19 irises
- 20 lilies
- 21 chrysanthemums
- 22 daffodils
- 23 violets
- 24 a seed
- 25 tulips
- 26 marigolds
- 27 ivy
- 28 roses
- 29 sunflowers
- 30 geraniums
- 31 daisies
- 32 poppies

Word Partnerships

a shade	tree
an evergreen	
send	flowers
give	
get / receive	
a bouquet of	roses
a dozen	
long-stem	

Words in Action

1. Which of the flowers and trees grow in your area? Make a list with your class.
2. Describe a flower or tree to a partner. Your partner will guess the flower or tree. Take turns.
 - Student A: *It has a yellow center and white petals. It doesn't really have a smell.*
 - Student B: *It's a daisy.*



Desert

Words in Context

Fourteen percent of the earth's surface is **desert**. Deserts contain mostly sand and **rocks**. They get very little rain. Many animals and **insects**, like **camels**, **lizards**, **snakes**, **ants**, and **spiders**, live in the desert. The largest desert in the world is the Sahara Desert in North Africa. It has an area of about 900 million square kilometers.



Word Partnerships

- a red ant
- a black
- a fire
- a carpenter
- a swarm of ants
- flies
- a poisonous snake
- spider



1 a hawk

2 an owl

3 a boulder

4 a coyote

5 a mountain lion

6 a sand dune

7 a palm tree

8 a camel

9 a vulture

10 a lizard

11 a rock

12 a tortoise

13 a rat

14 a snake

15 an oasis

16 a cactus

17 a pebble

Insects / Bugs

18 a spider

19 a grasshopper

20 a fly

21 a moth

22 a cricket

23 a scorpion

24 an ant



Words in Action

1. One student chooses a word from the word list. The other students ask "Yes / No" questions to gather information and try to guess the word.
 - Student A: *Is it an animal?*
Student B: *No.*
 - Student C: *Is it an insect?*
Student B: *Yes.*
 - Student D: *Does it have wings?*
Student B: *Yes.*
 - Student D: *Is it a fly?*
Student B: *Yes!*
2. Imagine you are taking a trip to the desert. What things do you want to see? Discuss this with your class.



Rain Forest

Words in Context

Many plants and animals live in **rain forests**. Colorful **parrots** and playful **monkeys** live there. Beautiful **orchids** and long **vines** grow there. At night, **tigers** and **panthers** hunt in the rain forest.

- | | |
|------------------|------------------|
| 1 a parakeet | 14 an aardvark |
| 2 a vine | 15 a flamingo |
| 3 a chimpanzee | 16 a fern |
| 4 a bat | 17 a panther |
| 5 a parrot | 18 an alligator |
| 6 a monkey | 19 a crocodile |
| 7 a gorilla | 20 a caterpillar |
| 8 a peacock | 21 a butterfly |
| 9 a tiger | 22 a snail |
| 10 a hummingbird | 23 a wasp |
| 11 an orchid | 24 a beetle |
| 12 a frog | 25 a tarantula |
| 13 an orangutan | |

Word Partnerships

- | | |
|---------|-------|
| frogs | hop |
| wasps | sting |
| tigers | leap |
| monkeys | swing |

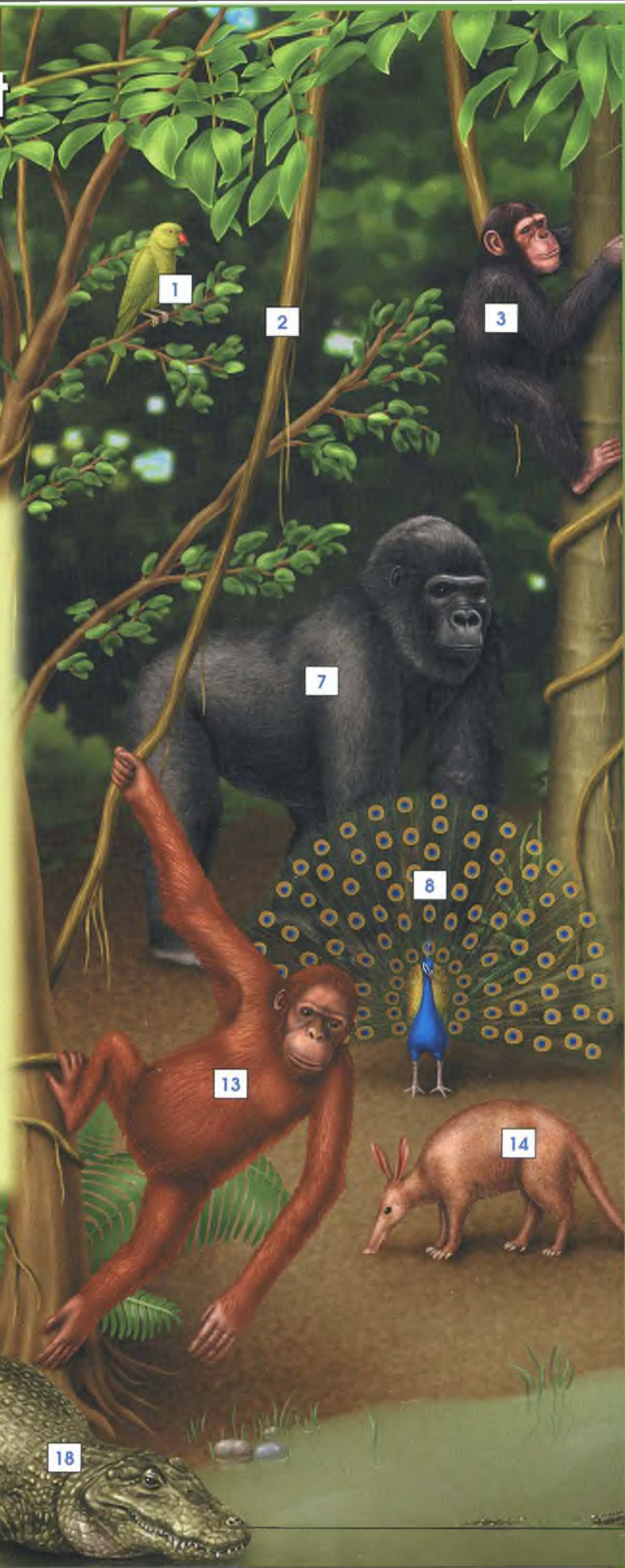



Verbs



26 swing



27 hop



28 hang



Words in Action

1. Work with a partner. Put the words into groups of plants, animals, and insects.
2. Choose one of the animals on the list that makes a noise. Make that animal's noise. Your partner will guess the animal. Take turns.



Grasslands



Words in Context

Animals in the **grasslands** have different sources of food. **Giraffes** and **elephants** graze on the tallest trees. **Buffalo** and **gazelles** graze on grasses. The large cats, like **lions**, **leopards**, and **cheetahs**, feed on other animals.

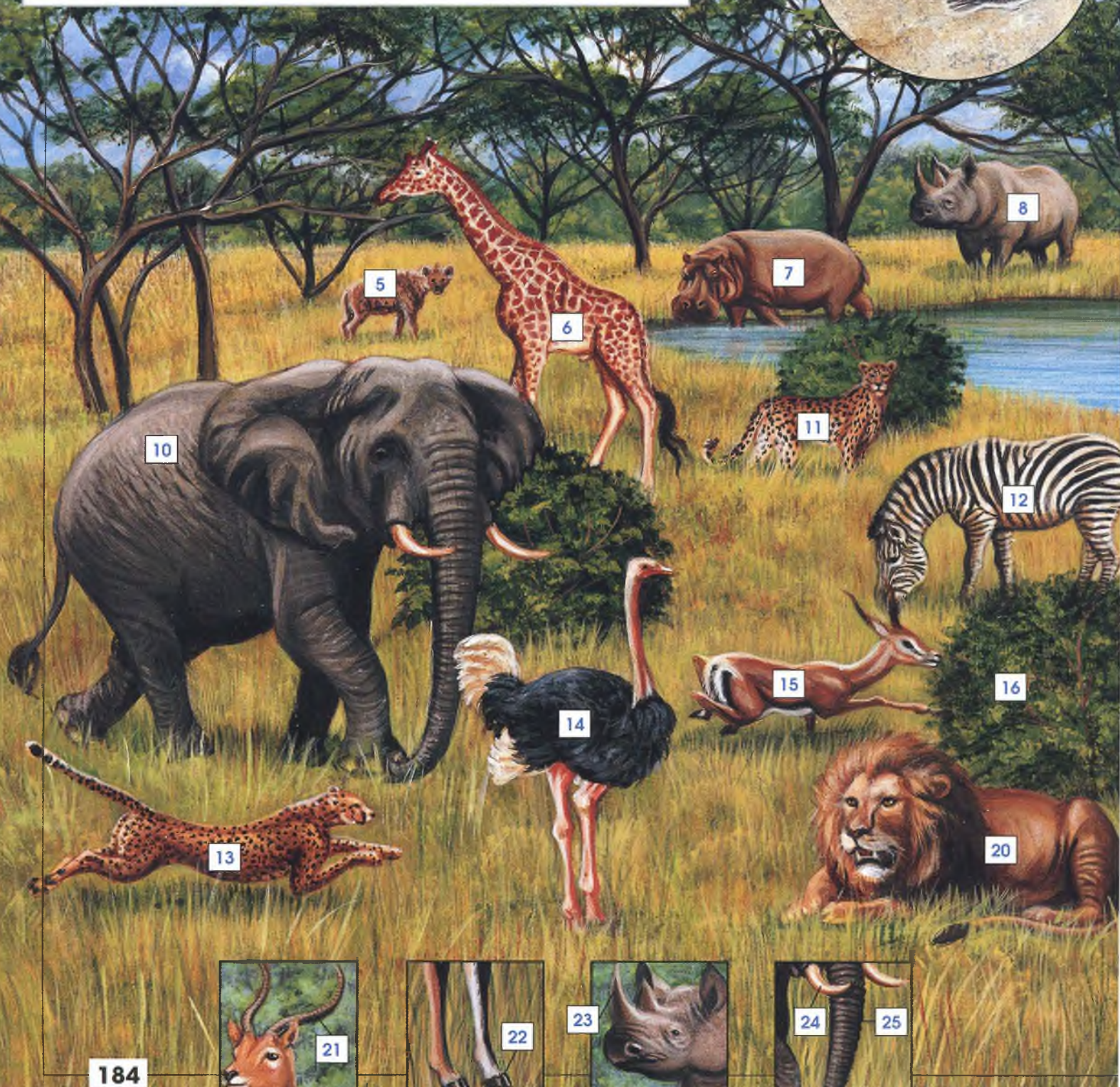

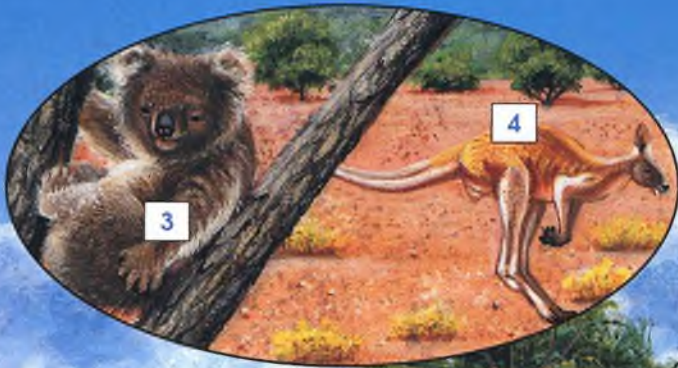

- | | |
|------------------|---------------------|
| 1 a bee | 16 a shrub / a bush |
| 2 a fossil | 17 a buffalo |
| 3 a koala | 18 a sparrow |
| 4 a kangaroo | 19 a gopher |
| 5 a hyena | 20 a lion |
| 6 a giraffe | 21 an antler |
| 7 a hippopotamus | 22 a hoof |
| 8 a rhinoceros | 23 a horn |
| 9 an antelope | 24 a tusk |
| 10 an elephant | 25 a trunk |
| 11 a leopard | 26 a mane |
| 12 a zebra | 27 a paw |
| 13 a cheetah | 28 fur |
| 14 an ostrich | 29 a tail |
| 15 a gazelle | |

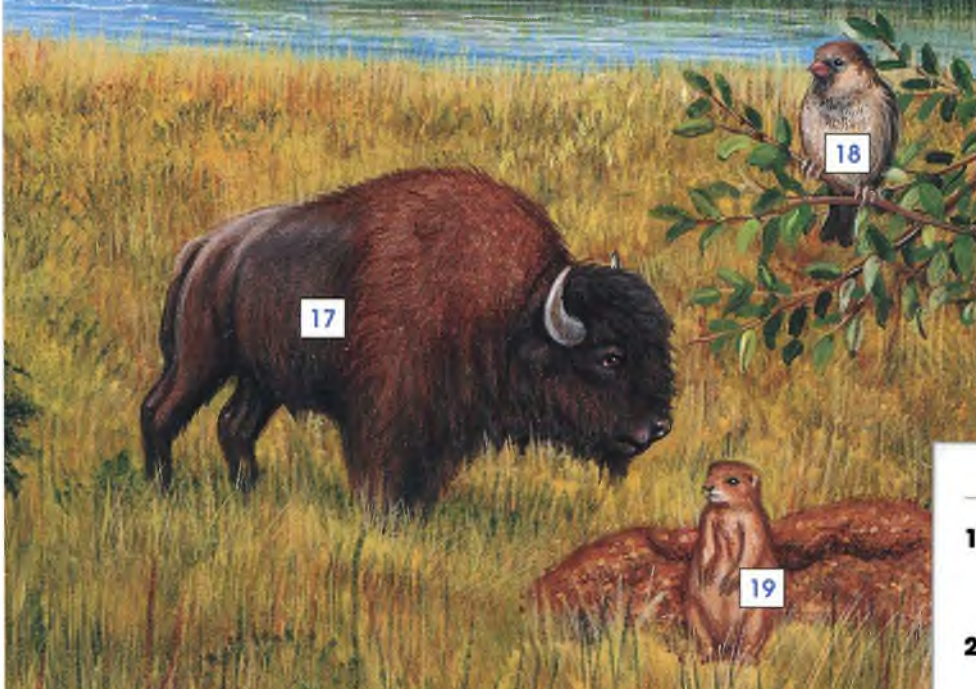

Word Partnerships

a herd of	antelope
	buffalo
	elephants
lions	roar
bees	buzz
hyenas	laugh

Words in Action

- Which animals on the list have fur? Which have a tail? Which have paws? Make lists with a partner.
- Describe an animal to a partner. Your partner says the name and points to the correct picture.
 - Student A: *It's big and it has two horns on its head.*
 - Student B: (pointing to the rhinoceros) *It's a rhinoceros.*





Polar Lands

Words in Context

Many animals live on the ice or in the waters near the North Pole. They stay warm in different ways. The **whale** and the **walrus** have thick layers of body fat. The arctic **fox** and the **polar bear** stay warm in their thick, white fur. Even **moss** finds a way to stay warm. It grows over rocks facing the sun.



6



8



9

11



10

Word Partnerships

a humpback whale

a blue

a Canada goose

a wild

a pack of wolves

a flock of birds

- | | | | | |
|--------------------|------------------|--------------|--------------|--------------|
| 1 a goose | 6 moss | 11 a fox | 16 whiskers | 21 a wing |
| 2 a moose | 7 an otter | 12 a seal | 17 a tusk | 22 a claw |
| 3 a reindeer | 8 a (polar) bear | 13 a penguin | 18 a flipper | 23 a feather |
| 4 a wolf | 9 a (bear) cub | 14 a whale | 19 a falcon | |
| 5 a (grizzly) bear | 10 an iceberg | 15 a walrus | 20 a beak | |

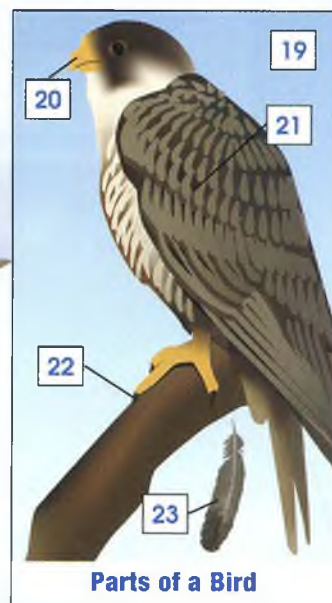
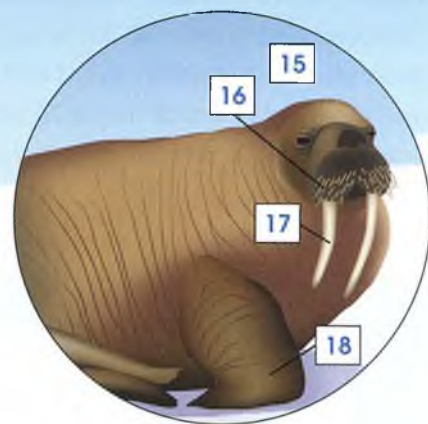

14



Words in Action

- Which polar animals eat meat? Which eat plants? Discuss these questions with your classmates.
- In a group, make one list of the polar animals with wings, a second list of the animals with flippers, and a third list of the animals with claws. Compare lists among groups.



Sea

Words in Context

There are more than 15,000 kinds of **fish** in the **sea**. The largest fish is the **shark**. The great white shark can grow to over 7 meters*. There are also some very fast fish in the sea. For example, the **swordfish** swims at about 90 kilometers** per hour, and the **tuna** swims at about 70 kilometers*** per hour. The slowest fish is the **sea horse**. It only swims about 0.001 kilometers per hour!

* 7 meters = 23.1 feet ** 90 kilometers = 55.8 miles *** 70 kilometers = 43.4 miles

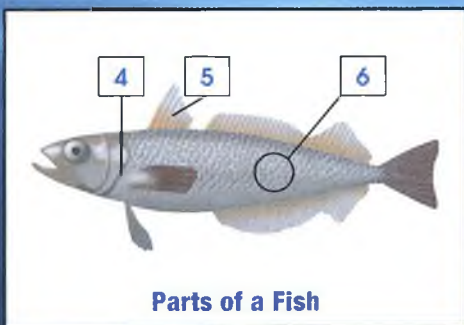

9



7



1



2



10



11



13



14

Word Partnerships

- | | |
|---------------|--------|
| a school of | fish |
| a freshwater | |
| a saltwater | |
| a sea | turtle |
| a snapping | |
| a hammerhead | shark |
| a great white | |



15

16



23

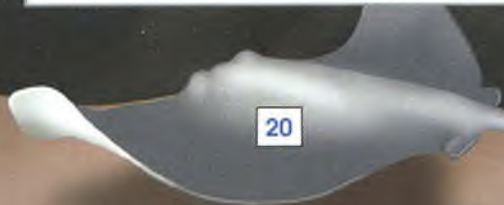

20



21



22



24

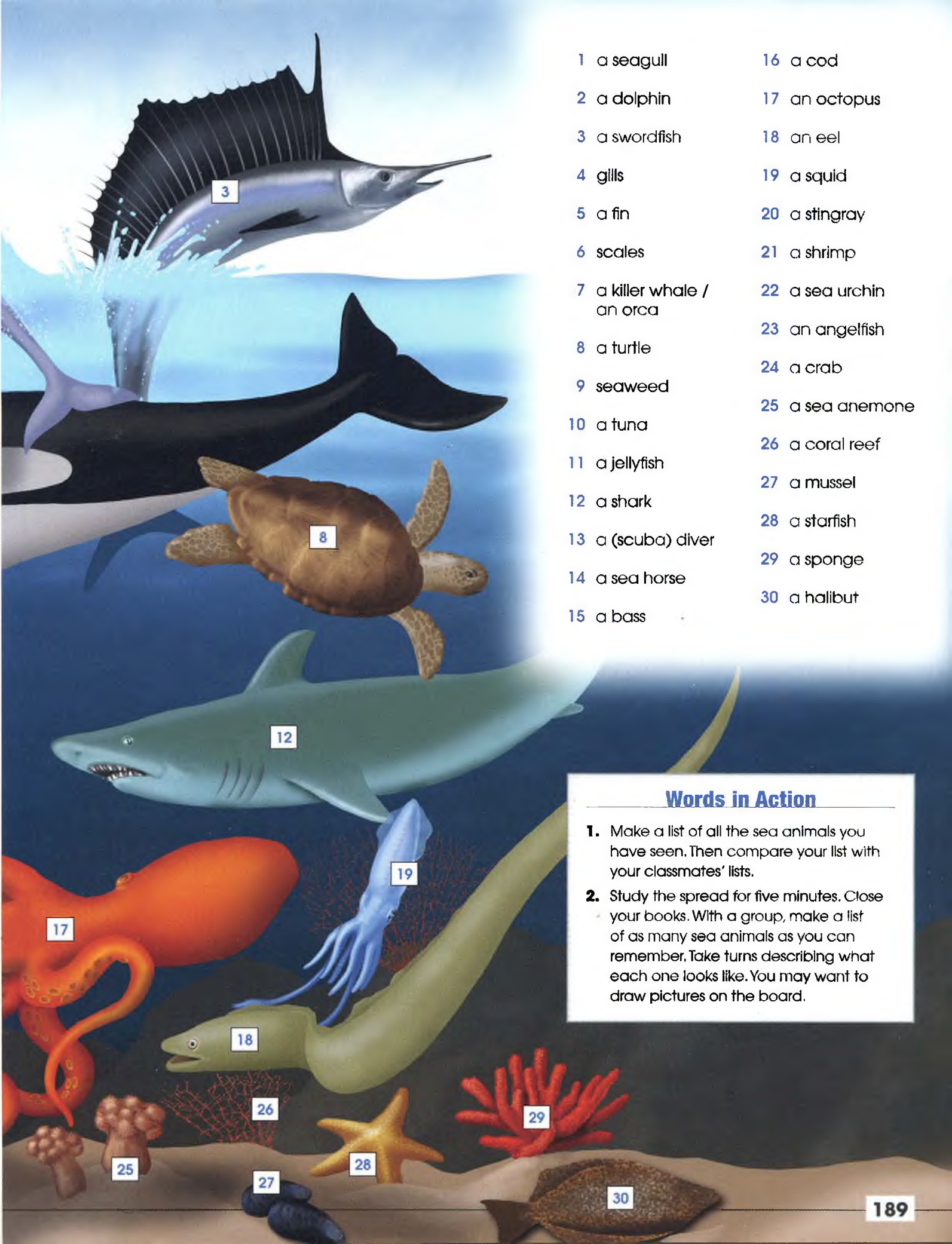

- | | |
|-------------------------------|------------------|
| 1 a seagull | 16 a cod |
| 2 a dolphin | 17 an octopus |
| 3 a swordfish | 18 an eel |
| 4 gills | 19 a squid |
| 5 a fin | 20 a stingray |
| 6 scales | 21 a shrimp |
| 7 a killer whale /
an orca | 22 a sea urchin |
| 8 a turtle | 23 an angelfish |
| 9 seaweed | 24 a crab |
| 10 a tuna | 25 a sea anemone |
| 11 a jellyfish | 26 a coral reef |
| 12 a shark | 27 a mussel |
| 13 a (scuba) diver | 28 a starfish |
| 14 a sea horse | 29 a sponge |
| 15 a bass | 30 a halibut |

Words in Action

1. Make a list of all the sea animals you have seen. Then compare your list with your classmates' lists.
2. Study the spread for five minutes. Close your books. With a group, make a list of as many sea animals as you can remember. Take turns describing what each one looks like. You may want to draw pictures on the board.



Woodlands

Words in Context

Woodland animals have many different homes. Some, like **moles** and **rabbits**, live underground. **Cardinals**, **blue jays**, and other birds make their **nests** in trees. **Squirrels** also live in trees and keep their nuts and berries there.

- | | |
|-----------------|-----------------|
| 1 a robin | 16 a mole |
| 2 a cardinal | 17 a salamander |
| 3 a nest | 18 a worm |
| 4 a blue jay | 19 a raccoon |
| 5 an eagle | 20 a toad |
| 6 a bobcat | 21 a chipmunk |
| 7 an opossum | 22 a skunk |
| 8 a squirrel | 23 a dragonfly |
| 9 a deer | 24 a mosquito |
| 10 a groundhog | 25 a tick |
| 11 a porcupine | 26 a hornet |
| 12 a turkey | 27 a ladybug |
| 13 a woodpecker | 28 a rabbit |
| 14 a duck | 29 a mouse |
| 15 a beaver | |

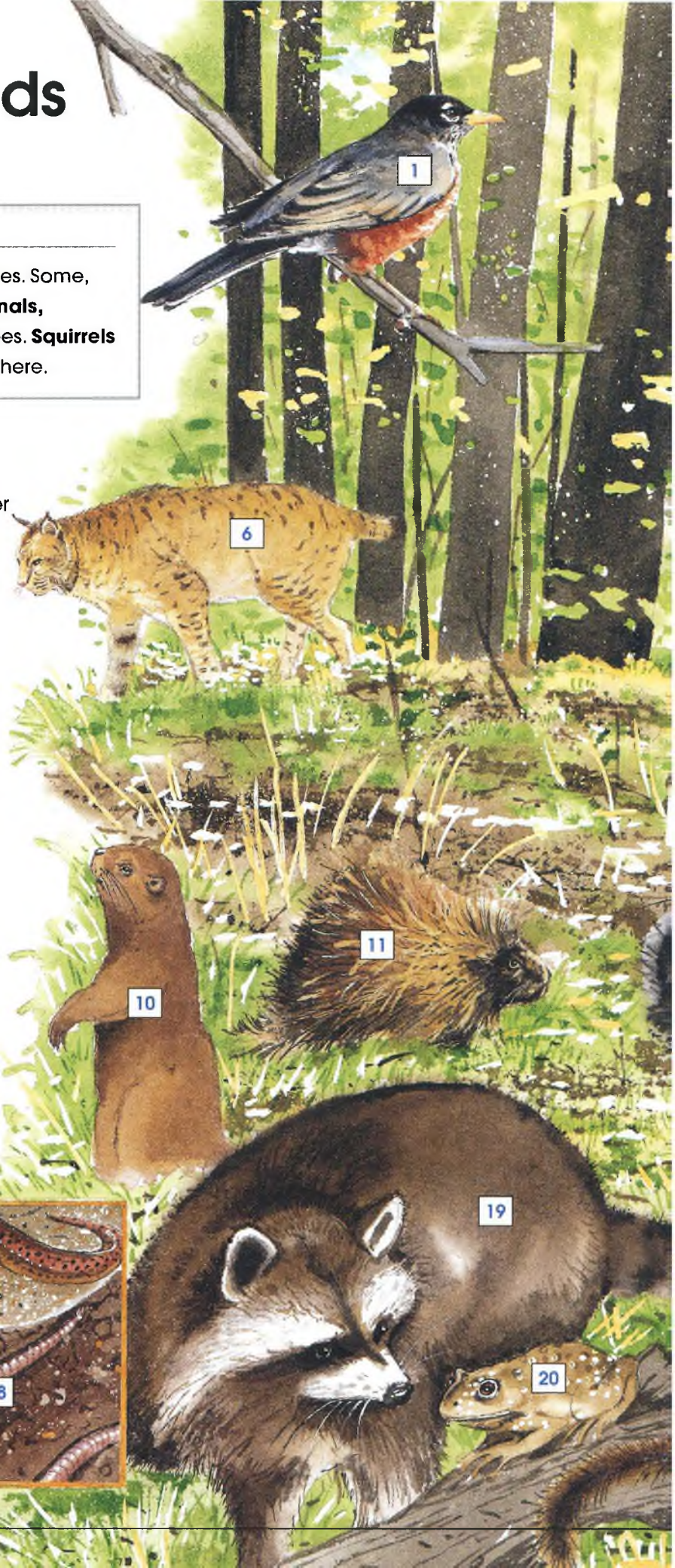

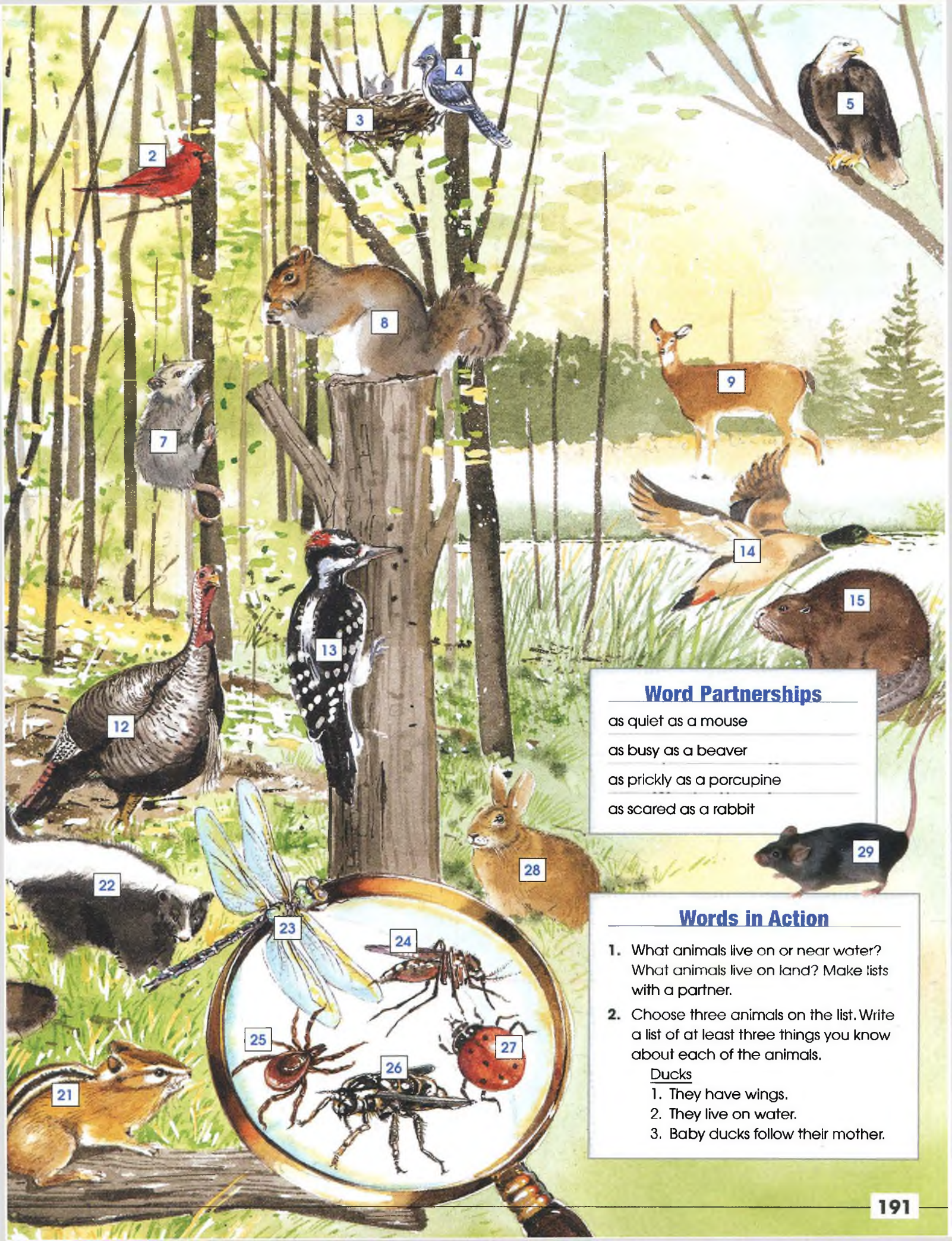

Word Partnerships

- as quiet as a mouse
- as busy as a beaver
- as prickly as a porcupine
- as scared as a rabbit

Words in Action

1. What animals live on or near water? What animals live on land? Make lists with a partner.
2. Choose three animals on the list. Write a list of at least three things you know about each of the animals.

Ducks

1. They have wings.
2. They live on water.
3. Baby ducks follow their mother.



Math

Words in Context

You use **math** every day. You use **subtraction** to balance your checkbook. You use **fractions** to cook. You use **addition** to add up the total on a restaurant bill. You may even use **geometry** to decorate your home. Geometry can help you figure out how much wallpaper you need for your walls and how much carpet you need for your floors.

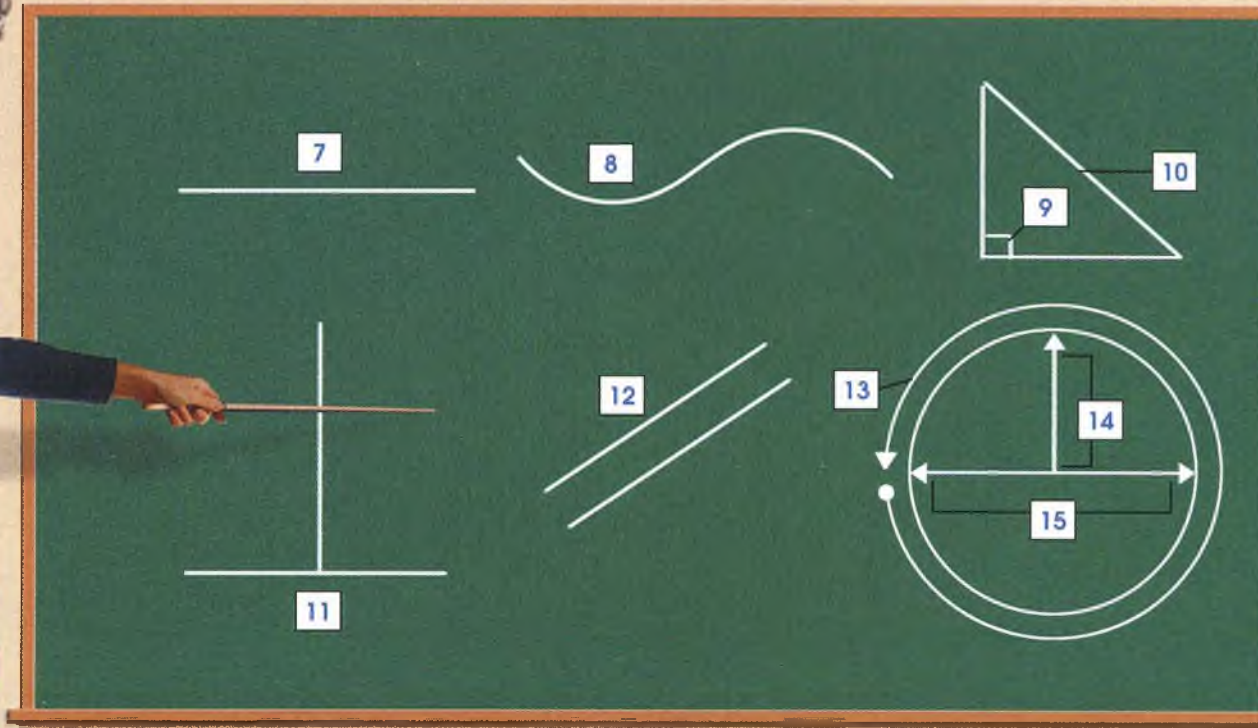

26 $6 + 3 = 9$

27 $6 - 3 = 3$

28 $6 \times 3 = 18$

29 $3 \div 6 = \frac{1}{2}$

30

Word Families

Noun

addition

subtraction

multiplication

division

Verb

add

subtract

multiply

divide

- | | | | |
|-------------------------|------------------------|----------------|-------------------|
| 1 plus | 9 an angle | 17 an oval | 25 a cylinder |
| 2 minus | 10 a side | 18 a rectangle | 26 addition |
| 3 equals | 11 perpendicular lines | 19 a triangle | 27 subtraction |
| 4 percent | 12 parallel lines | 20 a square | 28 multiplication |
| 5 multiplied by / times | 13 the circumference | 21 a pyramid | 29 division |
| 6 divided by | 14 the radius | 22 a cube | 30 a fraction |
| 7 a straight line | 15 the diameter | 23 a sphere | 31 geometry |
| 8 a curved line | 16 a circle | 24 a cone | 32 algebra |

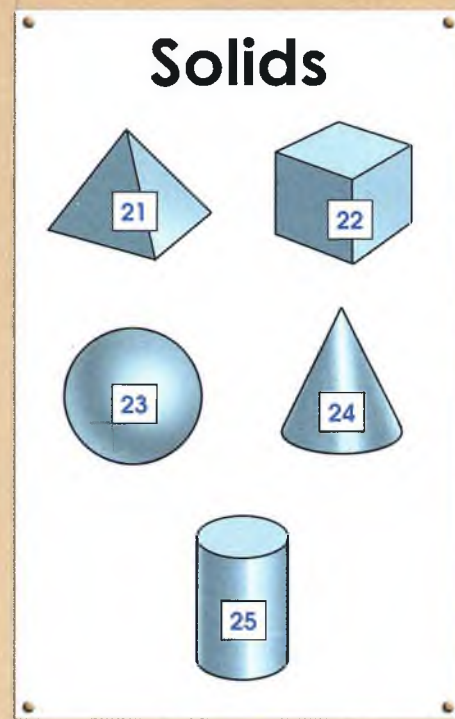
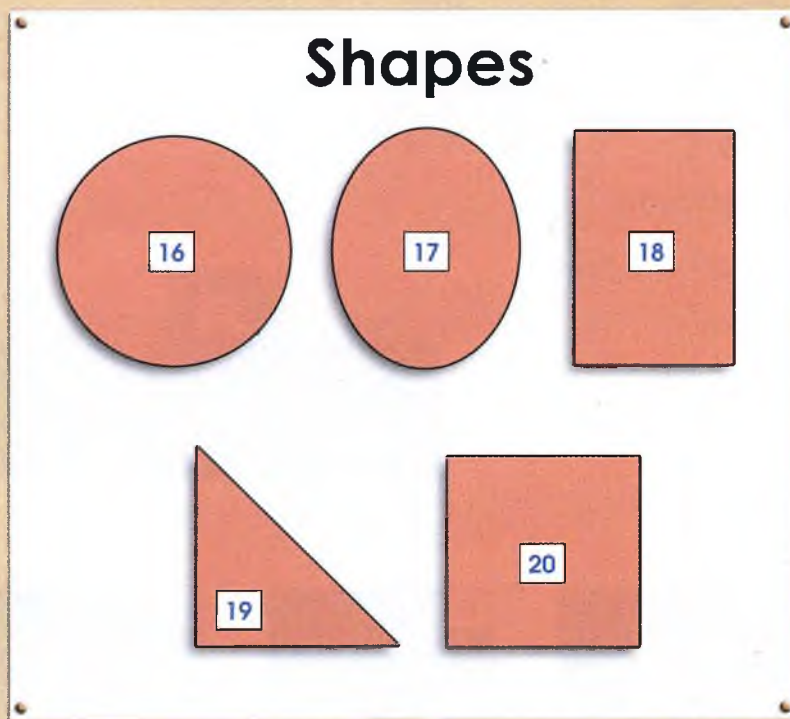

31

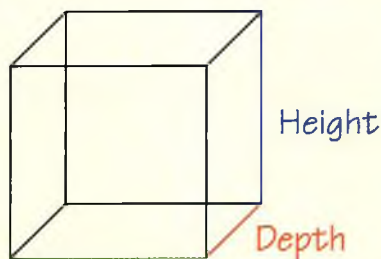

$$W \times D \times H = V$$

32

$$ax^2 + bx + c = 0$$

Words in Action

- Look around your classroom. Find an example of each of the shapes on the list. Share your ideas with the class.
 - My desk is a rectangle and the clock is a circle.
- Work with a partner. One student writes down a math problem. The other student figures out the answer, then reads the problem and the answer out loud.
 - Student A: (writes: $3 + 3$)
 - Student B: *Three plus three equals six.*



Science

Words in Context

The famous **physicist** Albert Einstein won the Nobel Prize in **Physics** for his ideas about space and time. He is also famous for his **formula** $E = mc^2$. There is even an **element** in the **periodic table** named after Einstein. It's called *einsteinium*.



- 1 biology
- 2 a biologist
- 3 chemistry
- 4 a chemist
- 5 physics
- 6 a physicist
- 7 a prism
- 8 forceps
- 9 a balance
- 10 a solid
- 11 a liquid
- 12 a gas
- 13 a test tube
- 14 a Bunsen burner
- 15 the periodic table
- 16 an element
- 17 an atom
- 18 a molecule
- 19 a formula
- 20 a graduated cylinder
- 21 a dropper
- 22 a stopper
- 23 a beaker
- 24 a flask
- 25 a microscope
- 26 a magnifying glass
- 27 a funnel
- 28 a slide
- 29 a petri dish
- 30 a magnet

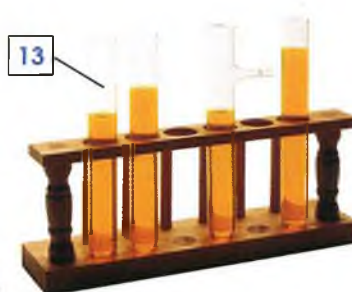
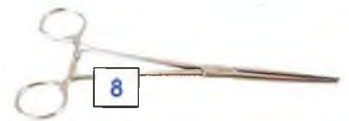

Word Partnerships

- | |
|------------------------------|
| a biology class |
| a chemistry lab / laboratory |

Word Families

- | Noun | Adjective |
|------------|-------------|
| atom | atomic |
| magnet | magnetic |
| microscope | microscopic |
| liquid | liquid |
| solid | solid |

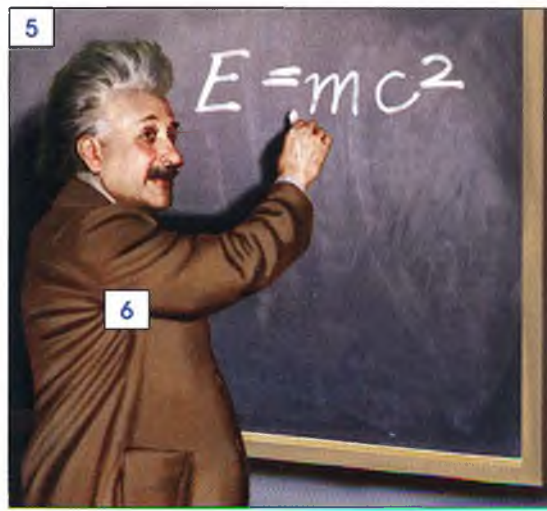
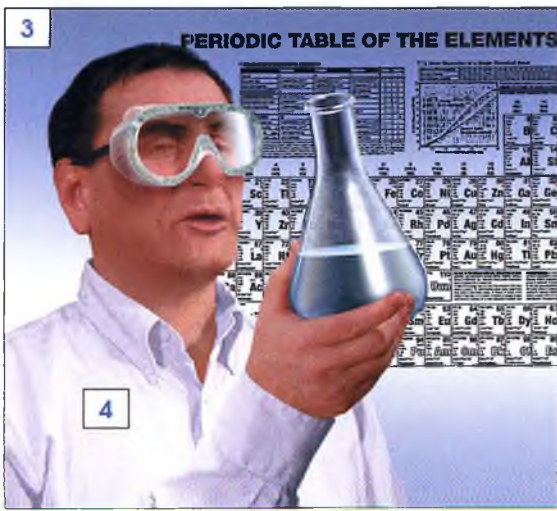

15

PERIODIC TABLE AND ATOMIC DATA
WITH ILLUSTRATED TEXT OF NUCLEAR TERMS

NOBLE GASES 18

1 H	2 He											18 Ar	19 K	20 Ca			
3 Li	4 Be	5 B	6 C	7 N	8 O	9 F	10 Ne								18 Ar	19 K	20 Ca
11 Na	12 Mg	13 Al	14 Si	15 P	16 S	17 Cl	18 Ar								18 Ar	19 K	20 Ca
19 K	20 Ca	21 Sc	22 Ti	23 V	24 Cr	25 Mn	26 Fe	27 Co	28 Ni	29 Cu	30 Zn	31 Ga	32 Ge	33 As	34 Se	35 Br	36 Kr
37 Rb	38 Sr	39 Y	40 Zr	41 Nb	42 Mo	43 Tc	44 Ru	45 Rh	46 Pd	47 Ag	48 Cd	49 In	50 Sn	51 Sb	52 Te	53 I	54 Xe
55 Cs	56 Ba	57 La	58 Ce	59 Pr	60 Nd	61 Pm	62 Sm	63 Eu	64 Gd	65 Tb	66 Dy	67 Ho	68 Er	69 Tm	70 Yb	71 Lu	
87 Fr	88 Ra	89 Ac	90 Th	91 Pa	92 U	93 Np	94 Pu	95 Am	96 Cm	97 Bk	98 Cf	99 Es	100 Fm	101 Md	102 No	103 Lr	

16

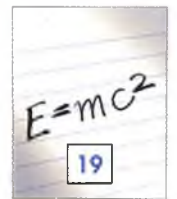

Words in Action

- Work with a partner. One person describes a laboratory object from the list. The other guesses the object. Take turns.
 - Student A: *You use this to pour liquid into a beaker.*
 - Student B: *A funnel.*
- Put the items on the word list into three groups: items you find in a physics lab, items you find in a biology lab, and items you find in a chemistry lab. Compare lists with another student. (Note: Some items can be on more than one list.)



Writing

Words in Context

Writing an **essay** is a process. First you **brainstorm** ideas. Next you **write** an outline, and then you write a draft. Before you **edit**, you **get** feedback. Are you ready to write the final draft? Before you do, make sure the **punctuation** is correct. Have you used **capital letters** for the first letter of each **word** in the **title**? Have you indented each **paragraph**? If so, now you are ready to write the final draft.

1 a letter

2 a word

3 a sentence

4 a paragraph

5 a paper / an essay

6 an indentation

7 a margin

8 a title

9 punctuation

10 a period

11 a comma

12 a question mark

13 an exclamation point / an exclamation mark

14 an apostrophe

15 parentheses

16 quotation marks

17 a colon

18 a semicolon

19 a hyphen

Verbs



20 brainstorm ideas



21 write an outline



22 write a draft



23 get feedback



24 edit your essay



25 type your final draft

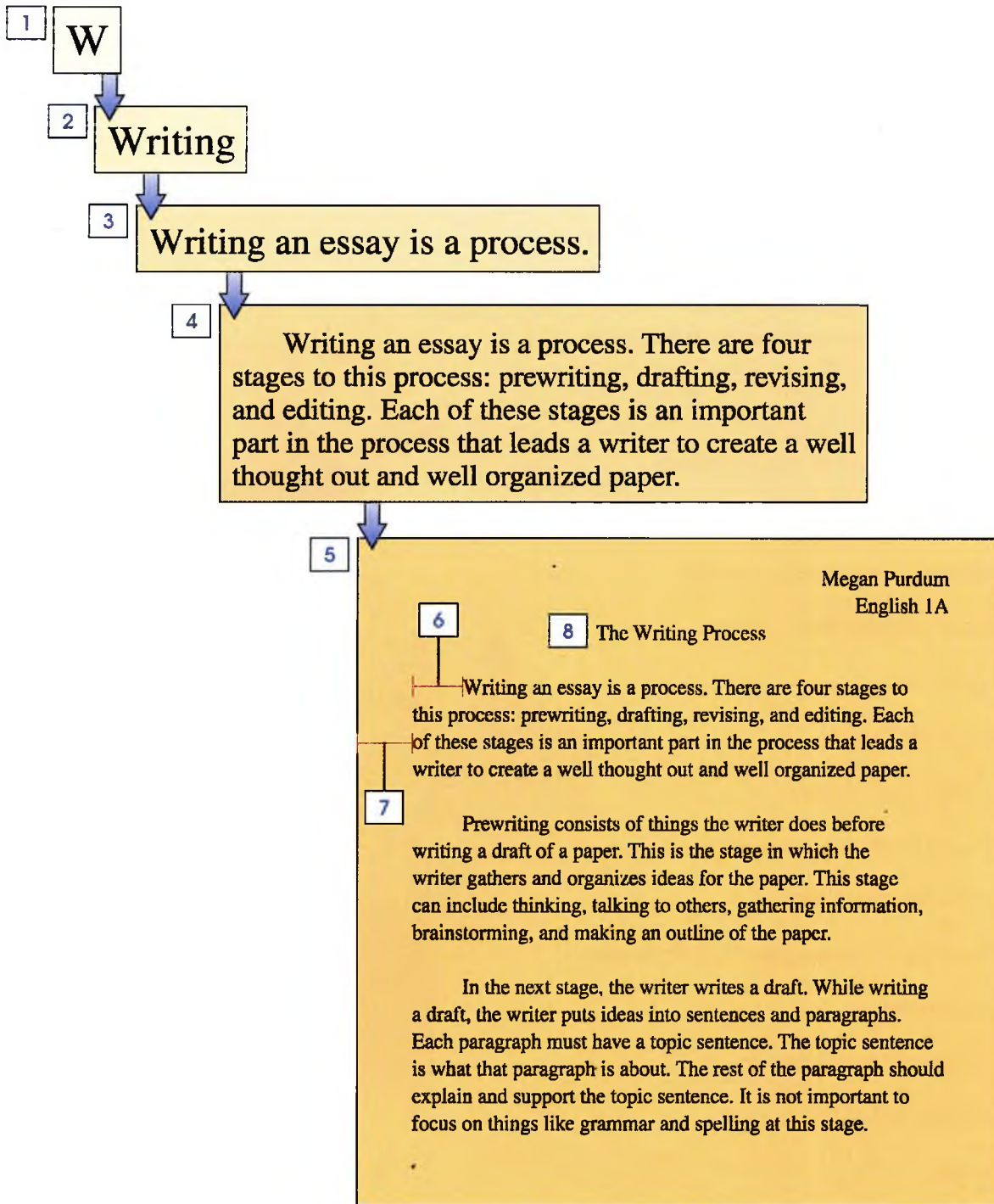

9

10 .

11 ,

12 ?

13 !

14 ,

15 ()

16 “ ”

17 :

18 ;

19 -

Word Partnerships	
a capital / an uppercase letter	letter
a lowercase	
a vocabulary word	word
a slang	
a one-syllable	
a two-syllable	
a term	paper
a research	

- ### Words in Action
- Look at a magazine or newspaper article. Find and circle the following:
 - a comma
 - an apostrophe
 - a sentence
 - a paragraph
 - What are the steps in writing a paper? Discuss with a partner.



Explore, Rule, Invent

Words in Context

Humans have achieved amazing things. We have **composed** operas and poetry. We have **discovered** cures for diseases. We have **sailed** the world's oceans and **explored** the continents. We have **launched** rockets into space and **reached** the moon.

- 1 Humans **migrate** from Asia to the Americas.
- 2 Mesopotamians **produce** the first wheel.
- 3 The Egyptians **build / construct** pyramids.
- 4 The Vikings **sail** to present-day Canada.
- 5 The Chinese **grow** tea.
- 6 Joan of Arc **defends** France.
- 7 Montezuma I **rules** the Aztecs.
- 8 Amerigo Vespucci **explores** the Amazon.
- 9 Sir Isaac Newton **discovers** gravity.
- 10 Ludwig van Beethoven **composes** his first symphony.
- 11 The Suez Canal **opens**.
- 12 Thomas Edison **invents** the lightbulb.
- 13 The Wright brothers **fly** the first plane.
- 14 World War II **ends**.
- 15 The Soviet Union **launches** the first satellite.
- 16 Martin Luther King Jr. **wins** the Nobel Peace Prize.
- 17 Japan **introduces** the high-speed "bullet" train.
- 18 Apollo 11 astronauts **reach** the moon.
- 19 The Berlin Wall **falls**.
- 20 South Africa **elects** Nelson Mandela president.

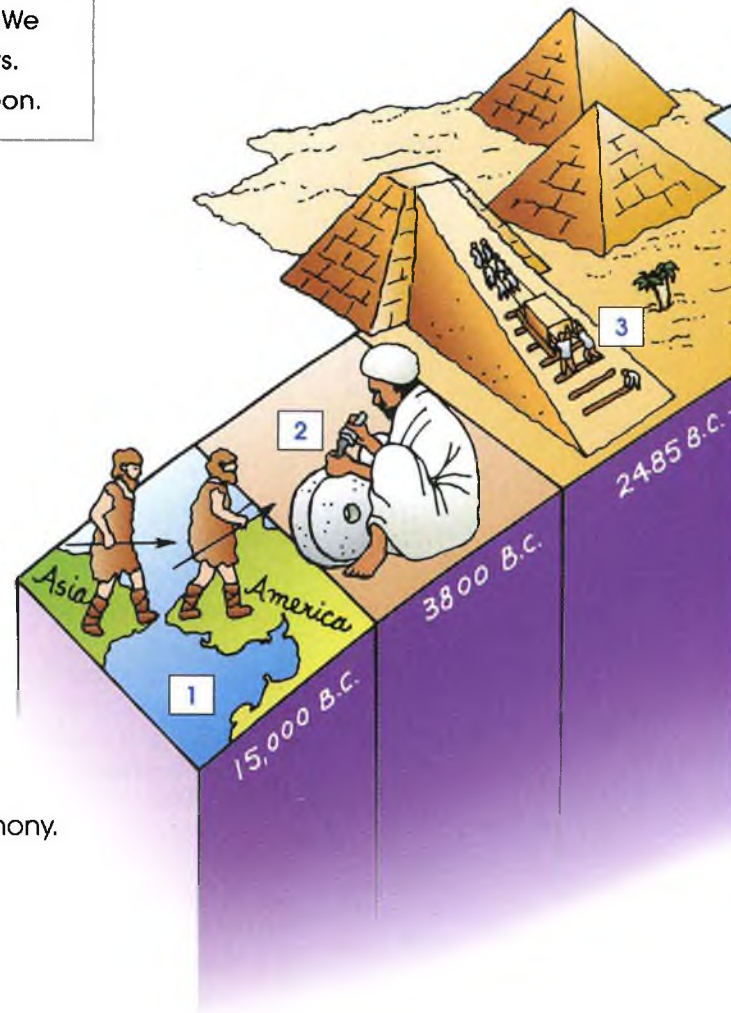

Word Partnerships

win	a war
	a contest
compose	a song
	a letter
elect	a prime minister
	a president
	a mayor
build	a road
	a bridge

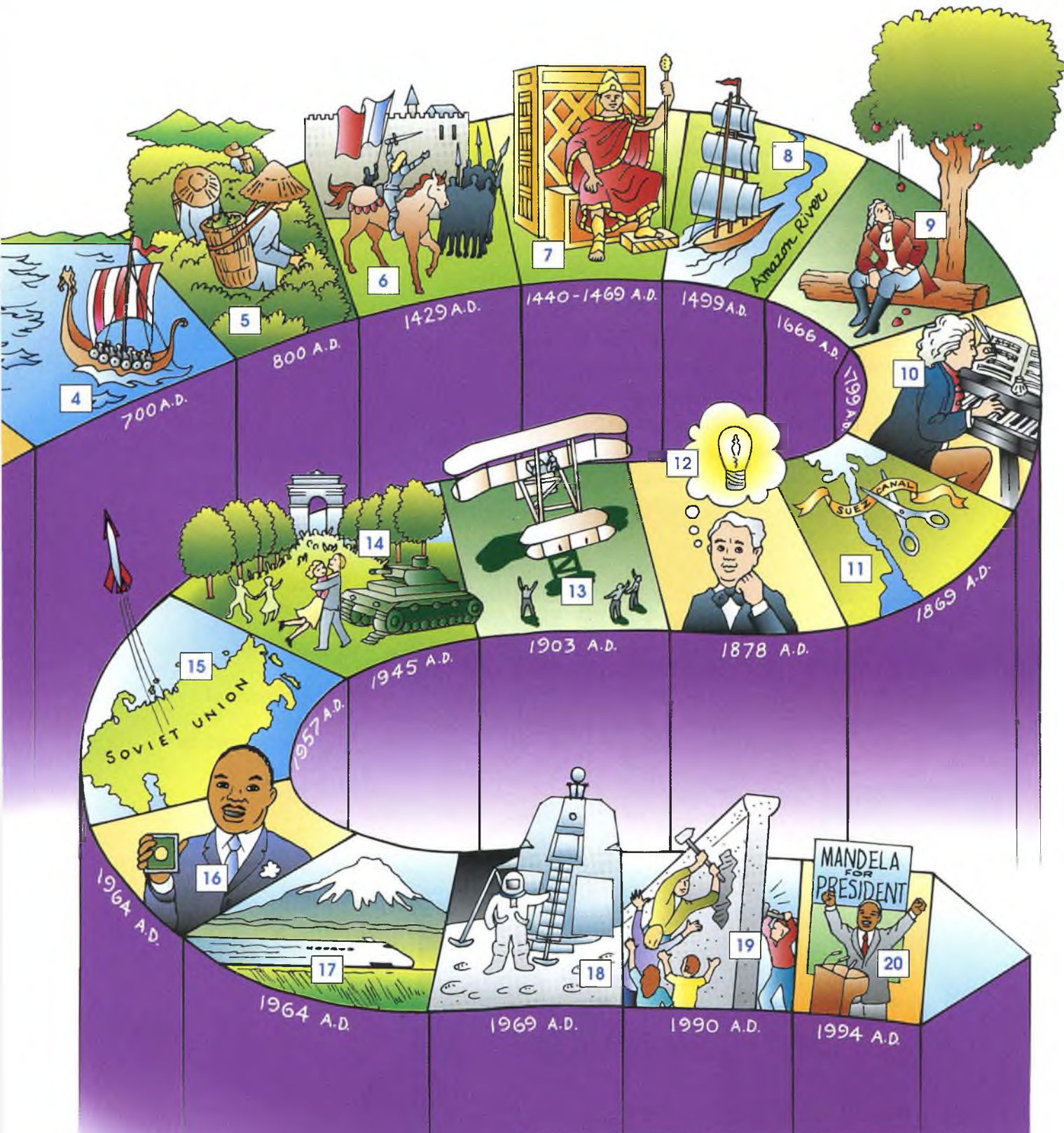

Words in Action

1. Work with a partner. Cover the sentences. One student points to a picture. The other says the event. Take turns.
2. Work with a partner. One student says one of the verbs from the verb list. The other student uses that verb in a sentence.
 - Student A: *Invent*
 - Student B: *Alexander Graham Bell invented the telephone.*



U.S. Government and Citizenship

Words in Context

The U.S. **government** has three parts. These parts are called *branches*. The executive branch includes the **president** and the **vice president**. The legislative branch includes the **House of Representatives** and the **Senate**. There are 100 **senators** in the Senate and 435 **congressmen** and **congresswomen** in the House of Representatives. The judicial branch includes nine **Supreme Court justices**.

- 1 a (political) candidate
- 2 a ballot
- 3 a voting booth
- 4 a citizen
- 5 the U.S. Constitution
- 6 the Capitol (Building)
- 7 the White House
- 8 the Supreme Court
- 9 a congresswoman /
a congressman
- 10 a senator
- 11 the president
- 12 the vice president
- 13 the justices

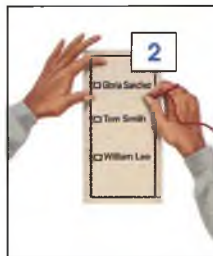
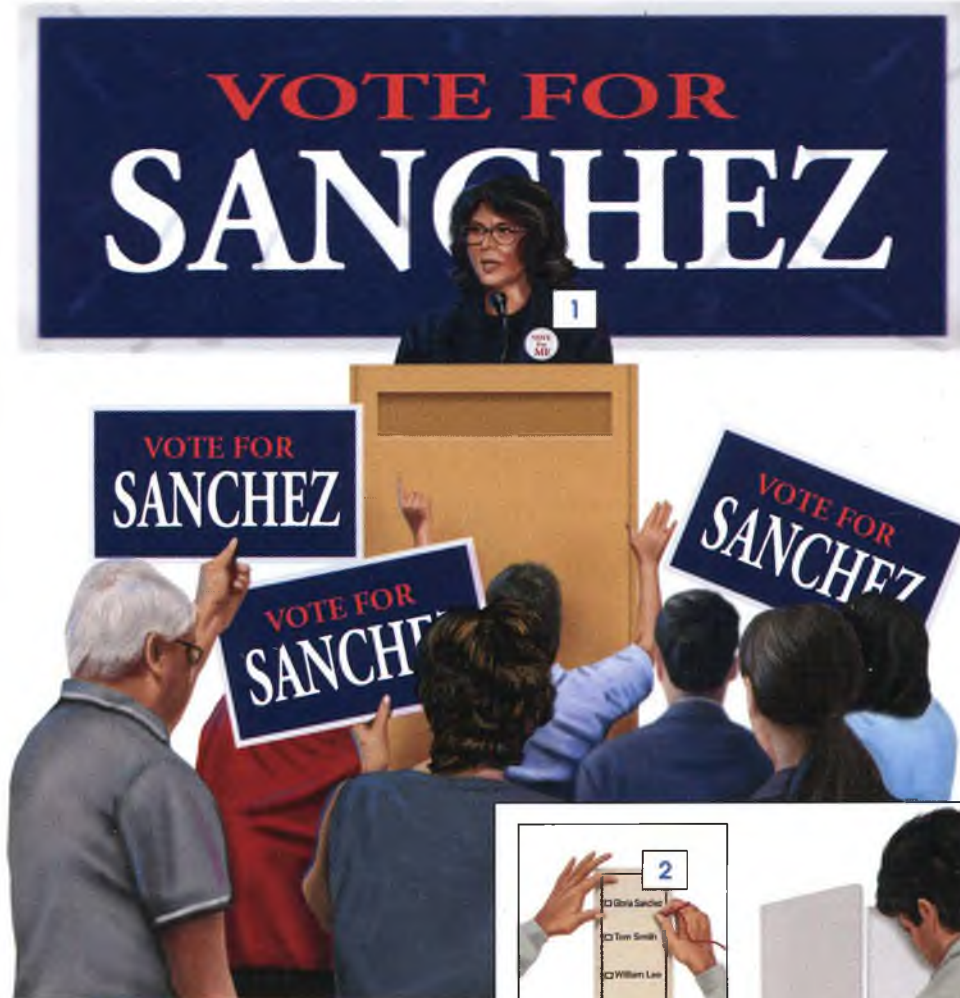

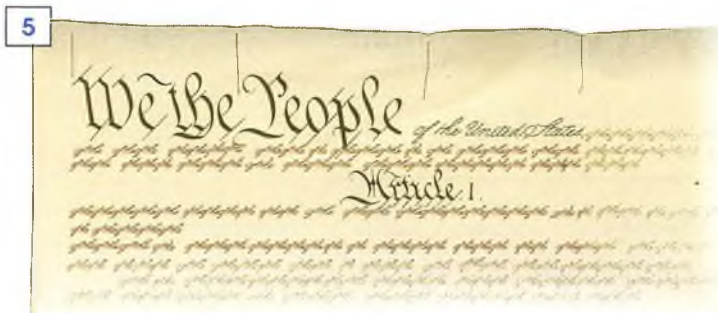

5



6

Legislative Branch

Congress

House of Representatives

Senate



9



10



7

Executive Branch



11



12



8

Judicial Branch



13

Verbs



14 vote



15 obey the law



16 pay taxes



17 serve on a jury



18 protest / demonstrate



19 serve in the military

Word Partnerships

- a United States citizen
- senator
- congressman

Words in Action

1. Compare the U.S. government with the government of another country. How are they similar? How are they different?
2. Discuss which branch of the U.S. government you think is most important. Explain your reasons.



Fine Arts

Words in Context

Pablo Picasso is probably the most famous artist of the last 100 years. His **portraits** and **still lifes** hang in the world's great museums. Picasso worked as a **painter**, **sculptor**, and **potter**. He **Painted** with oils and watercolors, and he sculpted in **clay**.



- 1 a frame
- 2 a still life
- 3 a portrait
- 4 a landscape

- 5 a model
- 6 a palette
- 7 a painting
- 8 a paintbrush
- 9 a painter

- 10 paint
- 11 an easel
- 12 a canvas
- 13 a sketchpad
- 14 a sketch

- 15 a mural
- 16 a sculpture
- 17 a sculptor
- 18 pottery
- 19 a potter
- 20 a potter's wheel
- 21 clay
- 22 a photograph
- 23 a photographer

Verbs



24 draw



25 paint



26 photograph / take a photograph



Word Partnerships

modern	art
a work of	
oil	paint
acrylic	
watercolor	
a watercolor	painting
an oil	

Words in Action

1. Work with a group. Make a list of famous artists. Answer the following questions about each:
 - What kind of artist is he/she?
 - What materials did/does this artist use?
 - Do you know the names of any of the artist's works?
2. What is your favorite kind of art? Why? Discuss with a partner.



Performing Arts

Words in Context

Different **performing arts** began in different countries around the world. For example, theater began in ancient Greece. The **actors** wore **masks** and performed **plays** in large outdoor theaters. **Opera** began in Italy at the end of the 16th century, and soon became popular in France and Germany. **Ballet** also began in Italy at the end of the 16th century, and it became very popular in France while Louis XIV was king.

- 1 a ballet
- 2 a balcony
- 3 a dancer
- 4 a mask
- 5 a costume
- 6 a stage
- 7 a conductor
- 8 an orchestra
- 9 an audience

Verbs



26 clap / applaud

27 bow

Word Partnerships

- a ballet
- a tap
- a ballroom
- a flamenco
- a belly
- an opera
- a nightclub
- a lead
- a backup
- dancer
- singer

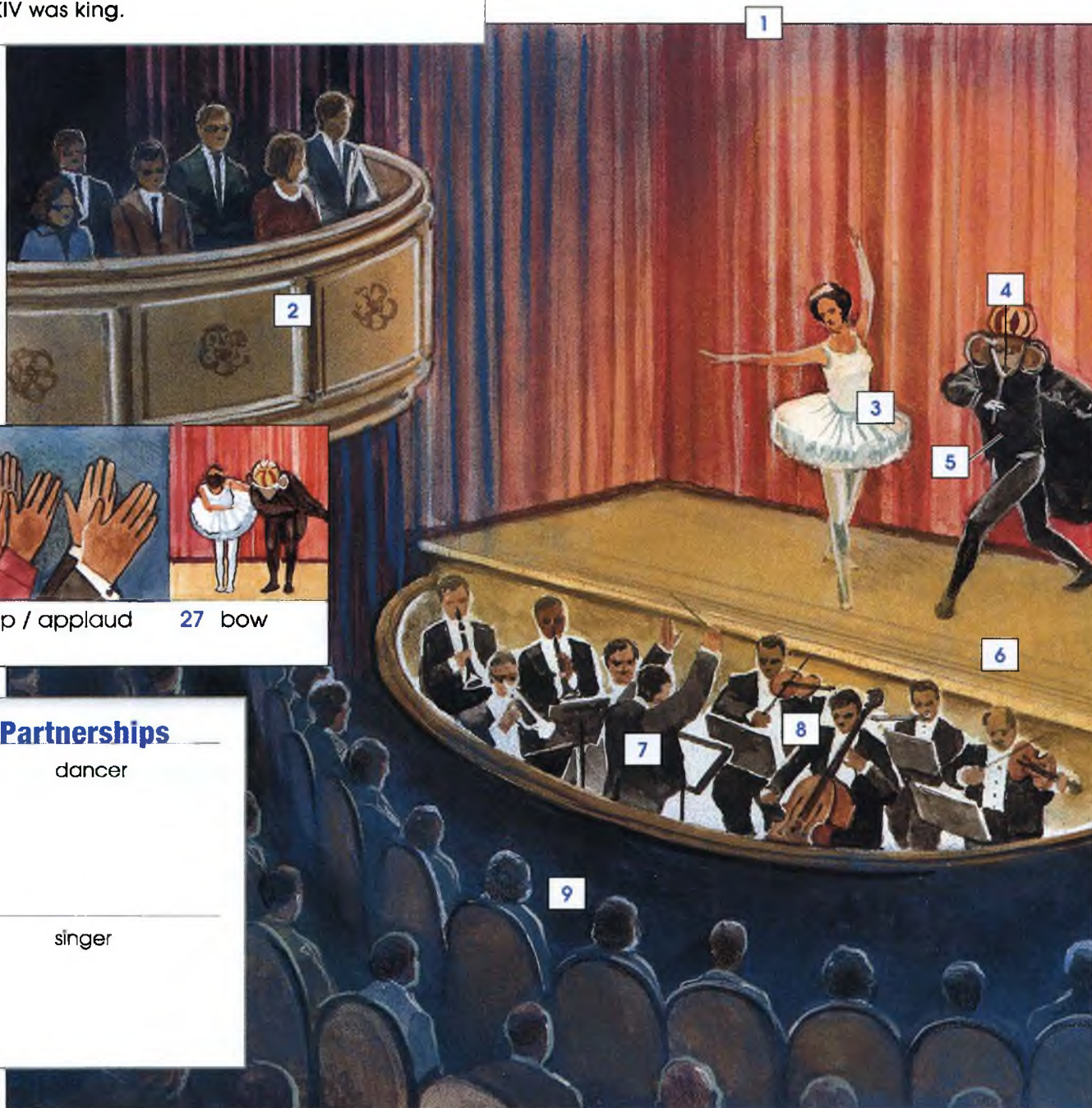

- | | |
|---------------------|-----------------|
| 10 a (rock) concert | 18 an actor |
| 11 a spotlight | 19 a set |
| 12 a drummer | 20 a seat |
| 13 a microphone | 21 an usher |
| 14 a singer | 22 a ticket |
| 15 a guitarist | 23 a program |
| 16 backup singers | 24 a box office |
| 17 a play | 25 an opera |



Words in Action

1. Have you ever seen a ballet? An opera? A play? Choose your favorite and tell a partner about it.
2. Imagine you are the directors of a new arts center. What kinds of concerts, plays, and other performances will you present this year? Discuss with your group.



Instruments

Words in Context

Percussion instruments are thousands of years old. **Drums** are one of the oldest percussion instruments. They were part of African culture as early as 6000 B.C. The **tambourine** is also thousands of years old. Many countries, from Japan to Morocco to England, use tambourines in their music. Other percussion instruments include **maracas**, from Latin America, and **cymbals**, from China.

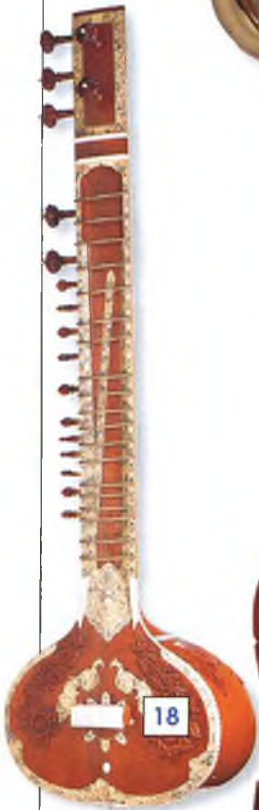

Word Partnerships

- | | |
|-------------|---------------|
| play | an instrument |
| tune | |
| practice | the piano |
| | the violin |
| | the cello |
| an acoustic | guitar |
| an electric | |
| a bass | |



Percussion

- 1 drums
- 2 cymbals
- 3 a tambourine
- 4 a marimba
- 5 maracas

Brass

- 6 a tuba
- 7 a French horn
- 8 a trombone
- 9 a trumpet
- 10 a bugle

Woodwind

- 11 a saxophone
- 12 a flute
- 13 an oboe
- 14 a clarinet
- 15 a bassoon
- 16 pan pipes
- 17 a harmonica

String

- 18 a sitar
- 19 a bass
- 20 a cello
- 21 a violin
- 22 a guitar
- 23 a banjo
- 24 a harp



Keyboard

- 25 an electric keyboard
- 26 a piano
- 27 an organ
- 28 an accordion



Words in Action

1. Make a list of famous musicians and the instruments they play.
2. Work with a partner. Pretend to play an instrument. Your partner will guess the instrument. Take turns.



Film, TV, and Music

Words in Context

My husband and I never agree on **films**. For example, my husband always wants to see **action** films or **horror movies**. I usually prefer **dramas** or **comedies**. But we have children, so we usually end up at **animated** films!



1



2



4



3



5



6



7



8



9

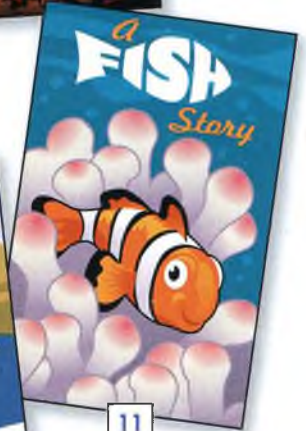

11

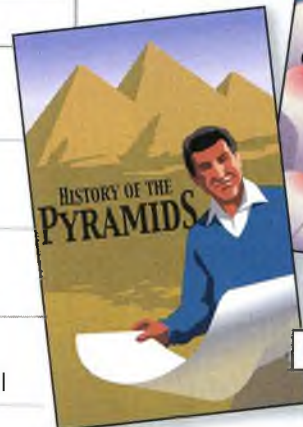

10

Films / Movies

- 1 action / adventure
- 2 comedy
- 3 mystery / suspense
- 4 drama
- 5 romance
- 6 science fiction
- 7 western
- 8 fantasy
- 9 horror
- 10 documentary
- 11 animated

Word Partnerships

an independent	film
a foreign	
a funny	movie
a scary	
satellite	TV
cable	
a TV	station
	commercial
loud	music
soft	

TV programs

- 12 news
- 13 sitcom
- 14 cartoon
- 15 game show
- 16 soap opera
- 17 talk show
- 18 nature program
- 19 children's program
- 20 sports
- 21 reality show



Music

- 22 pop
- 23 jazz
- 24 rock
- 25 blues
- 26 R&B / soul
- 27 hip hop
- 28 classical
- 29 country and western



Words in Action

1. With your class, make a list of:
 - action films
 - comedy films
 - sitcoms
 - game shows
2. What is your favorite kind of music? Why? Tell your partner.



Beach

Words in Context

There is a **beach** in Japan with perfect weather every day of the year. How is it possible? The beach at Ocean Dome is indoors! **Sunbathers** put their beach towels on the **sand** and relax. There is no sun, but it feels warm and sunny inside. **Swimmers** **swim** in a man-made **ocean**, and **surfers surf** on man-made **waves**!

Verbs



30 surf



31 dive



32 swim



33 float

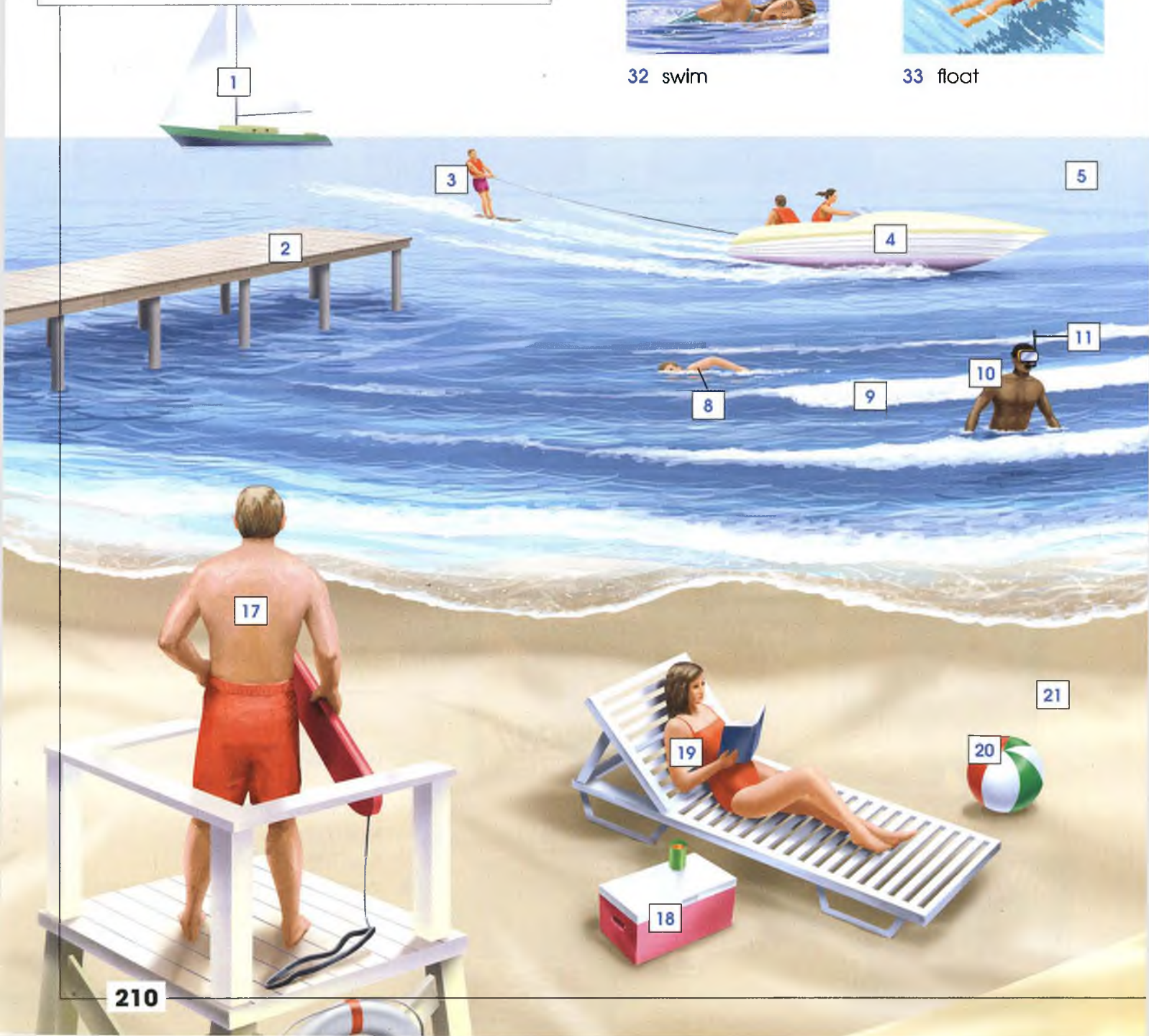

- 1 a sailboat
- 2 a pier
- 3 a water-skier
- 4 a motorboat
- 5 the ocean / the water
- 6 a ship
- 7 a lighthouse
- 8 a swimmer
- 9 a wave
- 10 a snorkeler
- 11 a snorkel
- 12 a sailboard
- 13 a sailboarder
- 14 a life jacket
- 15 a surfer
- 16 a surfboard
- 17 a lifeguard
- 18 a cooler
- 19 a sunbather
- 20 a beach ball
- 21 sand
- 22 a (sea)shell
- 23 a water wing
- 24 sunscreen
- 25 a sand castle
- 26 a (diving) mask
- 27 fins
- 28 a pail
- 29 a shovel

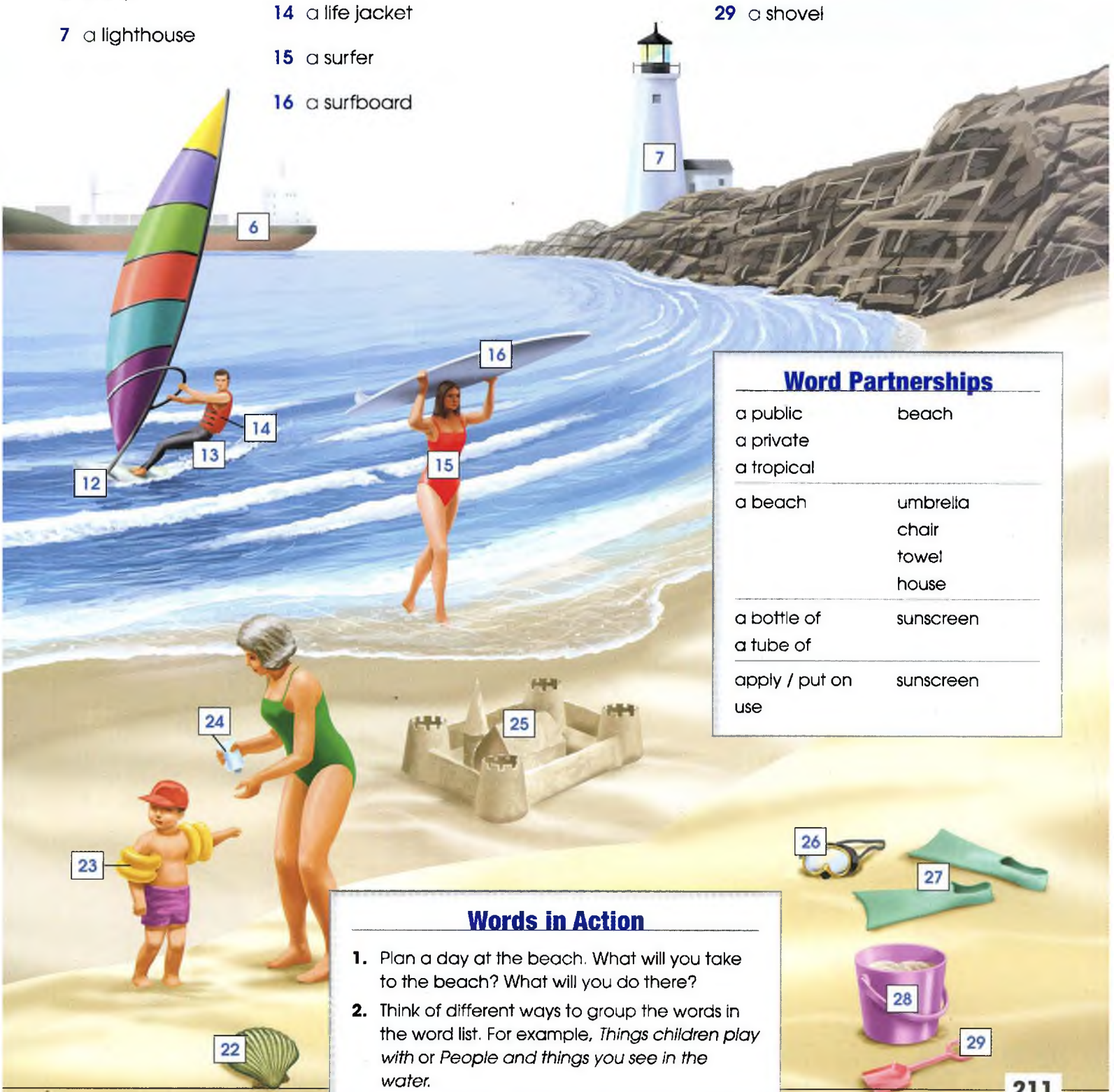

Word Partnerships

a public	beach
a private	
a tropical	
a beach	umbrella
	chair
	towel
	house
a bottle of	sunscreen
a tube of	
apply / put on	sunscreen
use	

Words in Action

1. Plan a day at the beach. What will you take to the beach? What will you do there?
2. Think of different ways to group the words in the word list. For example, *Things children play with* or *People and things you see in the water*.



Camping



Words in Context

The Appalachian Trail is a 2,174-mile* **trail** in the U.S. It starts in Maine and goes all the way to Georgia. Some people **hike** a small part of the trail for a day. Others hike longer portions of the trail. These **hikers** usually bring a **backpack**, a **tent**, and a **sleeping bag**, along with other camping equipment like a **trail map**, a **compass**, a **water bottle**, and a **pocket knife**. Hiking the whole trail takes an entire season!

*3,478.4 kilometers

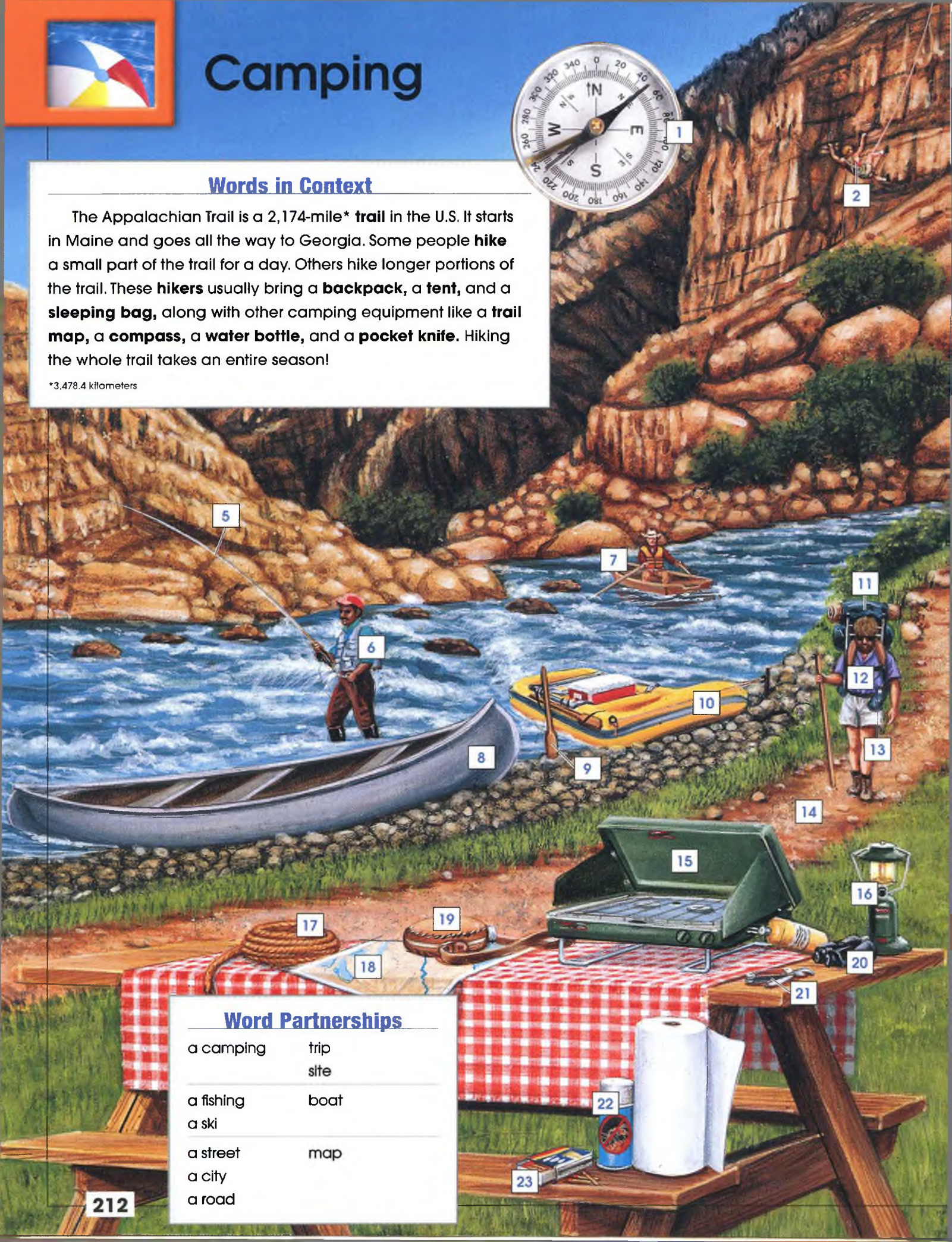

Word Partnerships

- | | |
|-----------|------|
| a camping | trip |
| | site |
| a fishing | boat |
| a ski | |
| a street | map |
| a city | |
| a road | |

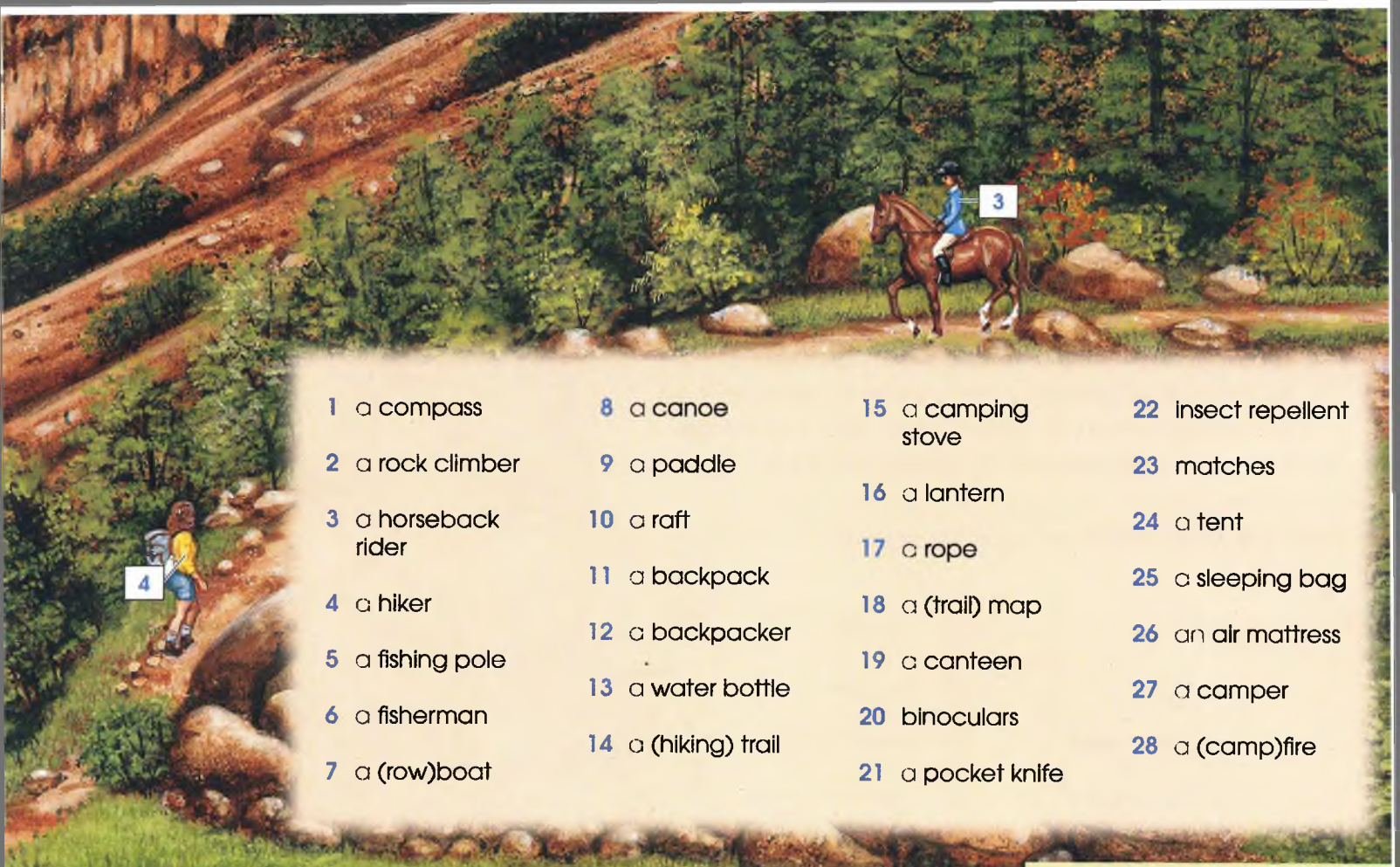

- | | | | |
|---------------------|---------------------|--------------------|---------------------|
| 1 a compass | 8 a canoe | 15 a camping stove | 22 insect repellent |
| 2 a rock climber | 9 a paddle | 16 a lantern | 23 matches |
| 3 a horseback rider | 10 a raft | 17 a rope | 24 a tent |
| 4 a hiker | 11 a backpack | 18 a (trail) map | 25 a sleeping bag |
| 5 a fishing pole | 12 a backpacker | 19 a canteen | 26 an air mattress |
| 6 a fisherman | 13 a water bottle | 20 binoculars | 27 a camper |
| 7 a (row)boat | 14 a (hiking) trail | 21 a pocket knife | 28 a (camp)fire |



Verbs



29 camp



30 fish



31 hike

Words in Action

1. Imagine you are going on a camping trip. What will you do? What will you take?
2. You are lost on a hiking trail. You can only bring five of the items on the list. Which items will you bring? Explain why you need each one.



City Park

Words in Context

Central Park is a beautiful **park** in the middle of New York City. It is about two miles* long and has something for everyone. For adults, there are bicycle and jogging paths. For children, there is a **playground** with a **sandbox**, **monkey bars**, and **swings**. There is even an old **carousel**, an ice rink, and a zoo.

*3.218 kilometers

- | | |
|-------------------------------------|-----------------------|
| 1 a kite | 19 a pond |
| 2 swings | 20 a jogger |
| 3 monkey bars | 21 a skateboard |
| 4 a playground | 22 a skateboarder |
| 5 a slide | 23 a skater |
| 6 a jungle gym | 24 (in-line) skates |
| 7 a seesaw | 25 a cyclist |
| 8 a sandbox | 26 a bicycle / a bike |
| 9 a trash can /
a garbage can | 27 a path |
| 10 a puppet show | 28 a street vendor |
| 11 a picnic | 29 a pigeon |
| 12 a picnic basket | |
| 13 a picnic table | |
| 14 a carousel /
a merry-go-round | |
| 15 a Ferris wheel | |
| 16 a roller coaster | |
| 17 a bridge | |
| 18 a (park) bench | |

Word Partnerships

a local	park
a national	
an amusement	
ride	a bike
	a carousel
have	a picnic
go on	
fly	a kite



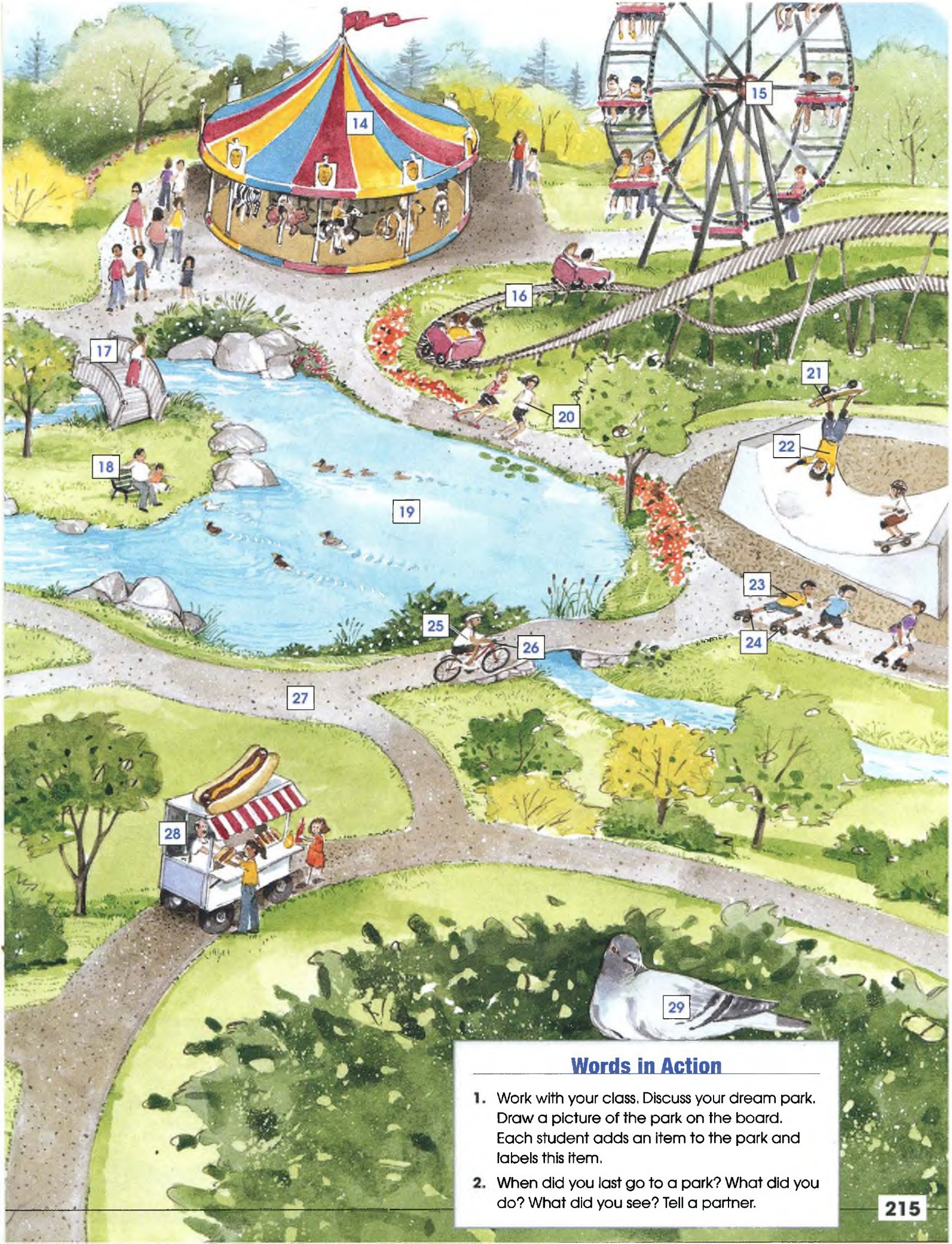

Words in Action

1. Work with your class. Discuss your dream park. Draw a picture of the park on the board. Each student adds an item to the park and labels this item.
2. When did you last go to a park? What did you do? What did you see? Tell a partner.



Places to Visit

Words in Context

Try a new activity this weekend. Do you like shopping? You could go to a flea market or a **garage sale**. Do you enjoy nature? You could walk on a **hiking trail** or ride your bicycle on a **bicycle path**. Do you like animals? You could go to a **zoo** or an **aquarium**.



- 1 a café
- 2 a zoo
- 3 a planetarium
- 4 a nursery
- 5 a bowling alley
- 6 a sporting event
- 7 a pool hall
- 8 an aquarium
- 9 a garage sale
- 10 an amusement park
- 11 a (hiking) trail
- 12 a lecture
- 13 a botanical garden
- 14 a gym
- 15 a circus
- 16 miniature golf
- 17 a bicycle path
- 18 a video arcade
- 19 a carnival
- 20 a museum
- 21 a water park
- 22 a movie theater
- 23 a rodeo





Word Partnerships

a petting	zoo
a traveling	circus
a three-ring	
an outdoor	café
a sidewalk	
an internet	

Words in Action

1. What are your five favorite places to visit from this list? Compare your favorite places with your classmates'. Can you find another student with the same favorite places?
2. Work with a group. Make a list of famous:
 - zoos
 - amusement parks
 - museums



Indoor Sports and Fitness

Words in Context

Different sports and fitness activities help in different ways. **Yoga** and **martial arts** can help you relax. **Aerobics** and the **treadmill** can help you lose weight. **Push-ups** and free weights can help you become stronger.

- | | |
|-------------------------|----------------------|
| 1 martial arts | 21 wrestling |
| 2 yoga | 22 a wrestler |
| 3 basketball | 23 gymnastics |
| 4 a referee | 24 a gymnast |
| 5 a basketball court | 25 weightlifting |
| 6 a (basketball) player | 26 a weightlifter |
| 7 a basketball | 27 a bench |
| 8 ping-pong | 28 a barbell |
| 9 a ping-pong paddle | 29 a dartboard |
| 10 a ping-pong table | 30 darts |
| 11 a chin-up | 31 aerobics |
| 12 a push-up | 32 a diving board |
| 13 a sit-up | 33 a diver |
| 14 a (stationary) bike | 34 a (swimming) pool |
| 15 a treadmill | 35 a locker room |
| 16 boxing | |
| 17 a boxer | |
| 18 a boxing glove | |
| 19 a boxing ring | |
| 20 a punching bag | |

Word Partnerships

- | | |
|----------------|------------|
| sports | club |
| | team |
| | equipment |
| | injury |
| a yoga | instructor |
| an aerobics | class |
| a martial arts | |

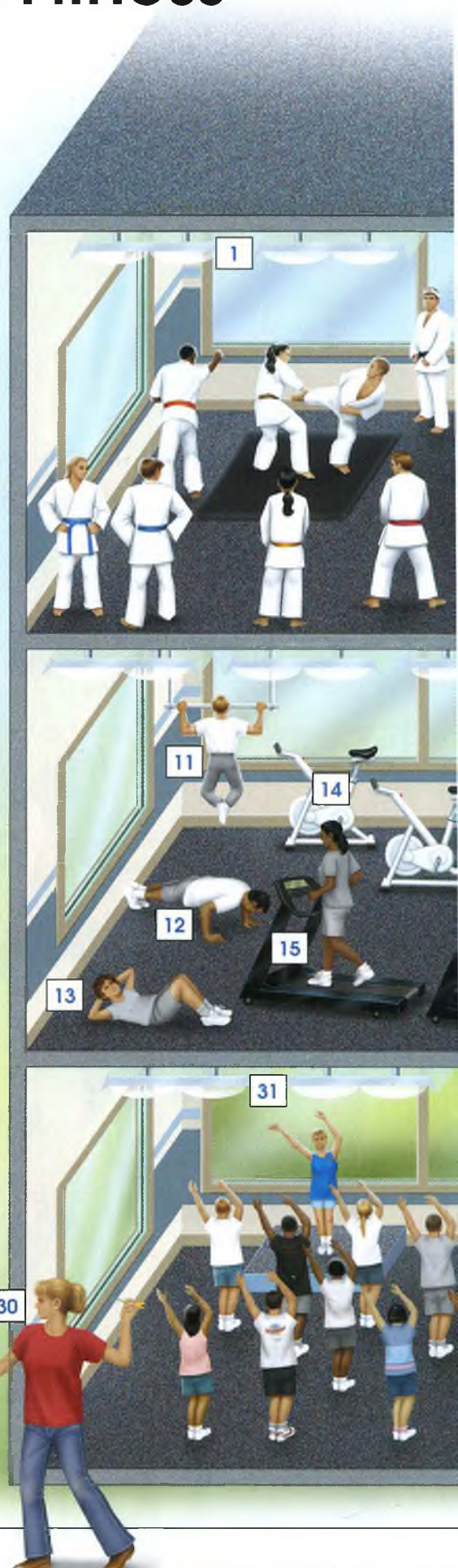

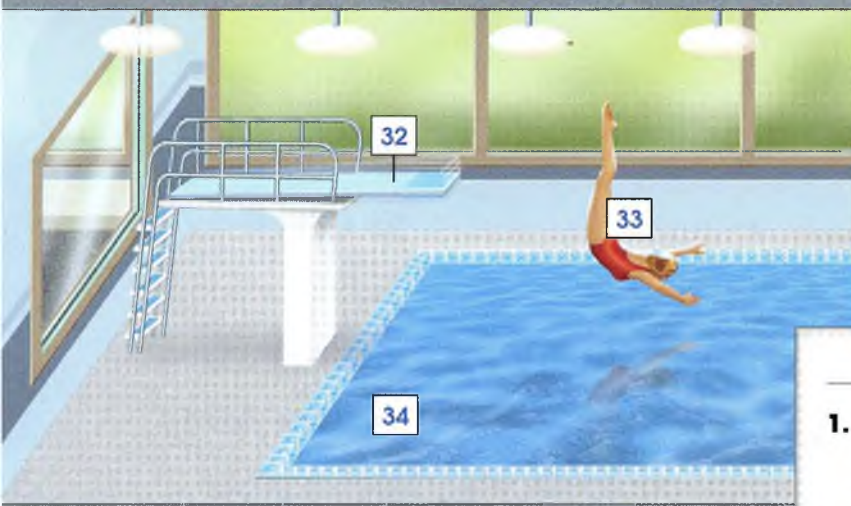
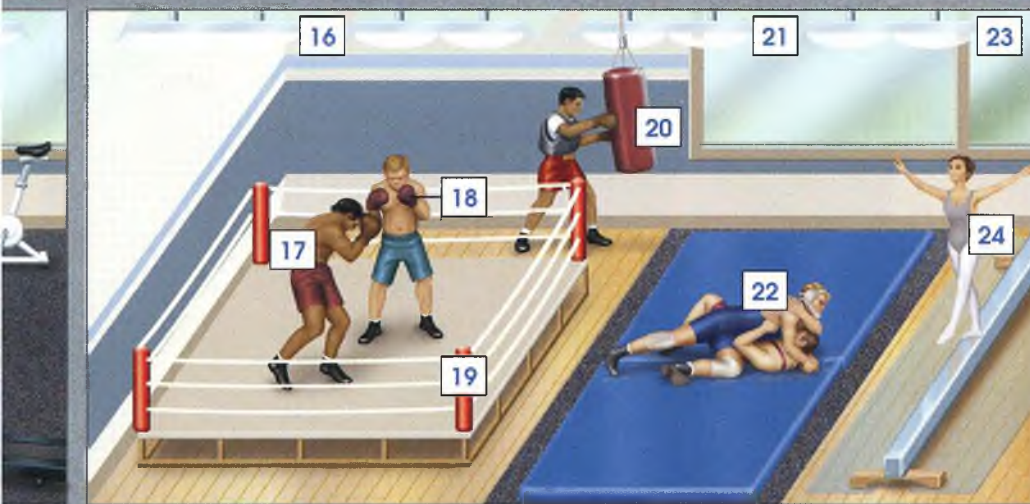
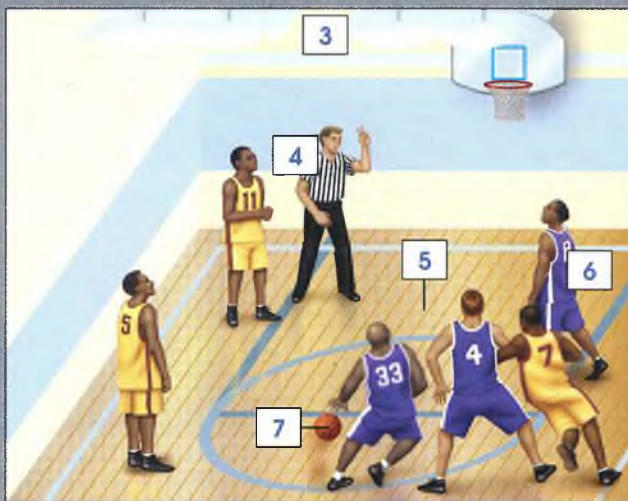

Words in Action

1. Work with a partner. Pretend to do one of the activities on the word list. Your partner will guess the activity. Take turns.
2. What kind of exercise do you do? Discuss with a partner.



Outdoor Sports and Fitness

Words in Context

Tennis is one of the most popular **sports** in the world. The rules are simple. A **player** uses a **racket** to hit a **tennis ball** over the **net**. The other player tries to hit the ball back. The first player to win four points wins the game.

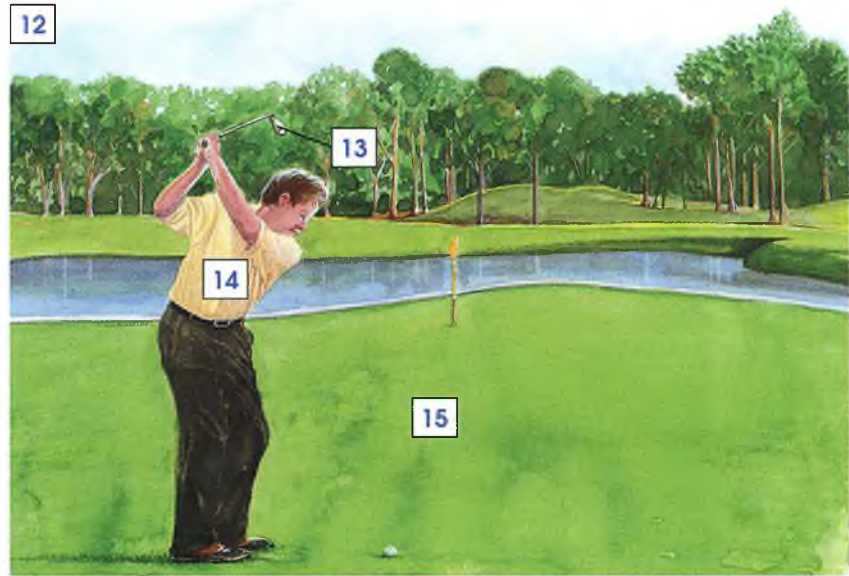
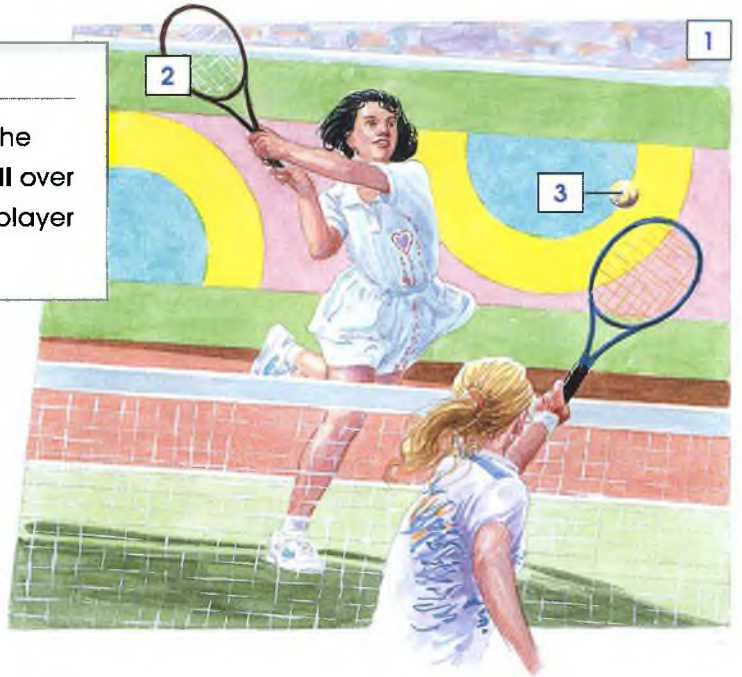

1 tennis

2 a (tennis) racket

3 a (tennis) ball

4 baseball

5 a baseball

6 a batter

7 a bat

8 a catcher

9 volleyball

10 a volleyball

11 a (volleyball) net

12 golf

13 a (golf) club

14 a golfer

15 a golf course

16 track

17 a runner

18 a track

19 soccer

20 a fan

21 a soccer field

22 a uniform

23 football

24 a goalpost

25 a (football) helmet

26 a cheerleader

27 a football

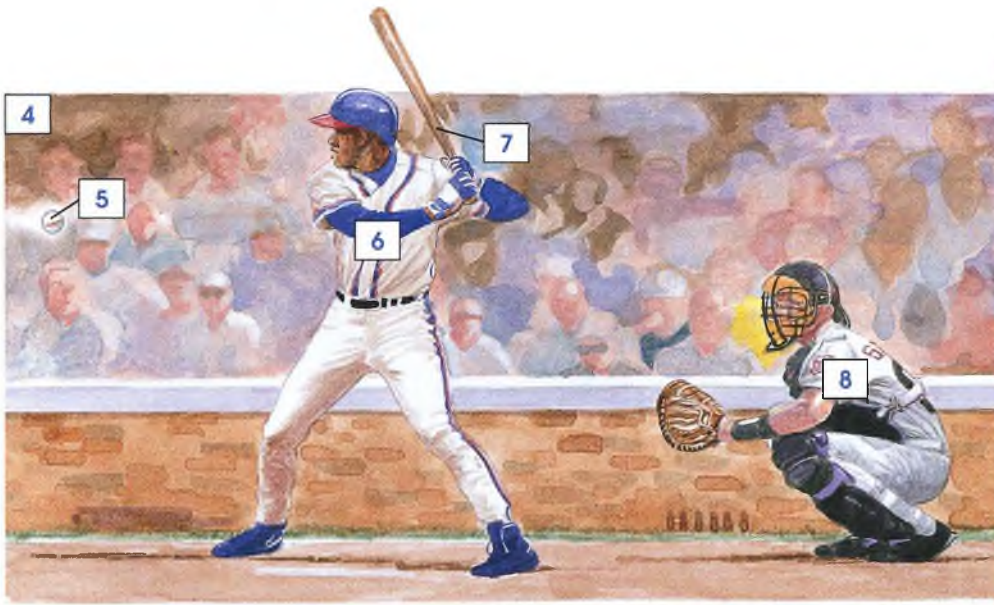

Word Partnerships

a baseball	player
a soccer	
a volleyball	
a rugby	
a golf	ball
a soccer	
a rugby	
hit	the ball
throw	
catch	
kick	
a baseball	glove



Words in Action

- Which of these sports do you like to play? Which do you like to watch? Discuss with a partner.
- Work with a partner. One person pretends to play one of these sports. The other guesses the sport. Take turns.



Winter Sports

Words in Context

Skiing began in Norway in the 1700s. Early **skiers** used long wooden cross-country **skis** and wooden **ski poles**. Today there is a new kind of **winter sport** called **snowboarding**. **Snowboarders** don't use ski poles. They slide down the slopes with both feet on a **snowboard**.

Word Partnerships

a hockey	team
	game
	arena
	rink
a skiing	injury
	lesson



- | | | |
|----------------|------------------|---------------------------|
| 1 a snowmobile | 6 ski poles | 11 (cross-country) skiing |
| 2 snowshoes | 7 a toboggan | 12 (downhill) skiing |
| 3 a sled | 8 a chairlift | 13 a skier |
| 4 skis | 9 ice skating | 14 snowboarding |
| 5 ski boots | 10 an ice skater | 15 a snowboarder |

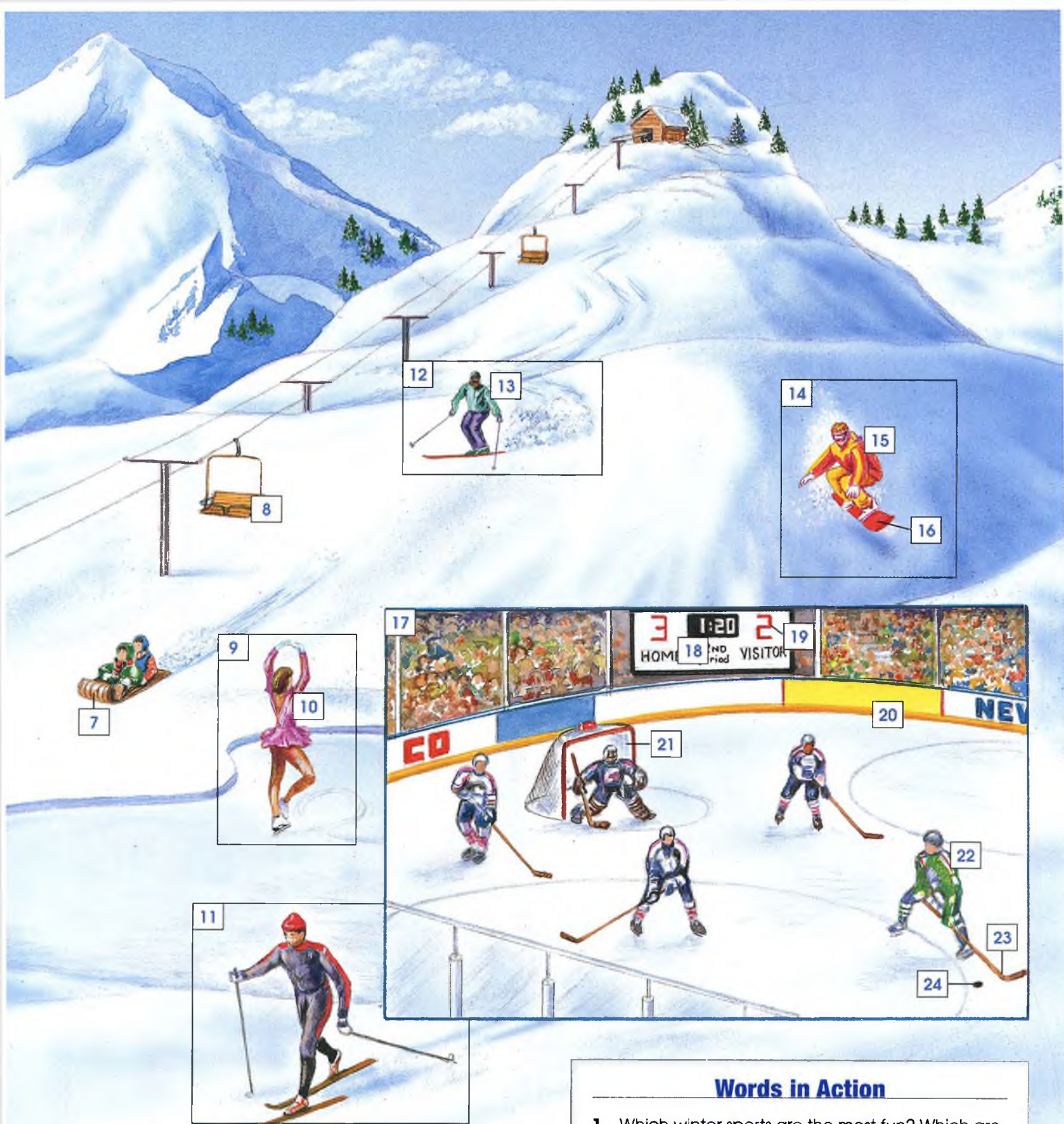

16 a snowboard

21 a goal

17 (ice) hockey

22 a (hockey) player

18 a scoreboard

23 a hockey stick

19 a score

24 a (hockey) puck

20 an ice (skating) rink

25 (ice) skates

Words in Action

- Which winter sports are the most fun? Which are the most dangerous? Discuss with your class.
- One student names a winter sport. The other students take turns naming clothing and equipment for that sport.
 - Student A: *Hockey.*
 - Student B: *Ice skates.*
 - Student C: *A hockey stick.*





Games, Toys, and Hobbies

Words in Context

Playing **cards** are popular in countries around the world. The French style deck is the most common. This deck has 52 cards and four suits—**spades, hearts, diamonds, and clubs**. There are 13 cards in each suit: **ace, king, queen, jack,** and numbers 2 through 10. People use these cards to play different **games** around the world, like *bridge* and *gin rummy* in the U.S., *king* in Brazil, and *dai hin min* in Japan.



- 1 cards
- 2 an ace
- 3 a king
- 4 a queen
- 5 a jack
- 6 a joker
- 7 a spade
- 8 a diamond
- 9 a club
- 10 a heart
- 11 backgammon
- 12 chess
- 13 mah-jongg
- 14 dominoes
- 15 checkers
- 16 a puzzle
- 17 dice
- 18 crayons
- 19 a doll
- 20 knitting needles
- 21 yarn
- 22 a crochet hook
- 23 (embroidery) thread
- 24 a needle

Verbs



25 knit



26 crochet



27 embroider



28 build a model

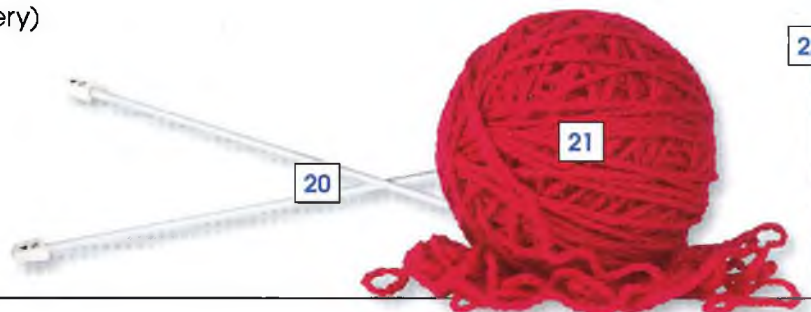

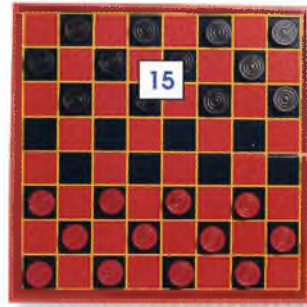
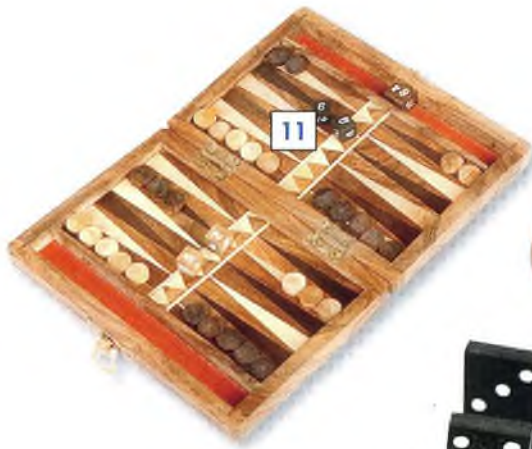

Word Partnerships

a board game

a card

a chess board

a checker piece

a deck of cards

a hand of

play cards
 a game

king of hearts

nine of spades



24

Words in Action

1. Make a list of your three favorite games from the list. Put the list in order, with the game you like best at the top. Share your list with a partner.
2. Take a poll to find out the favorite games of the students in your class.
 - ☒ Which is the most popular game?
 - ☒ Which is the least popular game?



Camera, Stereo, and DVD

Words in Context

Audio equipment keeps changing. Until the 1980s, most people listened to music on **records** or **tapes**. Then in 1983, **CD players** and **CDs** became available. By 1998, more people bought CDs than records. By the late 1990s, MP3 technology became popular. Now **MP3 players** are becoming one of the most popular items at electronics stores.



- 1 (a roll of) film
- 2 a zoom lens
- 3 a camera
- 4 a camcorder
- 5 a tripod
- 6 a plug
- 7 an adapter (plug)
- 8 a record
- 9 an MP3 player
- 10 a (personal) CD player
- 11 headphones
- 12 a CD player
- 13 a CD / a compact disc
- 14 a speaker
- 15 a stereo (system)
- 16 a tape / a cassette
- 17 a boom box
- 18 a satellite dish
- 19 a television / a TV
- 20 a (video) game system



- 21 a VCR / a videocassette recorder
- 22 a video(cassette)
- 23 a remote control
- 24 a DVD player
- 25 a DVD

Word Partnerships

a digital	camera
a 35-millimeter	
a disposable	
shoot	(a roll of) film
develop	
turn up	the TV
turn down	the stereo

Verbs



26 play



27 fast forward



28 rewind



29 pause



30 stop



31 eject



Words in Action

1. Which three items on the list would you most like to get as gifts? Why? Discuss with a partner.
2. Which items on the list could help you learn English? How? Discuss with your class.



Holidays and Celebrations

Words in Context

People celebrate the **New Year** in different ways around the world. In Brazil, many people have **parties**. They often go to the beach after midnight and watch **fireworks**. It is also traditional to throw **flowers** into the sea. The Chinese New Year happens between January 17 and February 19. Chinese people all over the world celebrate with **parades** and **firecrackers**.

1

2



4

5

6



7

8



10

11

12



13

14

15



16

17

18



19

21

22



20

1 New Year

2 a firecracker

3 a parade

4 Valentine's Day

5 chocolates

6 a card

7 Independence Day

8 fireworks

9 a barbeque

10 Mother's Day

11 a gift / a present

12 flowers

13 Halloween

14 a costume

Verbs



29 wrap
a present



30 light
candles



31 blow out
candles



32 open
a present



15 a jack-o-lantern

16 Thanksgiving

17 a turkey

18 a pumpkin pie

19 Christmas

20 Santa Claus

21 lights

22 a (Christmas) tree

23 a birthday

24 a balloon

25 a cake

26 an anniversary

27 a baby shower

28 a retirement

Word Partnerships

a birthday party

a retirement

a New Year's Eve

a birthday gift

a wedding cake

a birthday card

a Valentine's Day

a Mother's Day

Words in Action

1. Work with a group. Choose a holiday on the list. What are the different ways the people in your group celebrate this holiday? Discuss with your group.
2. Plan a birthday party for a friend.
 - What will you eat?
 - How will you decorate?
 - What gift will you give?

Index

Index Guide

All entries in the index are followed by a phonetic listing. Following the phonetic listing, most entries have two numbers. The first number, in bold type, is the page number on which the entry item is found. The second number corresponds to the item's number in the word list. See the example below.



Some entries have two numbers in bold type. In this case, the entry is a topic covered in a two-page lesson, and the numbers indicate the page numbers of this lesson.

If the entry is in capital letters, it is a unit title, and the two numbers in bold type indicate the pages on which this unit begins and ends.

If an entry is followed by only a single number in bold type, then the entry appears on this page number as a subhead in the word list, or it appears somewhere else on the page.

Verb and verb phrase entries appear in bold type in the index. Some entries appear twice in the index—once in bold and once in regular type. In these cases, the bold type entry is a verb, and the regular type entry is a noun.

Guide to Pronunciation Symbols

Vowels

Symbol	Key Word	Pronunciation
/ɑ/	hot	/hɑt/
	far	/fɑr/
/æ/	cat	/kæt/
/aɪ/	fine	/faɪn/
/aʊ/	house	/haʊs/
/ɛ/	bed	/bɛd/
/eɪ/	name	/neɪm/
/i/	need	/ni:d/
/ɪ/	sit	/sɪt/
/oʊ/	go	/goʊ/
/ʊ/	book	/bʊk/
/u/	boot	/bu:t/
/ɔ/	dog	/dɔg/
	four	/fɔr/
/ɔɪ/	toy	/tɔɪ/
/ʌ/	cup	/kʌp/
/ɛr/	bird	/bɛrd/
/ə/	about	/ə'baʊt/
	after	/'æftər/

Consonants

Symbol	Key Word	Pronunciation
/b/	boy	/bɔɪ/
/d/	day	/deɪ/
/dʒ/	just	/dʒʌst/
/f/	face	/feɪs/
/g/	get	/get/
/h/	hat	/hæt/
/k/	car	/kɑr/
/l/	light	/laɪt/
/m/	my	/maɪ/
/n/	nine	/naɪn/
/ŋ/	sing	/sɪŋ/
/p/	pen	/pen/
/r/	right	/raɪt/
/s/	see	/si/
/t/	tea	/ti/
/tʃ/	cheap	/tʃi:p/
/v/	vote	/voʊt/
/w/	west	/west/
/y/	yes	/yes/
/z/	zoo	/zu/
	they	/ðeɪ/
	think	/θɪŋk/
	shoe	/ʃu/
	vision	/'vɪʒən/

Stress

/ˈ/	city	/'sɪti/	used before a syllable to show primary (main) stress
-----	------	---------	--

aardvark /'ɑ:rd,vɑ:k/ 182-14
 above /'ə'baʊ/ 13-10
 absence note /'æbsəns nout/ 23-27
 accelerator /'ɪk'selə'reitər/ 121-27
 accessories /'ɪk'sesəriz/ 108-109
 accident /'æksədənt/
 have an... /hæv ən/ 123-19
 accordion /æ'kɔ:rdiən/ 207-28
 accountant /ə'kaʊntnt/ 146-1
 ace /eis/ 224-2
 acid rain /'æsid rein/ 171-14
 acne /'ækni/ 135-22
 across /ə'krɔ:s/ 130-17
act /ækt/ 150-10
 action /'æksjən/ 208-1
 actor /'æktər/ 147-25, 205-18
 acupuncture /'ækjə,pʌŋkɪfər/ 141-3
 acupuncturist /'ækjə,pʌŋkɪfərist/ 141-4
 adapter (plug) /ə'dæptər (plʌg)/ 226-7
add /æd/ 92-4
 addition /ə'dɪʃən/ 193-26
address /ə'dres/ 53-21
 address /'ə'dres/ 42
 mailing... /'meɪlɪŋ/ 52-6
 return... /rɪ'tɜ:n/ 52-4
 adhesive bandage /əd'hɪsɪv 'bændɪdʒ/ 143-28
 adult /ə'dʌlt/ 30
 adventure /əd'ventʃər/ 208-1
 aerobics /e'roubɪks/ 218-31
 afraid /ə'freɪd/ 39-19
 Africa /'æfrɪkə/ 174-12
 afternoon /,æftər'nun/ 5
 aftershave /'æftərʃeɪv/ 144-17
agree /ə'gri/ 40-11
 air bag /er bæɡ/ 121-10
 air conditioner /er kən'dɪʃənər/ 67-14
 air conditioning /er kən'dɪʃənɪŋ/ 121-19
 air mattress /er 'mætrɪs/ 213-26
 airplane /'eɪpleɪn/ 125
 air pollution /er pə'lju:ʃən/ 171-13
 airport /'eɪpɔ:rt/ 124-125
 aisle /aɪl/ 99-13, 125-29
 alarm clock /ə'lɑ:m klɒk/ 74-9
 algebra /'ælʒəbrə/ 193-32
 alive /ə'lɑ:ɪv/ 14-11
 allergic reaction /ə'lɜ:dʒɪk rɪ'ækʃən/
 have an... /hæv ən/ 136-12
 alligator /'ælɪgətər/ 182-18
 almonds /'ʌməndz/ 83-31
 along /ə'lɔŋ/ 130-18
 alphabet /'ælfəbet/ 19-1
 ambulance /'æmbyələns/ 118-27, 139-29
 American /ə'merɪkən/ 44-2
 amusement park /ə'mju:zmənt pɑ:k/ 216-10
 anchor /'æŋkər/ 163-18
 anesthesiologist /ænəsθi:zɪ'ælədʒɪst/ 138-7
 angelfish /'eɪnʒəlɪʃ/ 189-23
 angle /'æŋɡəl/ 193-9
 angry /'æŋɡri/ 38-3
 animals /'ænəməlz/ 153
ANIMALS, PLANTS, AND HABITATS
 /'ænəməlz, plænts, ənd 'hæbətəts/ 178-191
 animated /'ænəmeɪtəd/ 208-11
 ankle /'æŋkəl/ 133-15
 swollen... /'swʊlənd/ 135-11
 anniversary /,æno'vɜ:səri/ 229-26
answer /'ænsər/ 17-27
 answering machine /'ænsərɪŋ mə'ʃɪn/ 16-18
 ant /'ænt/ 181-24
 antacid /ænt'æsid/ 142-8

Antarctica /ænt'ɑ:ktɪkə/ 174-14
 Antarctic Circle /ænt'ɑ:ktɪk 'sɜ:kəl/ 174-4
 antelope /'æntləʊp/ 185-9
 antenna /æn'tenə/ 16-21
 antibacterial cream /æntɪbæk'tɪriəl kɪm/ 143-29
 antibacterial ointment /æntɪbæk'tɪriəl 'ɔɪntmənt/ 143-29
 antihistamine /,æntɪ'hɪstə'mɪn/ 142-14
 antler /'æntlər/ 185-21
 ants /'ænts/ 76-23
 apartment /ə'pɑ:tmənt/ 63-9
 decorate the... /'deko'reɪt ði/ 64-13
 look for an... /lʊk fər ən/ 64-1
 rent an... /rent ən/ 31-7
 studio... /'stɪdiu/ 67-9
 see the... /si ði/ 64-4
 apartment building /ə'pɑ:tmənt 'bɪldɪŋ/ 66-67
apologize /ə'pɒlədʒaɪz/ 40-9
 apostrophe /ə'pɒstrəfi/ 196-14
 appetizer /'æpə'taɪzər/ 101-26
applaud /ə'plɒd/ 204-26
 apple /'æpəl/ 83-11
 apple juice /'æpəl dʒus/ 88-28
 apples /'æpəlz/
 basket of... /'bæskɪt əv/ 97-31
apply for /ə'plɑɪ fər/ 65-22
 appointment /ə'pɔɪntmənt/
 make an... /meɪk ən/ 64-2, 137-21
 appointment book /ə'pɔɪntmənt bu:k/ 155-14
 apricot /'æprɪkət/ 83-16
 April /'eɪprəl/ 7-19
 apron /'eɪprən/ 101-3
 aquarium /ək'wɛəriəm/ 216-8
 architect /'ɑ:kɪtekt/ 146-19
 Arctic Circle /'ɑ:ktɪk 'sɜ:kəl/ 174-2
 area code /'eəriə kɔ:d/ 16-22
 Argentine /'ɑ:rdʒəntɪn/ 44-9
 Argentinean /ɑ:rdʒən'tɪniən/ 44-9
argue /'ɑ:ɡju/ 40-1
 arm /ɑ:m/ 133-8
 armchair /'ɑ:m,tʃeə/ 72-3
 armed robbery /ɑ:md 'rɒbəri/ 61-14
 around /ə'raʊnd/ 13-12, 130-9
arrange /ə'reɪndʒ/ 64-12
arrest /ə'rest/ 150-4
 arrest /ə'rest/ 61-15
 arrival and departure monitors
 /ə'raɪvəl ənd dɪ'pɑ:tʃər 'mɒnətəz/ 125-11
arrive at /ə'raɪv/ 123-24
 arson /'ɑ:sən/ 61-7
 art gallery /ɑ:t 'ɡæləri/ 58-3
 arthritis /ɑ:'θraɪtɪs/ 135-16
 artichoke /'ɑ:tə,tʃo:k/ 84-13
 artist /'ɑ:tɪst/ 146-3
 graphic... /'ɡræfɪk/ 146-7
THE ARTS /ðə ɑ:ts/ 202-209
 Asia /'eɪʒə/ 174-11
ask /æsk/ 64-5
ask for /æsk fər/
 ...a pillow /ə 'pɪləʊ/ 126-14
 ...directions /də'rekʃənz/ 123-4
 ...the check /ðə tʃek/ 102-17
 asparagus /ə'spærəɡəs/ 84-3
 aspirin /'æsprɪn/ 143-27
 assembler /ə'semblər/ 146-18
 assembly line /ə'sembli laɪn/ 156-3
 asthma /'æzmə/ 135-2
 astronaut /'æstrənɔ:t/ 176-14
 astronomer /ə'strɒnəmər/ 176-10
 athletic shoe /æθ'letɪk ʃu/ 109-23
 athletic supporter /æθ'letɪk sə'pɔ:tər/ 107-28

Atlantic Provinces /ət'læntɪk 'prævɪnsəz/ 172-6
 atlas /'ætləs/ 55-15
 ATM /'eɪtɪəm/ 51-20
 ATM card /'eɪtɪəm kɑrd/ 51-22
 insert your... /ɪn,ʃɜrt jər/ 51-24
 atmosphere /'ætmosfɪr/
 Earth's... /ɜrθs/ 176-15
 atom /'ætəm/ 194-17
 attendant /ə'tendənt/ 146-21
 attic /'ætɪk/ 69-2
 attorney /ə'tɜrni/ 61-24
 audience /'ɔdiəns/ 204-9
 auditorium /,ɔdɔ'tɔriəm/ 23-18
 August /'ɔgəst/ 7-23
 aunt /ænt/ 27-3
 Australia /ɔs'treɪljə/ 174-13
 Australian /ɔs'treɪljən/ 44-30
 author /'ɔθər/ 55-21
 autobiography /,ɔtəbaɪ'agrəfi/ 55-24
 automated check-in machine /'ɔtəmeɪtəd tʃek-ɪn 'məʃɪn/
 124-7
 automobile exhaust /,ɔtəmə'bil ɪg'zɔst/ 171-20
 auto theft /'ɔtə θeft/ 61-1
 autumn /'ɔtəm/ 7-14
 avalanche /'ævə,læntʃ/ 171-7
 avocado /,avə'kədou/ 83-10
 ax /æks/ 160-5
 baby /'beɪbi/ 30, 56-32
 baby animals /'beɪbi 'ænəməlz/ 153
 baby carrier /'beɪbi 'kæriər/ 57-9
 baby lotion /'beɪbi 'ləʊʃən/ 57-23
 baby powder /'beɪbi 'paʊdər/ 57-22
 baby shower /'beɪbi 'ʃaʊər/ 229-27
 babysitter /'beɪbi,sɪtər/ 147-30
 baby swing /'beɪbi swɪŋ/ 57-6
 baby wipes /'beɪbi wɪps/ 57-24
 back /bæk/ 133-22
 backache /'bækəɪk/ 135-17
 backgammon /'bæk,gæməŋ/ 224-11
 backhoe /'bækhou/
 operate a... /'apə,reɪt ə/ 165-15
 backpack /'bæk,pæk/ 23-15, 213-11
 backpacker /'bæk,pækər/ 213-12
 backup singers /'bæk,ʌp 'sɪŋərz/ 205-16
 bacon /'beɪkən/ 88-20
 broil... /brɔɪl/ 92-9
 bag /bæg/
 carry a... /'kæri ə/ 165-18
 ...of potatoes /ʌv pə'tetɪtəʊz/ 97-22
 bagel /'beɪgəl/ 90-5
 baggage /'bæɡɪdʒ/ 124-5
 check your... /tʃek jər/ 126-3
 baggage claim (area) /'bæɡɪdʒ kleɪm (ˈeɪrɪə)/ 125-19
 bagger /'bæɡər/ 99-18
 baggy /'bæɡi/
 ...pants /pænts/ 111-12
 bags /bægz/
 claim your... /kleɪm jər/ 126-24
bake /beɪk/ 93-31
 baked potato /beɪkd pə'tetɪtəʊ/ 90-9
 bakery /'beɪkəri/ 48-22, 99-5
 balance /'bæləns/ 51-18, 194-9
 balcony /'bælkəni/ 67-16, 204-2
 bald /bɔld/ 33-14
 ball /bɔl/
 tennis... /'tenɪs/ 220-3
 ballet /bæl'eɪ/ 204-1
 balloon /bə'lun/ 229-24
 ballot /'bælət/ 200-2
 ballroom /'bɔl,rʊm/ 159-8

banana /bə'nænə/ 83-29
 bandage /'bændɪdʒ/
 adhesive... /əd'hɪsɪv/ 143-28
 bangs /bæŋz/ 33-23
 banjo /'bæŋdʒəʊ/ 207-23
 bank /bæŋk/ 50-51, 58-2
 bankcard /'bæŋk,kɑrd/ 51-22
 bank manager /'bæŋk 'mænɪdʒər/ 51-8
 bar /bɑr/
 ...of soap /ʌv sɒp/ 97-8
 barbecue /'bɑrbi,kju/ 69-6
 barbell /'bɑr,bel/ 218-28
 barbeque /'bɑrbi,kju/ 228-9
 barber /'bɑrbər/ 146-17
 barbershop /'bɑrbər,ʃɑp/ 48-12
 bar code /bɑr kəʊd/ 9-21
 barcode scanner /'bɑrkəʊd 'skænər/ 99-19
 barn /bɑrn/ 152-3
 barrette /bə'ret/ 144-7
 baseball /'beɪs,bɔl/ 220-4
 baseball /'beɪs,bɔl/ 220-5
 baseball cap /'beɪs,bɔl kæp/ 109-27
 baseball hat /'beɪs,bɔl hæʔ/ 109-27
 basement /'beɪsmənt/ 67-7, 77-9
 BASIC WORDS /'beɪsɪk wɜrdz/ 2-27
 basket /'bæskɪt/ 97-31
 basketball /'bæskɪt,bɔl/ 218-3, 218-7
 basketball court /'bæskɪt,bɔl kɔrt/ 218-5
 basketball player /'bæskɪt,bɔl 'pleɪər/ 218-6
 bass (fish) /bæs/ 189-15
 bass (instrument) /beɪs/ 207-19
 bassoon /bə'sun/ 207-15
baste /beɪst/ 92-16
 bat /bæt/ 182-4, 220-7
 bath /bæθ/
 take a... /teɪk ə/ 34-22
bathe /beɪð/ 29-7
 bathing suit /'beɪðɪŋ sɪt/ 107-7
 bathrobe /'bæθ,rəʊb/ 107-13
 bathroom /'bæθ,rʊm/ 23-10, 74-75
 bathtub /'bæθ,tʌb/ 75-22
 batter /'bætər/ 220-6
 battery /'bætəri/ 121-33, 163-33
 bay /beɪ/ 169-25
be /bi/
 ...a single mother /ə 'sɪŋɡəl 'mʌðər/ 27-29
 ...divorced /dɪ'vɔrsd/ 26-28
 ...in pain /ɪn peɪn/ 136-1
 ...in shock /ɪn ʃək/ 136-4
 ...married /'mæriəd/ 26-27
 ...online /,ɔn'laɪn/ 24-30
 ...pregnant /'preɡnənt/ 31-14
 ...remarried /rɪ'mæriəd/ 27-30
 ...unconscious /ʌn'kɔnʃəs/ 136-2
 beach /bi:tʃ/ 169-23, 210-211
 beach ball /'bi:tʃ bɔl/ 211-20
 beak /bi:k/ 187-20
 beaker /'bi:kər/ 194-23
 beans /bi:nz/ 91-28
 bean sprouts /bi:n sprəʊts/ 84-20
 bear /ber/
 grizzly... /'grɪzli/ 187-5
 polar... /'pəʊlər/ 187-8
 bear cub /ber klʌb/ 187-9
 beard /bɜrd/ 33-16
beat /bit/ 93-27
 beautiful /'byutəfəl/ 14-14
 beauty salon /'byuti sə'lɔn/ 48-11
 beaver /'bi:vər/ 190-15
be born /'bi bɔrn/ 31-1

become /bi'kʌm/
 ...a grandparent /ə 'grænd,perənt/ 31-21
bed /bed/ 74-14
 go to... /gou tə/ 34-23
 make the... /meik ðə/ 79-1
bedpan /'bed,pæn/ 139-19
bedroom /'bed,rʊm/ 74-75
bedspread /'bed,spred/ 74-17
bee /bi/ 185-1
beef /bif/ 86
bee sting /bi stɪŋ/ 135-28
beetle /'bitl/ 182-24
beets /'bits/ 84-2
behave /br'heiv/ 29-24
behind /br'hænd/ 13-14, 130-6
belge /beɪʒ/ 10-17
bellhop /'bel,hɒp/ 159-15
bell pepper /bel 'pepə/ 84-23
below /br'lou/ 13-13
belt /belt/ 109-6
 tool... /tu:l/ 160-12
bench /bentʃ/ 72-1, 218-27
 park... /pɑ:k/ 214-18
beside /br'saɪd/ 13-11
between /br'twi:n/ 13-4, 130-8
beverages /'bevri:dʒəz/ 99-11
bib /bɪb/ 57-16
bicycle /'baɪsɪkəl/ 214-26
bicycle path /'baɪsɪkəl pæθ/ 216-17
big /bɪg/ 14-2
bike /baɪk/ 214-26
 stationary... /'steɪʃə,neri/ 218-14
 bikini /br'ki:ni/ 107-8
bill /bɪl/ 52-1, 101-31
billboard /'bɪl,bɔ:d/ 58-9
bills /'brɪlz/ 8
 pay the... /peɪ ðə/ 79-6
binder /'baɪndər/ 155-2
binoculars /bɪ'nɒkjələz/ 213-20
biography /baɪ'agrəfi/ 55-23
biohazard /'baɪəʊ'hæzəd/ 156-30
biologist /baɪ'ələdʒɪst/ 194-2
biology /baɪ'ələdʒi/ 194-1
birch (tree) /bɜ:ʃ (tri)/ 179-3
birth certificate /bɜ:θ sər'tɪfɪkət/ 43-24
birthday /'bɜ:θ,deɪ/ 229-23
 celebrate a... /'selə,breɪt ə/ 31-20
black /blæk/ 10-22
blackboard /'blæk,bɔ:d/ 19-6
blackboard eraser /'blæk,bɔ:d ɪ'reɪsər/ 19-4
black hair /blæk heə/ 33-3
blade /bleɪd/ 161-30
blanket /'blæŋkɪt/ 74-2
blanket sleeper /'blæŋkɪt 'slɪpər/ 107-16
bleach /bli:tʃ/ 116-5
bleachers /'bli:tʃəz/ 23-5
bleed /bli:d/ 136-3
blender /'blendər/ 70-12
blind /blaɪnd/ 135-18
blinds /blaɪndz/ 72-19
blister /'blɪstər/ 135-25
blizzard /'blɪzəd/ 171-2
blond hair /blɒnd heə/ 33-4
blood /blʌd/ 138-9
 draw... /drɔ:/ 137-24
blood pressure /blʌd 'preʃər/
 check... /tʃek/ 137-23
blood pressure monitor /blʌd 'preʃər 'mɒnətər/ 141-19
bloody nose /'blʌdi noʊz/ 135-29
blouse /blaʊs/ 104-14

blow dryer /'blou,draɪər/ 144-6
blow out /'blou aʊt/
 ...canals /'kændls/ 229-31
blue /blu/ 10-9
 ...navy /'neɪvi/ 10-11
blueberries /'blu,berɪz/ 83-17
blue jay /blu dʒeɪ/ 190-4
blue jeans /blu dʒi:nz/ 104-27
blueprints /'blu,prɪntz/
 read... /rɪd/ 165-17
blues /bluz/ 209-25
blush /blʌʃ/ 144-28
board /bɔ:d/ 126-8
board /bɔ:d/
 black... /blæk/ 19-6
 bulletin... /'bʊlətɪn/ 19-7
 erase the... /ɪ'reɪs ðə/ 20-17
 go to... /gou tu/ 20-16
 white... /waɪt/ 19-14
boarding pass /'bɔ:dɪŋ pæs/ 124-8
board lumber /bɔ:d 'lʌmbər/ 163-30
boat /bəʊt/ 213-7
bobcat /'bɒb,kæt/ 190-6
boil /bɔɪl/ 92-17
bolt /bəʊlt/ 163-21
bone /bəʊn/ 133-3
book /bʊk/ 19-11
 appointment... /ə'pɔɪntmənt/ 155-14
 close your... /kləʊz jər/ 20-9
 date... /deɪt/ 155-14
 look for a... /lʊk fər ə/ 54-26
 open your... /'ɒpən jər/ 20-10
 share a... /ʃeə ə/ 21-21
bookcase /'bʊk,keɪs/ 72-22
books /bʊks/
 check out... /tʃek aʊt/ 54-27
 return... /rɪ'tɜ:n/ 55-29
bookshelf /'bʊkʃelf/ 19-10
bookstore /'bʊkstɔ:r/ 48-9
boom box /bəʊm bɒks/ 226-17
boot /bu:t/ 109-25
boots /bu:ts/
 safety... /'seɪfti/ 157-28
bored /bɔ:d/ 39-13
botanical garden /bɒ'tænəkəl 'gɑ:dn/ 216-13
bottle /'bɒtl/ 57-2
 ...of olive oil /ɒv 'ɒlɪv oɪl/ 97-7
bottled water /'bɒtld 'wɔ:tər/ 88-15
bottle opener /'bɒtl 'ɒpənər/ 94-15
boulder /'bəʊldər/ 181-3
bouquet /'bu:kweɪ/ 97-6
bow /bəʊ/ 40-14, 204-27
bow /'bəʊl/ 70-24, 101-14
bowling alley /'bəʊlɪŋ 'æli/ 216-5
box /bɒks/ 97-20
boxer /'bɒksər/ 218-17
boxers /'bɒksəz/ 107-26
boxer shorts /'bɒksər ʃɔ:ts/ 107-26
boxing /'bɒksɪŋ/ 218-16
boxing glove /'bɒksɪŋ 'glʌv/ 218-18
boxing ring /'bɒksɪŋ rɪŋ/ 218-19
box office /'bɒks 'ɒfɪs/ 205-24
boy /bɔɪ/ 57-14
bra /brə/ 107-19
bracelet /'breɪslɪt/ 109-10
braces /'breɪsəz/ 141-29
braids /breɪdz/ 33-21
brain /breɪn/ 133-24
brainstorm /'breɪn,stɔ:rm/ 196-20
brake light /breɪk laɪt/ 121-6

- brake pedal /breik 'pedl/ 121-26
branch /bræntʃ/ 179-10
brass /bræs/ 207
Brazilian /brə'zi:ljən/ 44-7
bread /bred/
 butter the... /'bʌtər ðə/ 102-8
 loaf of... /louf əv/ 97-16
break /breik/
 ...a leg /ə leg/ 136-5
break /breik/
 take a... /teik ə/ 20-14
breaker panel /'breikər 'pænl/ 77-12
breakfast /'brekfæst/
 eat... /it/ 34-9
 have... /hæv/ 34-9
breast /brest/ 133-10
bribery /'braibəri/ 61-2
bricks /'briks/
 lay... /lei/ 165-5
bridge /brɪdʒ/ 214-17
briefcase /'brɪfkeɪs/ 109-16
briefs /brɪfs/ 107-27
British /'brɪtɪʃ/ 44-10
British Columbia /'brɪtɪʃ kə'lʌmbiə/ 172-2
broccoli /'brækəli/ 84-1
 steam... /stim/ 92-10
broil /brɔɪl/ 92-9
broken /'brəʊkən/ 77-10
broom /brʊm/ 80-28
brother /'brʌðər/ 27-17
brother-in-law /'brʌðər-ɪn-ˌlɔ/ 27-14
brown /braʊn/ 10-16
brown hair /braʊn heə/ 33-2
bruise /brʊz/ 135-30
brush /brʌʃ/ 34-3
brush /brʌʃ/
 hair... /heə/ 144-10
bucket /'bʌkɪt/ 80-16
buckle /'bʌkəl/ 114-11
bud /'bʌd/ 179-17
buffalo /'bʌfələʊ/ 185-17
bugle /'byʊgəl/ 207-10
bug spray /bʌg spreɪ/ 80-15
build /bɪld/ 198-3, 224-28
building material /'bɪldɪŋ mə'tɪrɪəl/ 162
bulb /bʌlb/ 179-18
bull /bʊl/ 152-7
bulletin board /'bʊlətɪn bɔ:d/ 19-7
bumper /'bʌmpər/ 121-9
bun /bʌn/ 33-22
bunch /'bʌntʃ/
 ...of carrots /əv 'kærəts/ 97-29
Bunsen burner /'bʌnsən 'bɜ:nər/ 194-14
burglary /'bɜ:gləri/ 61-3
burn /'bɜ:n/ 136-6
burn /'bɜ:n/ 135-24
burned out /'bɜ:nd aʊt/ 77-6
burrito /be'ritoʊ/ 91-25
bus /bʌs/ 102-25
bus /bʌs/ 128-9
busboy /'bʌs,bɔɪ/ 101-5
bus driver /'bʌs 'draɪvər/ 128-8
bush /bʊʃ/ 185-16
 lilac... /'laɪ,læk/ 179-7
business card /'bɪznɪs kɑ:d/ 43-20
business card file /'bɪznɪs kɑ:d faɪl/ 155-15
business center /'bɪznɪs 'sentər/ 159-7
businessman /'bɪznɪs,mæn/ 146-23
business suit /'bɪznɪs su:t/ 104-29
businesswoman /'bɪznɪs,wʊmən/ 146-23
busser /'bʌsər/ 101-5
bus stop /bʌs stɒp/ 128-7
butcher /'bʊtʃər/ 146-20
butter /'bʌtər/ 102-8
butter /'bʌtər/ 88-23
butterfly /'bʌtər,flaɪ/ 182-21
buttocks /'bʌtəks/ 133-47
button /'bʌtn/ 114-10
button /'bʌtn/ 117-15
button-down /'bʌtn-ˌdaʊn/
 ...shirt /ʃɜ:t/ 111-6
buttonhole /'bʌtn,həʊl/ 117-14
buy /baɪ/ 114-5
 ...a house /ə haʊs/ 31-13
buying a house /'baɪ,ɪŋ ə haʊs/ 65
buying clothes /'baɪ,ɪŋ kləʊz/ 114-115
cab /kæb/ 128-4
cabbage /'kæbɪdʒ/ 84-8
cab driver /'kæb 'draɪvər/ 128-5
cabin /'kæbɪn/
 log... /lɒg/ 63-4
cabinet /'kæbənɪt/ 70-2
 file... /faɪl/ 155-18
 supply... /sə'plaɪ/ 155-22
cable /'keɪbəl/ 25-11
cactus /'kæktəs/ 181-16
café /kæ'feɪ/ 58-8, 216-1
cafeteria /,kæfə'tɪrɪə/ 23-6
cake /keɪk/ 88-16, 229-25
 piece of... /pi:s əv/ 97-15
cake pan /keɪk pæn/ 95-30
calculator /'kælkjəleɪtər/ 155-11
calendar /'kæləndər/ 6-7
call /kɔ:l/ 40-16
 ...a realtor /ə 'ri:əltər/ 65-16
 ...the doctor /ðə 'dɔktər/ 137-20
call button /kɔ:l 'bʌtn/ 139-21
caller /'kɔlər/ 16-13
call in /kɔ:l ɪn/
 ...sick /sɪk/ 151-22
calling card /'kɔ:lɪŋ kɑ:d/ 16-3
calm /kɑ:m/ 38-5
camcorder /'kæm,kɔ:dər/ 226-4
camel /'kæməl/ 181-8
camera /'kæmərə/ 226-3
camisole /'kæməsoʊl/ 107-22
camp /kæmp/ 213-29
camper /'kæmpər/ 213-27
campfire /'kæmpfaɪər/ 213-28
camping /'kæmpɪŋ/ 212-213
camping stove /'kæmpɪŋ stəʊv/ 213-15
can /kæn/
 ...of soda /əv 'səʊdə/ 97-27
Canada /'kænədə/ 172-173
Canadian /kæn'eɪdɪən/ 44-1
candidate /'kændɪdeɪt/
 political... /pə'lɪtɪkəl/ 200-1
candle /'kændl/ 70-28
 light a... /laɪt ə/ 102-3
candles /'kændls/
 blow out... /'bləʊ aʊt/ 229-31
 light... /laɪt/ 229-30
candy bar /'kændɪ bɑ: / 99-25
cane /keɪn/ 142-17
canned goods /kænd gʊdʒ/ 99-12
canoe /kə'nu: / 213-8
can opener /kæn 'əʊpənər/ 94-16
cantaloupe /'kæntləʊp/ 83-12
canteen /kæn'teɪn/ 213-19
canvas /'kænvəs/ 203-12

- canyon /'kænyən/ 169-13
 Capitol (Building) /'kæpətəl ('bɪldɪŋ)/ 200-6
 capsule /'kæpsəl/ 142-2
 car /kɑr/
 compact... /kəm'pækt/ 118-30
 park the... /pɑrk ðə/ 123-25
 wash the... /wɑʃ ðə/ 79-16
 card /kɑrd/ 228-6
 remove your... /rə'mu:v yər/ 51-28
 car dealership /kɑr 'di:ləʃɪp/ 47-23
 cardigan /'kɑrdɪgən/
 ...sweater /'swetər/ 111-15
 cardinal /'kɑrdɪnəl/ 190-2
 cardiologist /,kɑrdi'ælədʒɪst/ 141-8
 cardiopulmonary resuscitation
 /,kɑrdiəu'pʌlmənəri ri,səsə'teɪʃən/ 139-24
 cards /kɑrð/ 224-1
 caring for clothes /'keərɪŋ fər kləʊz/ 114-115
 carnival /'kɑrnəvəl/ 216-19
 carousel /'kærə'sel/ 214-14
 carpenter /'kɑ:pəntər/ 147-26
 carpet /'kɑ:pɪt/ 74-3
 vacuum the... /'væk,yum ðə/ 79-7
 carrot /'kærət/ 84-19
 carrots /'kærəts/
 bunch of... /'bʌnʃ əv/ 97-29
 chop... /tʃɑp/ 93-23
 peel... /pi:l/ 93-22
 carry /'kæri/ 29-6
 ...a bag /ə bæɡ/ 165-18
 ...a tray /ə treɪ/ 102-4
 carry-on bag /'kæri-ən bæɡ/ 125-16
 stow your... /stəʊ yər/ 126-10
 carton /'kɑ:tɪn/
 ...of eggs /əv eɡz/ 97-23
 ...of orange juice /əv 'ɔrɪndʒ/ 97-10
 cartoon /kɑ:'tu:n/ 209-14
 cash /kæʃ/ 9-26, 51-6
 withdraw... /wɪð'drəʊ/ 51-26
 cashier /kæ'ʃɪr/ 9-15, 99-21, 147-24
 cashmere /'kæʒ,mɪr/ 113-9
 cash register /kæʃ 'reɒdʒɪstər/ 9-17, 99-16
 casserole (dish) /'kæsə,rəʊl (dɪʃ)/ 95-25
 cassette /kə'set/ 226-16
 cassette player /kə'set 'pleɪər/ 19-24
 cast /kæst/ 141-15
 castle /'kæsl/ 63-19
 casual /'kæʒuəl/
 ...clothes /kləʊz/ 111-24
 cat /kæt/ 152-17
 catalog /'kætəl,ɒɡ/ 52-14
 catcher /'kætʃər/ 220-8
 caterpillar /'kætə,pɪlər/ 182-20
 cauliflower /'kɒli,flaʊər/ 84-16
 caulking gun /'kɒkɪŋ ɡʌn/ 160-8
 cave /keɪv/ 169-14
 cavity /'kævəti/ 141-32
 C-clamp /si-klæmp/ 160-2
 CD /,si'di/ 226-13
 CD player /,si'di 'pleɪər/ 226-12
 personal... /'pɜ:snəl/ 226-10
 CD-ROM /,si,di-'rɒm/ 25-1
 CD-ROM drive /,si,di-'rɒm draɪv/ 25-28
 ceiling /'si:lɪŋ/ 72-17
 ceiling fan /'si:lɪŋ fæn/ 72-16
 celebrate /'selə,breɪt/ 31-20
 celebrations /,selə'breɪʃənz/ 228-229
 celery /'seləri/ 84-14
 cello /'ʃeləʊ/ 207-20
 cell phone /sel fəʊn/ 16-20
 turn off your... /tɜ:n əf yər/ 126-11
 Celsius /'selstəs/ 166-1
 centimeter /'sentə,mɪtər/ 163-2
 century /'senʃəri/ 4
 Certificate of Naturalization /sə'tɪfɪkət əv nætʃərələzeɪʃən/
 43-26
 chain /tʃeɪn/ 163-32
 chair /tʃeər/ 19-26, 70-22
 chairlift /'tʃeərlɪft/ 222-8
 chalet /ʃæ'leɪ/ 63-5
 chalk /tʃɔ:k/ 19-3
 change /tʃeɪndʒ/
 ...diapers /'daɪəpəz/ 29-8
 ...the sheets /ðə ʃi:ts/ 79-2
 ...the tire /'ðə taɪr/ 123-22
 changing table /'tʃeɪndʒɪŋ 'teɪbəl/ 57-26
 cheap /tʃi:p/ 14-16
 cheat /tʃi:t/
 ...on a test /ən ə test/ 18-31
 check /tʃek/ 21-24
 ...his blood pressure /hɪz bləd 'preʃər/ 137-23
 ...the monitors /ðə 'mɒnətər/ 126-6
 ...the oil /ðə ɔɪl/ 123-16
 ...your baggage /yər 'bæɡɪdʒ/ 126-3
 check /tʃek/ 51-13, 101-31
 ask for the... /æsk fər ðə/ 102-17
 pay the... /peɪ ðə/ 102-24
 personal... /'pɜ:snəl/ 9-25
 traveler's... /'trævələzr/ 9-24
 checkbook /'tʃek,bʊk/ 51-12
 checked /'tʃekt/ 113-18
 checker /'tʃekər/ 99-21
 checkers /'tʃekəz/ 224-15
 check in /'tʃek ɪn/ 126-1, 159-25
 check-in counter /'tʃek-ɪn 'kaʊntər/ 124-4
 checking account number /'tʃekɪŋ ə'kaʊnt 'nʌmbər/ 51-11
 check out /'tʃek aʊt/ 159-27
 ...books /bʊks/ 54-27
 checkout counter /'tʃek,aʊt 'kaʊntər/ 99-15
 checkout desk /'tʃek,aʊt desk/ 55-16
 checkup /'tʃek,ʌp/ 141-18
 cheddar cheese /'tʃedər tʃi:z/ 88-22
 cheek /tʃi:k/ 133-36
 cheerleader /'tʃɪr,lɪdər/ 220-26
 cheese /tʃi:z/
 cheddar... /'tʃedər/ 88-22
 grate... /ɡreɪt/ 92-11
 Swiss... /swɪs/ 88-24
 cheetah /'tʃi:tə/ 185-13
 chef /ʃef/ 101-1
 chemist /'keməst/ 194-4
 chemistry /'keməstri/ 194-3
 cherries /'tʃerɪz/ 83-21
 pound of... /paʊnd əv/ 97-19
 chess /tʃes/ 224-12
 chest /tʃest/ 133-46
 chicken /'tʃɪkən/ 87-31, 152-28
 baste... /beɪst/ 92-16
 roast... /rəʊst/ 92-15
 season... /'si:zən/ 92-14
 chicken breasts /'tʃɪkən breɪsts/ 87-29
 chicken pox /'tʃɪkən pɒks/ 135-6
 chicken teriyaki /'tʃɪkən teri'aki/ 91-21
 chickpeas /'tʃɪkpiz/ 84-10
 child /tʃaɪld/ 30
 childcare worker /'tʃaɪldkər 'wɜ:kər/ 57-17
 child car seat /tʃaɪld kɑr si:t/ 121-1
 children's program /'tʃɪldrənz 'prəʊ,ɡræm/ 209-19
 Chilean /tʃɪ'lɪən/ 44-8
 chimney /'tʃɪmni/ 69-1

- chimpanzee /ʃɪmpæn'zi/ 182-3
 chin /tʃɪn/ 133-38
 Chinese /tʃaɪ'niz/ 44-23
 chin-up /tʃɪn-ʌp/ 218-11
 chipmunk /'tʃɪp,mʌŋk/ 190-21
 chips /'tʃɪps/
 potato... /pə'teɪtəʊ/ 99-27
 chisel /'tʃɪzəl/ 160-14
 chocolates /'tʃɔːklɪts/ 228-5
 choke /tʃoʊk/ 136-7
 choose /tʃuz/ 126-20
 chop /tʃɒp/ 93-23
 chopsticks /'tʃɒp,stɪks/ 90-18
 Christmas /'krɪsməs/ 229-19
 Christmas tree /'krɪsməs tri/ 229-22
 chrysanthemums /kri'sænthəməmz/ 179-21
 church /tʃɜːtʃ/ 47-13
 cider /'saɪdər/
 gallon of... /'gælən ʌv/ 97-21
 cinnamon /sɪnəmon/
 sift... /sɪft/ 93-28
circle /'sɜːkəl/ 21-28
 circle /'sɜːkəl/ 193-16
 circuit breaker /'sɜːkɪt/ 77-13
 circular saw /'sɜːkyələr sɔː/ 161-31
 circulation desk /,sɜːkyə'ləɪʃən desk/ 55-16
 circumference /sə'r'kʌmfərəns/ 193-13
 circus /'sɜːkəs/ 216-15
 citizen /'sɪtəzən/ 200-4
 citizenship /'sɪtəzən,ʃɪp/ 200-201
 city /'sɪti/ 43-12, 63-20
 city hall /'sɪti hɔːl/ 47-17
 city park /'sɪti pɑːk/ 214-215
 city square /'sɪti skwɛr/ 58-59
claim /kleɪm/
 ...your bags /yər bægz/ 126-24
 clams /klæmz/ 87-16
clap /klæp/ 204-26
 clarinet /,klærə'net/ 207-14
 classical /'klæsɪkəl/ 209-28
 classroom /'klæs,rʌm/ 18-19, 23-20
 claw /kloː/ 187-22
 clay /kleɪ/ 203-21
 clean /kliːn/ 14-6
clean /kliːn/ 79-10
 cleaner /'kliːnər/ 48-17
 vacuum... /'væk,yʊm/ 80-5
 cleaning supplies /'kliːnɪŋ/ 80-81
 cleanser /'klenzər/ 80-19
clear /klɪr/ 102-25
 clerk /clɜːk/
 postal... /'pəʊstəl/ 52-20
click /klɪk/ 24-33
 cliff /klɪf/ 169-27
climb /klaɪm/ 165-14
 clock /klɒk/ 19-13
 clock times /klɒk taɪmz/ 5
 clog /klog/ 109-20
 clogged /klogd/ 77-2
close /klaʊz/ 20-9
 closed /klaʊzd/ 15-38
 closet /'klɒzɪt/ 74-1
 close to /klaʊz tə/ 13-15
 cloth diaper /klaʊð 'daɪəpər/ 57-29
 clothes /klaʊðz/ 104-105
 casual... /'kæʒuəl/ 111-24
 dress... /dres/ 111-25
 fold the... /fəʊld ðə/ 79-5
 formal... /'fɔːməl/ 111-25
 informal... /ɪn'fɔːməl/ 111-24
 clothesline /'klaʊz,ləɪn/ 107-1
 clothespin /'klaʊz,pɪn/ 107-2
 CLOTHING /'klaʊðɪŋ/ 104-117
 clothing store /'klaʊðɪŋ stɔːr/ 48-2
 cloud /klaʊd/ 166-12
 cloudy /'klaʊdi/ 167-26
 club /klʌb/ 224-9
 golf... /gɒlf/ 220-13
 clutch /klʌtʃ/ 121-25
 coach /kəʊtʃ/ 23-1
 coach (class) /kəʊtʃ (klæs)/ 125-23
 coal /kəʊl/ 171-26
 coat /kəʊt/ 104-30
 cockroaches /'kɒk,rəʊtʃez/ 76-27
 coconut /'kəʊkə,nʌt/ 83-13
 cod /kɒd/ 87-22, 189-16
 coffee /'kɒfi/ 90-11
 cup of... /kʌp ʌv/ 97-13
 pot of... /pɒt ʌv/ 97-12
 coffee break /'kɒfi breɪk/
 take a... /teɪk ə/ 34-12
 coffeemaker /'kɒfimeɪkər/ 70-10
 coffee shop /'kɒfi ʃɒp/ 48-20
 coffee table /'kɒfi 'teɪbəl/ 72-12
 coin /kɔɪn/ 16-4
 coin return /kɔɪn rɪ'tɜːn/ 16-7
 coins /kɔɪnz/ 8
 colander /'kɒləndər/ 95-27
 cold (illness) /kəʊld/ 135-5
 cold (temperature) /kəʊld/ 15-30, 166-6
 cold cuts /kəʊld kʌts/ 88-21
 collar /'kɒlər/ 117-12
collect /kə'lekt/ 20-3
 college /'kɒlɪdʒ/ 47-9
 go to... /gəʊ tu/ 31-6
 college degree /'kɒlɪdʒ dɪ'grɪ/ 43-27
 Colombian /kə'lɒmbiən/ 44-5
 colon /'kəʊlən/ 196-17
 colors /'kɒlərz/ 10-11
comb /kəʊm/ 34-5
 comb /kəʊm/ 144-8
 comedy /'kɒmədi/ 208-2
 comet /'kɒmɪt/ 176-19
comfort /'kɒmfɜːt/ 29-12, 40-13
 comfortable /'kɒmfətəbəl/ 39-24
 comforter /'kɒmfətər/ 74-16
 comma /'kɒmə/ 196-11
 COMMUNITY /kə'mjuːnəti/ 46-61
 compact car /'kɒm,pækt kɑːr/ 118-30
 compact disc /'kɒm,pækt dɪsk/ 226-13
 compass /'kɒmpəs/ 213-1
compliment /'kɒmplɪmənt/ 40-10, 102-13
composes /kəm'pəʊzəz/ 198-10
 computer /kəm'pyʊtər/ 155-8
 desktop... /'desk,tɒp/ 25-17
 handheld... /'hænd,held/ 25-16
 laptop... /'læp,tɒp/ 25-23
 notebook... /'nəʊtbʊk/ 25-23
 use a... /yuz ə/ 151-21
 computerized catalog /kəm'pyʊtə,rəɪzd 'kætɪl,ɒg/ 55-6
 computer program /kəm'pyʊtər 'prəʊ,græm/ 25-25
 computers /kəm'pyʊtərz/ 24-25
 computer technician /kəm'pyʊtər tek'nɪʃən/ 146-10
 concert /'kɒnsərt/
 rock... /rɒk/ 205-10
 concierge /kə'syɛrʒ/ 159-13
 concrete /kən'kriːt/
 pour... /pɔːr/ 165-7
 conditioner /kən'dɪʃənər/ 144-3
 condo /'kændəʊ/ 63-10

condominium /ˌkɒndəˈmɪniəm/ 63–10
 conductor /kənˈdʌktər/ 128–13, 204–7
 cone /kəʊn/ 193–24
 confused /kənˈfjuːzd/ 39–18
congratulate /kənˈgræʃəˌleɪt/ 40–24
 Congress /ˈkɒŋɡrɪs/ 201
 congressman /ˈkɒŋɡrɪsmən/ 200–9
 congresswoman /ˈkɒŋɡrɪswʊmən/ 200–9
 constellation /ˌkɒnstəˈleɪʃən/ 176–2
 construction worker /kənˈstrʌkʃən ˈwɜːkər/ 146–6
 contact (lens) /ˈkɒn.tækt (leɪnz)/ 141–22
 container /kənˈteɪnər/ 97–25
 containers /kənˈteɪnərz/ 96–97
 continents /ˈkɒntɪnənts/ 174
 conversation /ˌkɒnvərˈseɪʃən/
 have a... /hæv ə/ 17–28, 40–6
 convertible /kənˈvɜːrtəbəl/ 118–31
 conveyor belt /kənˈveɪər belt/ 156–6
cook /kʊk/ 79–22, 93–24, 150–1
 cook /kʊk/ 146–4
 cookbook /ˈkʊk.bʊk/ 55–22
 cookie sheet /ˈkʊki ʃiːt/ 95–21
 grease a... /ɡreɪs ə/ 93–26
 cooking /ˈkʊkɪŋ/ 92–93
 do the... /du ðə/ 79–22
 cooking equipment /ˈkʊkɪŋ ɪˈkwɪpmənt/ 94–95
 cool /kuːl/ 166–5
 cooler /ˈkuːlər/ 211–18
 cop /kɒp/
 traffic... /ˈtræfɪk/ 58–6
 copier /ˈkəpiər/ 155–4
 copies /ˈkɒpiz/
 make... /meɪk/ 151–20
copy /ˈkɒpi/ 20–4
 copy /ˈkɒpi/ 155–5
 copy machine /ˈkɒpi məˈʃɪn/ 155–4
 copy shop /ˈkɒpi ʃɒp/ 48–15
 coral /ˈkɒrəl/ 10–3
 coral reef /ˈkɒrəl rif/ 189–26
 cord /kɔːrd/ 16–15
 extension... /ɪkˈstɛnʃən/ 160–20
 cordless phone /ˈkɔːdlɪs fəʊn/ 16–19
 corduroy /ˈkɔːdʊrɔɪ/ 113–2
 corn /kɔːrn/ 84–24
 corner /ˈkɔːnər/ 47–25
 cornrows /ˈkɔːnrəʊz/ 33–25
correct /kəˈrɛkt/ 21–25
 correction fluid /kəˈrɛkʃən ˈflɪd/ 155–28
 costume /ˈkɒstəm/ 204–5, 228–14
 cottage /ˈkɒtɪdʒ/ 63–3
 cotton /ˈkɒtn/ 113–1
 couch /kaʊtʃ/ 72–8
 cough /kɒf/ 137–16
 cough /kɒf/ 135–3
 cough drops /kɒf drɒps/ 142–10
 cough syrup /kɒf ˈsɪrəp/ 142–7
 counselor /ˈkaʊnslə/ɹ/
 guidance... /ˈɡaɪdnz/ 23–17
 counter(top) /ˈkaʊntər(tɒp)/ 70–5
 country /ˈkʌntri/ 63–23
 country and western /ˈkʌntri ənd ˈwestən/ 209–29
 courthouse /ˈkɔːt,haʊs/ 47–19
 courtroom /ˈkɔːt,rʊm/ 61–25
 courtyard /ˈkɔːt,yɑːrd/ 67–17
 cousin /ˈkʌzən/ 27–11
 cow /kaʊ/ 152–26
 coyote /kaiˈoʊti/ 181–4
 CPR /si pi ar/ 139–24
 crab /kræb/ 87–18, 189–24
 cracked /krækt/ 77–4

crate /kreɪt/ 97–30
 crater /ˈkreɪtər/ 169–10
crawl /krɔːl/ 29–22, 37–21
 crayons /ˈkreɪ,ɒnz/ 224–18
 cream /kriːm/ 10–21, 88–14
 creamer /ˈkriːmər/ 101–8
 credit card /ˈkredɪt kɑːrd/ 9–28
 crescent moon /kresənt muːn/ 177–30
 crew neck /kruː nek/
 ...sweater /ˈswetər/ 111–14
 crib /kriːb/ 57–3
 cricket /ˈkriːkɪt/ 181–22
 crime /kraɪm/ 60–61
 criminal /ˈkrɪmɪnəl/ 61–18
crochet /krouˈʃeɪ/ 224–26
 crochet hook /krouˈʃeɪ hʊk/ 224–22
 crocodile /ˈkrɒkəˌdaɪl/ 182–19
 crop /krɒp/ 152–11
cross /krɒs/ 37–10
 cross-country skiing /krɒs-ˈkʌntri ˈskiɪŋ/ 222–11
cross out /krɒs aʊt/ 21–23
 crosswalk /ˈkrɒs,wɔːk/ 58–18
 crutch /ˈkrʌtʃ/ 141–14
cry /kraɪ/ 29–23
 cub /kʌb/
 bear... /ber/ 187–9
 cubby /ˈkʌbi/ 57–12
 cube /kyʊb/ 193–22
 cucumber /ˈkyʊ,kʌmbər/ 84–25
 cuff /kʌf/ 117–17
 cup /kʌp/ 96, 97–2, 101–18
 ...of coffee /ʌv ˈkɒfi/ 97–13
 curb /kɜːrb/ 58–15
 curlers /ˈkɜːləz/ 144–9
 curling iron /ˈkɜːlɪŋ ˈaɪrən/ 144–5
 curly hair /ˈkɜːli heə/ 33–18
 cursor /ˈkɜːsər/ 25–6
 curtain rod /ˈkɜːtn rɒd/ 72–15
 curtain /ˈkɜːtn/ 72–20
 curved line /kɜːvd laɪn/ 193–8
 cushion /ˈkʊʃən/ 72–2
 custodian /kʌˈstəʊdiən/ 146–11
 customer /ˈkʌstəmər/ 51–7, 101–7
 customs /ˈkʌstəmz/ 125–17
 customs (declaration) form /ˈkʌstəmz (ˌdekləˈreɪʃən) fɔːm/
 125–18
cut /kʌt/
 ...a pipe /ə paɪp/ 165–21
 ...yourself /yerˈself/ 136–8
 cut /kʌt/ 135–23
cut off /kʌt ɔːf/ 114–7
 cutting board /ˈkʌtɪŋ bɔːrd/ 94–1
 cyclist /ˈsaɪklɪst/ 214–25
 cylinder /ˈsɪləndər/ 193–25
 graduated... /ˈɡrædʒuˌeɪtɪd/ 194–20
 cymbals /ˈsɪmbəlz/ 207–2
 daffodils /ˈdæfəˌdɪls/ 179–22
 daily activities /ˈdeɪli ækˈtɪvətɪz/ 34–35
 dairy products /ˈdeəri ˈprɒdʌkts/ 99–3
 daisies /ˈdeɪzɪz/ 179–31
dance /dæns/ 40–22
 dancer /dænsər/ 204–3
darken /ˈdɑːkən/ 21–29
 dartboard /ˈdɑːt bɔːrd/ 218–29
 darts /ˈdɑːts/ 218–30
 dashboard /ˈdæʃ,bɔːrd/ 121–16
date /deɪt/ 31–9
 date /deɪt/ 6–1
 date book /deɪt bʊk/ 155–14
 date of birth /deɪt ʌv bɜːθ/ 43–6

dates /deɪts/ 83-24
 daughter /'dɔ:tər/ 27-22
 dawn /dɔ:n/ 5
 day /deɪ/ 4
 daycare center /'deɪ,kər 'sentər/ 56-57
 days of the week /deɪz əv ðə wɪk/ 6
 dead /ded/ 14-12
 dead-bolt (lock) /'ded-,bəʊlt (lɒk)/ 67-28
 deaf /def/ 135-21
 debit card /'debit kɑ:d/ 9-27
 decade /'dekeɪd/ 4
 December /dɪ'sembər/ 7-27
 decision /dɪ'sɪʒən/
 make a... /meɪk ə/ 65-18, 151-26
 deck /dek/ 69-5
decorate /'dekoʊreɪt/ 64-13
 deer /dɪr/ 190-9
defends /dɪ'fendz/ 198-6
 dell counter /'delɪ 'kaʊntər/ 99-6
deliver /də'lɪvər/ 150-7
 delivery person /də'lɪvəri 'pɜ:nsn/ 146-9
demonstrate /'demənstreɪt/ 201-18
 denim /'denəm/ 113-6
 dental floss /'dentl flɒs/ 144-13
 dental hygienist /'dentl haɪ'ɟɪnɪst/ 141-25
 dentist /'dentɪst/ 141-26, 146-2
 deodorant /di'ɔ:ðərənt/ 144-20
 department store /dɪ'pɑ:tmənt stɔ:r/ 48-25
 deposit /dɪ'pɒsɪt/ 51-16
 make a... /meɪk ə/ 51-27
 depth /depθ/ 193
 describing clothes /dɪ'skraɪbɪŋ kləʊz/ 110-111
 desert /'dezərt/ 169-11, 180-181
design /dɪ'zain/ 151-19
 designer /dɪ'zainər/ 156-1
 desk /desk/ 19-21, 155-7
 desk clerk /desk klɜ:k/ 159-11
 desktop (computer) /'desktɒp (kəm'pyutər)/ 25-17
 dessert /dɪ'zɜ:t/ 101-28
 share a... /ʃer ə/ 102-19
 destination /,destə'neɪʃən/
 arrive at the... /ə'raɪv ət ðə/ 123-24
 detergent /dɪ'tɜ:dʒənt/
 laundry... /'ləʊndri/ 116-4
dial /'daɪəl/ 17-25
 diameter /daɪ'æmɪtər/ 193-15
 diamond /'daɪəmənd/ 224-8
 diaper /'daɪəpər/
 cloth... /klɒθ/ 57-29
 disposable... /dɪ'spəʊzəbəl/ 57-27
 diaper pail /'daɪəpər,peɪl/ 57-21
 diaper pin /'daɪəpər,pɪn/ 57-30
 diapers /'daɪəpərz/
 change... /ʃeɪndʒ/ 29-8
dice /daɪs/ 92-2
 dice /daɪs/ 224-17
 dictionary /'dɪkʃənəri/ 55-9
 look up a word in the... /lʊk ʌp ə wɜ:rd ɪn ðə/ 20-8
dile /daɪ/ 31-24
 difficult /'dɪfɪ,kəlt/ 14-8
dig /dɪg/ 165-22
 dime /daɪm/ 8-3
 dimple /'dɪmpəl/ 33-9
 diner /'daɪnər/ 101-7
 dining area /'daɪnɪŋ 'erɪə/ 70-71
 dinner /'dɪnər/
 eat... /ɪt/ 34-19
 have... /hæv/ 34-19
 make... /meɪk/ 34-18
 directions /dɪ'rekʃənz/

 ask for... /æsk fər/ 123-4
 directory assistance /dɪ'rektəri ə'sɪstəns/ 16-6
 dirty /'dɜ:ti/ 14-5
 disabilities /,dɪsə'bɪlətɪz/ 134-135
disagree /,dɪsə'grɪ/ 40-12
discipline /'dɪsə,plɪn/ 29-13
discovers /dɪ'skʌvəz/ 198-9
discuss /dɪ'skʌs/
 ...your ideas /jər aɪ'dɪəz/ 20-11
 dishes /dɪʃəz/ 70-3
 do the... /du ðə/ 79-21
 dry the... /draɪ ðə/ 79-23
 put away the... /put ə'weɪ ðə/ 79-24
 wash the... /wɒʃ ðə/ 79-21
 dish rack /dɪʃ ræk/ 70-16
 dish soap /dɪʃ səʊp/ 80-13
 dish towel /dɪʃ təʊəl/ 70-18
 dishwasher /'dɪʃ,wɒʃər/ 70-14, 101-2
 dishwasher detergent /'dɪʃ,wɒʃər dɪ'tɜ:dʒənt/ 80-12
 dishwashing liquid /'dɪʃ,wɒʃɪŋ 'lɪkwɪd/ 80-13
 disk /dɪsk/ 25-2
 disposable diaper /dɪ'spəʊzəbəl 'daɪəpər/ 57-27
dive /daɪv/ 210-31
 diver /'daɪvər/ 189-13, 218-33
 divided by /dɪ'vaɪdɪd baɪ/ 193-6
 diving board /'daɪvɪŋ bɔ:rd/ 218-32
 diving mask /'daɪvɪŋ mæsk/ 211-26
 division /dɪ'vɪʒən/ 193-29
 divorced /dɪ'vɔ:st/ 26-28
 dizzy /'dɪzi/ 135-20
do /du/
 ...homework /'həʊm,wɜ:k/ 34-17
 ...housework /'haʊs,wɜ:k/ 34-21
 ...the cooking /ðə 'kʊkɪŋ/ 79-22
 ...the dishes /ðə dɪʃəz/ 79-21
 ...the laundry /ðə 'ləʊndri/ 79-3
 doctor /'dɒktər/ 139-16, 146-12
 call the... /kɔ:l ðə/ 137-20
 documentary /,dɒkjə'mentəri/ 208-10
 documents /'dɒkjəmənts/ 42-43
 dog /dɒg/ 152-16
 doggie bag /'dɒgi bæɡ/
 offer a... /'ɔ:fər ə/ 102-20
 doll /dɔ:l/ 224-19
 dolly /'dɒli/ 157-19
 dolphin /'dɒlfɪn/ 189-2
 dominoes /'dɒmə,nəʊz/ 224-14
 donkey /'dɒŋki/ 152-24
 do not enter /du nɒt 'entər/ 118-5
 do not pass /du nɒt pæs/ 118-4
 door /dɔ:r/ 69-12
 doorbell /'dɔ:r,bel/ 69-13
 door chain /dɔ:r ʃeɪn/ 67-27
 doorknob /'dɔ:r,nɒb/ 67-29
 doorman /'dɔ:r,mæn/ 67-25
 dorm /dɔ:rm/ 63-18
 dormitory /'dɔ:rmɪ,tɔ:ri/ 63-18
 double room /'dʌbəl rum/ 159-17
 doughnut /'dɒʊ,nʌt/ 90-15
 down /daʊn/ 130-11
 downhill skiing /'daʊn'hɪl 'skiɪŋ/ 222-12
 down payment /'daʊn 'peɪmənt/
 make a... /meɪk ə/ 65-23
 draft /dræft/
 type your... /taɪp jər/ 196-25
 write a... /raɪt ə/ 196-22
 dragonfly /'dræɡən,flaɪ/ 190-23
 drain /dreɪn/ 75-20
 drama /'dræmə/ 208-4
 drama club /'dræmə klʌb/ 23-23

draw /drə/ 203–24
 ...blood /blʌd/ 137–24
drawer /drɔːr/ 74–5
dress /dres/ 29–11
dress /dres/ 104–1
 ...clothes /kloʊz/ 111–25
dresser /ˈdresər/ 74–6
dressing /ˈdresɪŋ/
 salad... /ˈsæləd/ 88–19
dressing room /ˈdresɪŋ rʊm/
 go into a... /ˈɡoʊ ˈɪntu ə/ 114–3
drill /drɪl/ 165–4
drill /drɪl/ 141–31, 161–28
drill bit /drɪl bɪt/ 161–29
drink /drɪŋk/ 102–12, 137–28
drink /drɪŋk/
 spill a... /spɪl ə/ 102–9
drips /drɪps/ 77–5
drive /draɪv/ 123–3, 151–25
driver's license /ˈdraɪvərz ˈlaɪsəns/ 43–18
drive-up window /ˈdraɪv-ʌp ˈwɪndəʊ/ 51–21
driveway /ˈdraɪvweɪ/ 69–18
drop down menu /drɒp daʊn ˈmenju/ 25–8
drop off /drɒp ɒf/ 29–18
dropper /ˈdrɒpər/ 194–21
drought /draʊt/ 171–3
drown /draʊn/ 136–9
drug dealing /drʌg ˈdɪlɪŋ/ 61–5
drugstore /ˈdrʌgstɔːr/ 48–26
drummer /ˈdrʌmə/ 205–12
drums /drʌmz/ 207–1
drumsticks /ˈdrʌmstɪks/ 87–33
drunk driving /drʌŋk ˈdraɪvɪŋ/ 61–6
dry /draɪ/ 114–19
 ...the dishes /ðə ˈdɪʃəz/ 79–23
dry clean /draɪ kliːn/ 115–20
dry cleaner /draɪ ˈkliːnər/ 48–17
dry clothes /draɪ kloʊz/ 116–9
dryer /ˈdraɪər/ 116–6
drying rack /ˈdraɪɪŋ ræk/ 70–16
drywall /ˈdraɪwɔːl/ 163–4
 put up... /put ʌp/ 165–1
duck /dʌk/ 87–32, 190–14
duct tape /dʌkt teɪp/ 163–31
dumpster /ˈdʌmpstɔːr/ 67–2
dump truck /dʌmp trʌk/ 118–21
duplex /ˈdʌpleks/ 63–6
dusk /ˈdʌsk/ 5
dust /dʌst/ 79–8
dust cloth /dʌst klɒθ/ 80–10
dust mop /dʌst mɒp/ 80–27
dustpan /ˈdʌstpæn/ 80–2
DVD /diːviːdi/ 226–25
DVD player /diːviːdi ˈpleɪər/ 226–24
eagle /ˈiːɡəl/ 190–5
ear /ɪr/ 133–35
earache /ˈɪr,eɪk/ 135–1
earmuffs /ˈɪr,mʌfs/ 109–28
 safety... /ˈseɪfti/ 157–29
earplugs /ˈɪr,plʌgz/ 157–24
earrings /ˈɪrɪŋz/ 109–9
Earth /ɜːθ/ 176–26
EARTH AND SPACE /ɜːθ ənd speɪs/ 166–177
earthquake /ˈɜːθ,kweɪk/ 171–5
Earth's atmosphere /ɜːθs ˈætəmɒs,fɪr/ 176–15
Earth's surface /ɜːθs ˈsɜːfəs/ 168–169
easel /ˈiːzəl/ 203–11
east /iːst/ 130–20
easy /ˈiːzi/ 14–7
easy chair /ˈiːzi tʃeə/ 72–3

eat /iːt/ 102–15
 ...breakfast /ˈbreɪkfəst/ 34–9
 ...dinner /ˈdɪnər/ 34–19
 ...lunch /ˈlʌnʃ/ 34–13
eclipse /ɪˈkliːps/ 176–5
economy (class) /ɪˈkɒnəmi (klæs)/ 125–23
edit /ˈedɪt/ 196–24
editor /ˈedɪtər/ 146–16
eel /iːl/ 189–18
eggplant /ˈeg,plænt/ 84–12
egg roll /eg rɔːl/ 91–22
eggs /egz/ 88–25
 carton of... /ˈkɑːtn ʌv/ 97–23
 fry... /fraɪ/ 92–8
 scramble... /ˈskræmbəl/ 92–7
Egyptian /ˈɛdʒɪpʃən/ 44–18
eight /eɪt/ 2
eighteen /eɪˈtiːn/ 2
eighteenth /eɪˈtiːnθ/ 3
eighth /eɪtθ/ 3
eighty /ˈeɪti/ 2
eject /ɪˈdʒekt/ 227–31
EKG /ˈiːkeɪˈdʒi/ 141–9
elastic bandage /ɪˈlæstɪk ˈbændɪdʒ/ 142–19
elbow /ˈelboʊ/ 133–9
electrical /ɪˈlektrekəl/ 161
electrical hazard /ɪˈlektrekəl ˈhæzərd/ 156–31
electrical tape /ɪˈlektrekəl teɪp/ 160–19
electrician /ɪˈlekˈtriʃən/ 77–14, 147–27
electric keyboard /ɪˈlektɪk ˈkɪbɔːrd/ 207–25
electric pencil sharpener /ɪˈlektɪk ˈpensəl ʃɑːpənər/ 155–21
electric razor /ɪˈlektɪk ˈreɪzər/ 144–19
electric shaver /ɪˈlektɪk ˈʃeɪvər/ 144–19
electric shock /ɪˈlektɪk ʃɒk/
 get an... /get ən/ 136–14
electrocardiogram /ɪˈlektɪkɑːrdiəˌɡræm/ 141–9
electronics store /ɪˈlektˈrɒnɪks stɔːr/ 48–1
elects /ɪˈlekt/ 198–20
element /ˈeləmənt/ 194–16
elephant /ˈeləfənt/ 185–10
elevator /ˈeləˌveɪtər/ 67–23
eleven /ɪˈlevən/ 2
eleventh /ɪˈlevənθ/ 3
elm (tree) /elm (tri)/ 179–6
e-mail (message) /iːˌmeɪl (ˈmesɪdʒ)/ 25–22
e-mail address /iːˌmeɪl əˈdres/ 43–10
embarrassed /emˈbærəsd/ 38–7
embroider /emˈbrɔɪdə/ 224–27
embroidered /emˈbrɔɪdərd/ 113–21
embroidery thread /emˈbrɔɪdəri θreɪd/ 224–23
emergency assistance /ɪˈmɜːdʒənsi əˈsɪstəns/ 16–5
emergency brake /ɪˈmɜːdʒənsi breɪk/ 121–28
emergency exit /ɪˈmɜːdʒənsi ˈegzɪt/ 125–25
emergency room /ɪˈmɜːdʒənsi rʊm/ 139–25
empty /ˈempti/ 79–13
empty /ˈempti/ 14–20
EMT /i ɛm ti/ 139–26
encourage /enˈkʌrɪdʒ/ 29–15
encyclopedia /enˌsaɪkləˈpiːdiə/ 55–10
ends /endz/ 198–14
end table /end ˈteɪbəl/ 72–4
energy /ˈenərʒi/ 170–171
 geothermal... /ˌdʒiəʊˈθɜːrməl/ 171–25
 nuclear... /ˈnuːkliər/ 171–28
 solar... /ˈsoʊlə/ 171–27
engine /ˈendʒɪn/ 121–32
engineer /ˌendʒəˈnɪr/ 146–22
enter /ˈentər/ 37–3
 ...your password /jər ˈpæs,wɜːrd/ 24–31
 ...your PIN /jər pɪn/ 51–25

- envelope /'envə,ləʊp/ 52-8
equals /'iːkwəlz/ 193-3
Equator /'iːkweɪtər/ 174-3
erase /'ɪreɪs/ 20-17
eraser /'ɪreɪsər/ 19-22
 blackboard... /'blæk,bɔːrd/ 19-4
escalator /'eskəleɪtər/ 159-10
essay /'eseɪ/ 196-5
 edit your... /'edɪt jɔːr/ 196-24
Europe /'jʊərəp/ 174-10
evening /'iːvniŋ/ 5
exam /ɪg'zæm/ 19-29
examine /ɪg'zæməɪn/ 150-2
 ...the patient /ðə peɪʃənt/ 137-22
exchange /ɪks'tʃeɪndʒ/ 20-5
excited /ɪk'saɪtɪd/ 39-20
exclamation mark /ɪksklə'meɪʃən mɑːk/ 196-13
exclamation point /ɪksklə'meɪʃən pɔɪnt/ 196-13
Executive branch /ɪk'zɛkyətɪv bræŋtʃ/ 201
exercise /'eksəsaɪz/ 34-16
expensive /ɪk'spensɪv/ 14-15
explores /ɪk'splɔːr/ 198-8
explosive materials /ɪk'splɔʊsɪv mə'tɪrɪəlz/ 156-32
extension cord /ɪk'stɛnʃən kɔːrd/ 160-20
exterminator /ɪk'stɜːmɪneɪtər/ 77-18
eye /aɪ/ 133-39
eyebrow /'aɪ,braʊ/ 133-34
eye chart /aɪ tʃɑːrt/ 141-21
eyedrops /'aɪ,drɒps/ 142-13
eyeglasses /'aɪglæsɪz/ 141-24
eye hook /aɪ hʊk/ 163-19
eyelashes /'aɪ,læʃəs/ 133-40
eyeliner /'aɪ,ləɪnər/ 144-31
eye shadow /aɪ 'ʃædəʊ/ 144-29
fabrics /'fæbrɪks/ 112-113
fabric softener /'fæbrɪk 'sɒfənər/ 116-3
face /feɪs/ 32-33, 133-31
face powder /'feɪs 'paʊdər/ 144-26
factory /'fæktəri/ 47-1, 156-157
Fahrenheit /'færən,haɪt/ 166-2
fail /feɪl/
 ...a test /ə tɛst/ 18-32
falcon /'fælkən/ 187-19
fall /fɔːl/ 7-14
fall /fɔːl/ 37-7, 136-15
fall in love /fɔːl ɪn lʌv/ 31-10
falls /fɔːlz/ 198-19
FAMILY /'fæməli/ 26-31
family /'fæməli/ 26-27
 raise a... /reɪz ə/ 31-16
family name /'fæməli neɪm/ 43-2
famine /'fæɪn/ 171-4
fan /fæn/ 220-20
 ceiling... /'siːlɪŋ/ 72-16
fantasy /'fæntəsi/ 208-8
fare /fer/ 128-3
fare card /fer kɑːrd/ 128-21
far from /fɑː frəm/ 13-2
farm /fɑːm/ 152-153
farmer /'fɑːmə/ 152-14
farmhand /'fɑːmhænd/ 152-6
farmhouse /'fɑːmhaʊs/ 63-8, 152-15
farmworker /'fɑːm,wɜːkər/ 152-6
fast /fæst/ 15-34
fasten /'fæsn/ 126-12
fast food restaurant /fæst fuːd 'restərɒnt/ 48-24
fast forward /fæst 'fɔːrwɜːd/ 227-27
fat /fæt/ 15-25
father /'fɑːðər/ 27-6
father-in-law /'fɑːðər-m-,lɔː/ 27-10
faucet /'fəʊsɪt/ 75-27
 ...drips /'dɪrps/ 77-5
fax machine /fæks mə'ʃɪn/ 155-3
feather duster /'feðər 'dʌstər/ 80-1
feather /'feðər/ 187-23
February /'febyʊəri/ 7-17
feed /fiːd/ 29-5, 153-33
feedback /'fiːdbæk/
 get... /get/ 196-23
feel /fiːl/
 ...better /'betər/ 137-29
feelings /'fiːlɪŋz/ 38-39
feet /fiːt/ 162
female /'fiːmeɪl/ 42
fence /fens/ 69-24
fender /'fendər/ 121-31
fern /'fɜːn/ 182-16
Ferris wheel /'ferɪs wiːl/ 214-15
ferry /'feri/ 128-17
fever /'fevər/ 135-15
fiction section /'fɪkʃən 'sekʃən/ 55-7
field /fiːld/ 152-9
fifteen /'fɪf'tiːn/ 2
fifteenth /'fɪf'tiːnθ/ 3
fifth /fɪfθ/ 3
fifty /'fɪfti/ 2
fifty cents /'fɪfti sents/ 8-5
fifty-dollar bill /'fɪfti-'dɒlə bɪl/ 8-10
fifty dollars /'fɪfti 'dɒləz/ 8-10
figs /fɪgz/ 83-22
file /faɪl/ 151-24
file /faɪl/ 25-7, 160-7
file cabinet /faɪl 'kæbɪnɪt/ 155-18
file folder /faɪl 'fəʊldər/ 155-20
filet of sole /'fiːlət əv sɔːl/ 87-21
Fillipino /fɪlə'piːnoʊ/ 44-28
fill in /'fɪl ɪn/ 21-26
filling /'fɪlɪŋ/ 141-27
film /fɪlm/
 roll of... /rɔːl əv/ 226-1
films /fɪlmz/ 208-209
fin /fɪn/ 189-5
find /faɪnd/ 126-9
finding a place to live /'faɪndɪŋ ə pleɪs tə liv/ 64-65
fine arts /faɪn ɑːrts/ 202-203
finger /'fɪŋgər/ 133-5
fingernail /'fɪŋgər,neɪl/ 133-23
fins /fɪnz/ 211-27
fire /faɪə/ 72-30
 forest... /'fɔːrɪst/ 171-1
firecracker /'faɪə,krækər/ 228-2
fire engine /faɪə 'ɛndʒɪn/ 118-28
fire escape /faɪə ɪ'skeɪp/ 67-19
fire extinguisher /faɪə ɪk'stɪŋgwɪʃər/ 157-17
firefighter /'faɪə,faɪtər/ 147-28
fire hydrant /faɪə 'haɪdrənt/ 58-11
fireplace /'faɪə,pleɪs/ 72-27
fire screen /faɪə skriːn/ 72-28
fire station /faɪə 'steɪʃən/ 47-16
fireworks /'faɪə,wɜːks/ 228-8
first /fɜːst/ 3
first-aid kit /fɜːst-əɪd kɪt/ 143-23
first class /fɜːst klæs/ 125-22
first name /fɜːst neɪm/ 43-3
fish /fɪʃ/ 213-30
fish /fɪʃ/ 87
fish and chips /fɪʃ ənd tʃɪps/ 90-6
fisherman /'fɪʃərɪmən/ 213-6
fishing pole /'fɪʃɪŋ pəʊl/ 213-5
fitness center /'fɪtnɪs 'sɛntər/ 159-19

fittings /'fɪtɪŋz/ 160-24
 five /faɪv/ 2
 five after six /faɪv 'æftər sɪks/ 5
 five cents /faɪv sents/ 8-2
 five-dollar bill /faɪv-'dɒlə bɪl/ 8-7
 five dollars /faɪv 'dɒləz/ 8-7
 five of seven /faɪv ɒv 'sevən/ 5
 five past six /faɪv pæst sɪks/ 5
 five to seven /faɪv tə 'sevən/ 5
fix /fɪks/ 150-15
 flag /flæɡ/ 19-8
 flamingo /flə'mɪŋɡoʊ/ 182-15
 flammable materials /'flæməbəl mə'tɪəriəl/ 156-33
 flared /flɛəd/
 ...jeans /dʒiːnz/ 111-10
 flashlight /'flæʃlaɪt/ 163-8
 flask /flæsk/ 194-24
 flat tire /flæt taɪr/
 have a... /hæv ə/ 123-21
 flea market /fli 'mɑːkɪt/ 48-30
 flight attendant /flaɪt ə'tendənt/ 125-26
 flip flops /'flɪp,flɒps/ 107-10
 flipper /'flɪpər/ 187-18
float /fləʊt/ 210-33
 flood /flʌd/ 171-6
 flooded /'flʌdəd/ 77-9
 floor /flɔːr/ 72-14
 mop the... /mɒp ðə/ 79-12
 sweep the... /swɪp ðə/ 79-4
 floral /'flɔːrəl/ 113-16
 florist /'flɔːrɪst/ 146-14
 flower /'flaʊər/ 179-14
 flowers /'flaʊəz/ 228-12
 bouquet of... /bəʊ'keɪ ɒv/ 97-6
 flower stand /'flaʊər stænd/ 48-19
 flu /flu/ 135-14
 fluids /'fljuːdz/
 drink... /drɪŋk/ 137-28
 flute /flut/ 207-12
fly /flaɪ/ 37-1, 198-13
 fly /flaɪ/ 181-20
 flyswatter /'flaɪ,swatər/ 80-22
 fog /fɒɡ/ 166-16
 foggy /'fɒɡi/ 167-29
fold /fəʊld/ 92-12
 ...the clothes /ðə kləʊz/ 79-5
 folder /'fəʊldər/ 25-5, 155-20
follow /'fɒləʊ/ 37-17
FOOD /fud/ 82-103
 food processor /fud 'prɒseseɪər/ 94-8
 food to go /'fud tə ɡoʊ/ 90-91
 foot (body) /fʊt/ 133-16
 foot (measurement) /fʊt/ 162
 football /'fʊt,bɔːl/ 220-23, 220-27
 football helmet /'fʊt,bɔːl 'helɪmɪt/ 220-25
 forceps /'fɔːsɪps/ 194-8
 forehead /'fɔː,hed/ 133-33
 forest /'fɔːrɪst/ 169-16
 forest fire /'fɔːrɪst faɪə/ 171-1
 fork /fɔːk/ 101-21
 forklift /'fɔːk,lɪft/ 157-10
 form /fɔːm/
 registration... /,rɛdʒɪ'streɪʃən/ 43
 formal /fɔːməl/
 ...clothes /kləʊz/ 111-25
 formula /'fɔːmyələ/ 57-19, 194-19
 forty /'fɔːti/ 2
 fossil /'fɒsəl/ 185-2
 fountain /'faʊntɪn/ 58-7
 four /fɔːr/ 2
 411 /fɔːr wʌn wʌn/ 16-6
 fourteen /,fɔː'tɪn/ 2
 fourteenth /,fɔː'tɪnθ/ 3
 fourth /fɔːθ/ 3
 fox /fɒks/ 187-11
 fraction /'frækʃən/ 193-30
 fractions /'frækʃənz/ 3
 frame /freɪm/ 203-1
 freckles /'frekəl/ 33-6
 freezer /'friːzər/ 70-19
 freezing /'friːzɪŋ/ 166-7
 French /frenʃ/ 44-12
 french fries /frenʃ fraɪz/ 90-7
 French horn /frenʃ hɔːn/ 207-7
 Friday /'fraɪdeɪ/ 6-9
 frog /frɒɡ/ 182-12
 front office /frʌnt 'ɒfɪs/ 156-2
 frozen /'frəʊzən/ 77-8
 frozen foods /'frəʊzən fudz/ 99-4
 frozen vegetables /'frəʊzən 'vedʒtəbəlz/ 88-1
 frozen waffles /'frəʊzən 'wafəlz/ 88-2
 fruits /fruts/ 82-83
 frustrated /'frʌ,streɪtəd/ 39-12
fry /fraɪ/ 92-8
 frying pan /'fraɪŋ pæn/ 94-3
 full /fʊl/ 14-19, 38-9
 full moon /fʊl mun/ 177-32
 full price /fʊl praɪs/ 9-22
 funnel /'fʌnl/ 194-27
 fur /fɜːr/ 185-28
 furnace /'fɜːnɪs/ 67-5
 furnished apartment /'fɜːnɪʃd ə'pɑːtmənt/ 67-21
 furniture /'fɜːnɪʃər/
 arrange the... /ə'reɪndʒ ðə/ 64-12
 polish the... /'pɒlɪʃ ðə/ 79-9
 furniture polish /'fɜːnɪʃər 'pɒlɪʃ/ 80-9
 furniture store /'fɜːnɪʃər stɔːr/ 48-8
 galaxy /'gæləksi/ 176-7
 gallon /'gælən/ 97-21
 gallon /'gælən/ 96
 game system /geɪm 'sɪstəm/
 video... /'vɪdiəʊ/ 226-20
 games /geɪmz/ 224-225
 game show /geɪm ʃoʊ/ 209-15
 gang violence /gæŋ 'vaɪələns/ 61-13
 garage /gə'reɪʒ/ 69-16
 garage sale /gə'reɪʒ seɪl/ 216-9
 garbage can /'gɑːbrɪdʒ kæn/ 69-19, 214-9
 garbage disposal /'gɑːbrɪdʒ dɪ'spəʊzəl/ 70-17
 garbage truck /'gɑːbrɪdʒ trʌk/ 118-14
 garbanzo beans /gɑː'bʌnzəʊ biːnz/ 84-10
 garden /'gɑːdn/ 68-69, 69-21, 178-179
 weed the... /wiːd ðə/ 79-15
 gardener /'gɑːdnər/ 146-8
 garden hose /'gɑːdn haʊz/ 69-27
 garlic /'gɑːlɪk/ 85-29
 dice... /daɪs/ 92-2
 whisk... /wɪsk/ 92-3
 garment worker /'gɑːmənt 'wɜːkər/ 147-29
 gas /gæs/ 194-12
 get... /get/ 123-15
 natural... /'nætʃərəl/ 171-22
 gas gauge /gæs ɡeɪdʒ/ 121-15
 gas meter /gæs 'mɪtər/ 77-20
 gas pedal /gæs 'pedl/ 121-27
 gas station /gæs 'steɪʃən/ 47-20
 gas tank /gæs tæŋk/ 121-7
 gate /geɪt/ 69-23, 125-14
 wait at the... /weɪt ət ðə/ 126-7
 gauze /ɡɔːz/ 143-24

gazelle /gə'zɛl/ 185-15
 gearshift /'gɪər,ʃɪft/ 121-23
 gender /'dʒɛndər/ 43-5
 general practitioner /'dʒɛnərəl præk'tɪʃənər/ 141-20
 geometry /dʒi'æmətri/ 193-31
 geothermal energy /,dʒiəu'θɜ:məl 'enərʒi/ 171-25
 geraniums /dʒə'reɪniəmz/ 179-30
 German /'dʒɜ:mən/ 44-11
get /get/
 ...a speeding ticket /ə 'spɪdɪŋ 'tɪkɪt/ 123-6
 ...a job /ə ʒɒb/ 31-8
 ...a(n electric) shock /ə(n 'lɛktrɪk) ʃək/ 136-14
 ...feedback /'fɪd,bæk/ 196-23
 ...gas /gæs/ 123-15
 ...the key /ðə ki/ 64-8
 ...your boarding pass /jɔər 'bɔ:rdɪŋ pæs/ 126-4
get dressed /get drɛsd/ 34-8
get engaged /get en'geɪdʒd/ 31-11
get in /get ɪn/ 37-6
get married /get 'mæriəd/ 31-12
get off /get ɔf/ 37-14
 ...the highway /ðə 'haɪ,weɪ/ 123-9
 ...the plane /ðə pleɪn/ 126-23
get on /get ən/ 37-12
 ...the highway /ðə 'haɪ,weɪ/ 123-12
get out (of) /get aʊt (ɔv)/ 37-5
get sick /get sɪk/ 31-18
get up /get ʌp/ 34-2
 gift /gɪft/ 228-11
 give a... /gɪv ə/ 40-7
 gift shop /gɪft ʃɒp/ 48-4, 159-22
 gills /gɪlz/ 189-4
 giraffe /dʒə'ræf/ 185-6
 girdle /'gɑ:dl/ 107-21
 girl /gɜ:rl/ 57-13
give /gɪv/
 ...a gift /ə gɪft/ 40-7
 ...a shot /ə ʃɒt/ 137-25
 glacier /'glɛɪʃər/ 169-4
 glass /glæs/ 70-25
 refill the... /'rɪ,fi:l ðə/ 102-14
 water... /'wɔ:tər/ 101-16
 glass cleaner /glæs 'kli:nər/ 80-11
 glasses /glæsɪz/ 33-28, 141-24
 safety... /'seɪfti/ 157-25
 globe /'gləʊb/ 19-9
 glove compartment /glɒv kəm'pɑ:tmənt/ 121-18
 gloves /glɒvz/ 109-1
 glue /glu/ 155-25
glue /glu/ 165-24
go /gəʊ/
 ...home /həʊm/ 34-14
 ...to bed /tə bed/ 34-23
 ...to college /tə 'kɒlɪdʒ/ 31-6
 ...to the board /tə ðə bɔ:rd/ 20-16
 ...to work /tə wɜ:k/ 34-11
 goal /gəʊl/ 223-21
 goalpost /'gəʊl,pəʊst/ 220-24
 goat /gəʊt/ 152-21
go down /gəʊ daʊn/ 37-19
 goggles /'gɒgəlz/
 safety... /'seɪfti/ 157-23
go in /gəʊ ɪn/ 37-3
go into /gəʊ 'ɪntu/
 ...a dressing room /ə 'dresɪŋ rum/ 114-3
 gold /gəʊld/ 10-13
 golf /gɒlf/ 220-12
 golf club /gɒlf klʌb/ 220-13
 golf course /gɒlf kɔ:rs/ 220-15
 golfer /gɒlfər/ 220-14

goose /gʊs/ 152-19, 187-1
 gopher /'gəʊfər/ 185-19
 gorilla /gə'rɪlə/ 182-7
go shopping /gəʊ 'ʃɒpɪŋ/ 114-1
go through /gəʊ θru/
 ...security /sə'kyʊərəti/ 126-5
go up /gəʊ ʌp/ 37-20
 gown /gaʊn/ 104-5
 GP /dʒɪ pi/ 141-20
 grade /greɪd/ 19-28
graduate /'grædʒu,eɪt/
 ...from high school /frəm haɪ skul/ 31-5
 graduated cylinder /'grædʒu,eɪtɪd 'sɪləndər/ 194-20
 graduation /,grædʒu'eɪʃən/ 23-19
 graffiti /græ'fi:ti/ 61-8
 gram /græm/ 96
 grandchildren /'græn,tʃɪldrən/ 27-23
 grandfather /'græn,fɑ:dər/ 27-1
 grandmother /'græn,mʌðər/ 27-2
 grandparent /'græn,pərənt/
 become a... /bɪ'kʌm ə/ 31-21
 grandparents /'græn,pərəntz/ 27-24
 grapefruit /'greɪp,fru:t/ 83-9
 grapes /greɪps/ 83-5
 graphic artist /'græfɪk 'ɑ:tɪst/ 146-7
 grass /græs/ 69-8
 mow the... /məʊ ðə/ 79-17
 grasshopper /'græs'hɒpər/ 181-19
 grasslands /'græs,lændz/ 184-185
grate /greɪt/ 92-11
 grater /'greɪtər/ 94-13
 gray /greɪ/ 10-23
 gray hair /greɪ heər/ 33-5
grease /greɪs/ 93-26
 Greek /gri:k/ 44-15
 green /grɪn/ 10-5
 green beans /grɪn bi:nz/ 85-28
 green card /grɪn kɑ:rd/ 43-17
 greenhouse /'grɪn,haʊs/ 179-8
 green onions /grɪn 'ɒnyənz/ 85-27
greet /gri:t/ 40-2
 greeting card /'gri:tɪŋ kɑ:rd/ 52-3
grill /grɪl/ 92-6
 grill /grɪl/ 69-6, 94-4
 grizzly bear /'grɪzli beər/ 187-5
 groceries /'grəʊsərɪz/ 99-22
 ground beef /graʊnd bi:f/ 87-8
 groundhog /'graʊnd,hɒg/ 190-10
 group /grʊp/
 talk with a... /tɒk wɪð ə/ 21-20
grow /grəʊ/ 29-26, 198-5
grow up /grəʊ ʌp/ 29-27
 guest /gest/
 hotel... /hou'tel/ 159-4
 guidance counselor /'gɑ:dnɪs 'kaʊnslə/ 23-17
 guitar /gɪ'tɑ: / 207-22
 guitarist /gɪ'tɑ:ɪst/ 205-15
 gums /gʌmz/ 141-30
 gun /gʌn/
 caulking... /kɔ:kɪŋ/ 160-8
 gym /dʒɪm/ 23-4, 48-13, 67-15, 216-14
 gymnast /'dʒɪm,næst/ 218-24
 gymnastics /dʒɪm'næstɪks/ 218-23
 hacksaw /'hæk,sɔ/ 160-11
 hail /heɪl/ 166-18
 hailstone /'heɪl,stəʊn/ 166-21
 hair /heər/ 32-33, 133-32
 comb... /kəʊm/ 34-5
 hairbrush /'heər,bɾʌʃ/ 144-10
 hairdresser /'heər,dresər/ 146-5

- hair dryer /hɛr 'draɪər/ 144-6
 hair gel /hɛr dʒel/ 144-4
 hairnet /'hɛr,net/ 157-20
 hair salon /hɛr sə'lan/ 48-11
 hairspray /'hɛr,spreɪ/ 144-1
 hairstylist /'hɛr,stɑɪlɪst/ 146-5
 half /hæf/ 3
 half dollar /hæf 'dɒlə/ 8-5
 half past six /hæf pæst sɪks/ 5
 half sister /hæf sɪstər/ 27-13
 halibut /'hæləbət/ 189-30
 Halloween /,hælə'wɪn/ 228-13
 hallway /'hɒl,weɪ/ 67-12
 ham /hæm/ 87-4
 hamburger /'hæm,bɜːgər/ 90-4
hammer /'hæmə/ 165-9
 hammer /'hæmə/ 160-9
 hammock /'hæmək/ 69-7
 hand /hænd/ 133-4
 raise your... /reɪz jər/ 20-1
 handbag /'hænd,bæɡ/ 109-2
 hand cream /hænd kɪm/
 tube of... /tʌb ʌv/ 97-9
 handcuffs /'hænd,kʌfs/ 61-19
 handheld (computer) /'hænd,held (kəm'pyutər)/ 25-16
 handicapped parking space /'hændɪ,kæpt pɑːkɪŋ speɪs/ 58-14.
hand in /hænd ɪn/
 ...your paper /jər 'peɪpər/ 20-2
 hand mixer /hænd 'mɪksər/ 95-19
hand out /hænd aʊt/
 ...papers /'peɪpəz/ 21-18
 handsaw /'hænd,sɔː/ 160-6
 hand tools /hænd tuːlz/ 160
 hand truck /hænd trʌk/ 157-19
 handyman /'hændɪ,mæn/ 77-17
hang /hæŋ/ 183-28
hang (up) /hæŋ (ʌp)/ 115-24
 hanger /'hæŋər/ 117-11
hang up /hæŋ ʌp/
 ...the phone /ðə fəʊn/ 17-29
 happy /'hæpi/ 38-2
 hard /hɑːd/ 14-9
 hardcover (book) /'hɑːd,kʌvər (bʊk)/ 55-13
 hard hat /hɑːd hæt/ 156-8
 hardware /'hɑːd,wɛr/ 163
 harmonica /hɑː'manɪkə/ 207-17
 harp /hɑːp/ 207-24
 hat /hæt/ 104-17
 hard... /hɑːd/ 156-8
 knit... /nɪt/ 109-26
have /hæv/
 ...a conversation /ə ,kɒnvər'seɪʃən/ 17-28, 40-6
 ...a flat tire /ə flæt taɪr/ 123-21
 ...a heart attack /ə hɑːt ə'tæk/ 136-13
 ...an accident /ən 'æksɪdənt/ 123-19
 ...an allergic reaction /ən ə'lɜːdʒɪk rɪ'ækʃən/ 136-12
 ...breakfast /'brekfəst/ 34-9
 ...dinner /'dɪnər/ 34-19
 ...lunch /lʌnʃ/ 34-13
have a baby /hæv ə 'beɪbi/ 31-15
 hawk /hɔːk/ 181-1
 hay /heɪ/ 152-13
 hazardous waste /'hæzərədəs weɪst/ 171-18
 head /hed/ 133-19
 headache /'hed,eɪk/ 135-13
 headlight /'hed,laɪt/ 121-37
 headlights /'hed,laɪts/
 turn on the... /tɜːn ən ði/ 123-7
 headline /'hed,laɪn/ 55-18
 headphones /'hed,fəʊnz/ 226-11
 put on your... /put ən jər/ 126-16
 headset /'hed,set/ 16-16
 healing /'hiːlɪŋ/ 136-137
 HEALTH /helθ/ 132-145
 health aide /helθ eɪd/ 146-21
 health club /helθ klʌb/ 48-13
hear /hɪr/ 17-26
 heart /hɑːt/ 133-26, 224-10
 heart attack /hɑːt ə'tæk/
 have a... /hæv ə/ 136-13
 heater /'hiːtər/ 121-20
 ...doesn't work /'dʌzənt wɜːk/ 77-7
 heating pad /'hiːtɪŋ pæd/ 142-21
 heavy /hevi/ 14-23, 15-25
 ...jacket /'dʒækɪt/ 111-2
 hedge clippers /hedʒ 'klɪpəz/ 69-25
 heel /hil/ 133-17
 high... /haɪ/ 109-17
 heels /hɪlz/
 high... /haɪ/ 111-22
 low... /ləʊ/ 111-23
 height /haɪt/ 193
 helicopter /'helɪ,kɑːptər/ 125-12
 helmet /'helɪmt/
 football... /'fʊtbɔːl/ 220-25
help /help/ 29-16, 40-19
 hem /hem/ 117-18
 high /haɪ/
 ...heels /hɪlz/ 111-22
 high chair /haɪ tʃeər/ 57-18, 101-17
 high heel /haɪ hɪl/ 109-17
 high rise (building) /haɪ raɪz ('bɪldɪŋ)/ 47-22
 high school /haɪ skuːl/
 graduate from... /'grædʒu,eɪt frəm/ 31-5
 high school diploma /haɪ skuːl dɪ'plɒmə/ 43-28
 highway /'haɪ,weɪ/
 get off the... /get ɒf ðə/ 123-9
 get on the... /get ən ðə/ 123-12
hike /haɪk/ 213-31
 hiker /'haɪkər/ 213-4
 hiking boot /'haɪkɪŋ buːt/ 109-24
 hiking trail /'haɪkɪŋ treɪl/ 213-14, 216-11
 hill /hɪl/ 169-22
 hinge /hɪŋdʒ/ 163-25
 hip /hɪp/ 133-12
 hip hop /hɪp hɒp/ 209-27
 hippopotamus /,hɪpə'pɒtəməs/ 185-7
hire /haɪr/ 150-13
 hobbies /'hɒbɪz/ 224-225
 hockey /'hɒki/
 ice... /aɪs/ 223-17
 hockey player /'hɒki 'pleɪər/ 223-22
 hockey puck /'hɒki pʌk/ 223-24
 hockey stick /'hɒki stɪk/ 223-23
hold /həʊld/ 29-4
 hole /həʊl/
 drill a... /drɪl ə/ 165-4
 hole punch /həʊl pʌnʃ/ 155-30
 holidays /'hɒlə,deɪz/ 228-229
 home /həʊm/
 go... /ɡəʊ/ 34-14
 home attendant /həʊm ə'tendənt/ 146-21
 home health aide /həʊm helθ eɪd/ 146-21
 homemaker /'həʊm,meɪkər/ 146-13
 homesick /'həʊm,sɪk/ 39-16
 homework /'həʊm,wɜːk/
 do... /du/ 34-17
 homework assignment /'həʊm,wɜːk ə'saɪnmənt/ 19-5
 honey /'hʌni/
 jar of... /dʒɑː ʌv/ 97-24

honk /hɒŋk/ 123-14
hood /hʊd/ 121-30
hoof /hʊf/ 185-22
hook /hʊk/ 163-27
hop /hɒp/ 183-27
horn /hɔːn/ 121-21, 185-23
 honk the... /hɒŋk ðə/ 123-14
hornet /'hɔːnɪt/ 190-26
horror /'hɔːrər/ 208-9
horse /hɔːs/ 152-22
horseback rider /'hɔːs,bæk 'raɪdər/ 213-3
hose /həʊz/
 garden... /'gɑːdn/ 69-27
hospital /'hɒspɪtl/ 47-8, 118-3, 138-139
hospital gown /'hɒspɪtl gaʊn/ 139-20
hot /hɒt/ 15-29, 166-3
hot dog /hɒt dɒg/ 90-8
hotel /həʊ'tel/ 58-1, 158-159
hotel guest /həʊ'tel gest/ 159-4
hour /'aʊər/ 4
house /haʊs/ 63-1, 68-69
 buy a... /baɪ ə/ 31-13
 inspect the... /ɪn'spekt ðə/ 65-21
 wire a... /waɪ ə/ 165-8
houseboat /'haʊs,bɔ:t/ 63-13
household chores /'haʊs,həʊld tʃɔːz/ 78-79
household cleaners /'haʊs,həʊld 'kli:nəz/ 99-9
household problems /'haʊs,həʊld 'prɒbləmz/ 76-77
housekeeper /'haʊs,kɪpər/ 146-15, 159-1
housekeeping cart /'haʊs,kɪpɪŋ kɑːt/ 159-2
House of Representatives /'haʊs əv ,reprə'zɛntətɪvz/ 201
housepainter /'haʊs,pɛɪntər/ 148-14
house payment /'haʊs 'peɪmənt/
 make the... /meɪk ðə/ 65-26
house plant /'haʊs,plɑːnt/ 72-29
houses /'haʊzɪz/
 look at... /lʊk ət/ 65-17
housework /'haʊs,wɜːk/
 do... /du/ 34-21
HOUSING /'haʊzɪŋ/ 62-81
hug /hʌg/ 40-17
human body /'hyʊmən 'bɒdi/ 132-133
humidifier /'hyʊmɪdə,fɑɪər/ 143-32
hummingbird /'hʌmɪŋ,bɜːd/ 182-10
hungry /'hʌŋgrɪ/ 38-10
hurricane /'hʌrə,keɪn/ 171-8
hurting /'hɜːtɪŋ/ 136-137
husband /'hʌzbænd/ 27-18
hydrant /'haɪdrənt/
 fire... /faɪə/ 58-11
hydroelectric power /,haɪdrəʊ'lektrɪk 'paʊər/ 171-29
hydrogen peroxide /'haɪdrədʒən pə'rɒksaɪd/ 142-22
hyena /haɪ'ɪnə/ 185-5
hygienist /haɪ'dʒɪnɪst/
 dental... /'dentl/ 141-25
hyphen /'haɪfən/ 196-19
ice /aɪs/ 166-24
iceberg /'aɪs,bɜːg/ 187-10
ice cream /aɪs kɪrɪm/ 88-3
ice cream stand /aɪs kɪrɪm stænd/ 48-28
iced tea /aɪsd ti/ 88-9
ice hockey /aɪs 'hɒki/ 223-17
ice pack /aɪs pæk/ 143-33
ice (skating) rink /aɪs ('skeɪtɪŋ) rɪŋk/ 223-20
ice skater /aɪs 'skeɪtər/ 222-10
ice skates /aɪs 'skeɪts/ 223-25
ice skating /aɪs 'skeɪtɪŋ/ 222-9
ice tray /aɪs treɪ/ 88-4
icons /'aɪ,kɒnz/ 25-9
ID /'aɪ'di/
 photo... /'fəʊtəʊ/ 124-3
 show your... /ʃəʊ jəː/ 126-2
 student... /'stʊdnt/ 43-19
Ideas /aɪ'diːz/
 brainstorm... /'breɪn,stɔːm/ 196-20
 discuss your... /dɪ'skʌs jəː/ 20-11
igloo /'ɪɡluː/ 63-15
ignition /ɪɡ'nɪʃən/ 121-22
ill /ɪl/ 39-14
Illnesses /'ɪlnəsɪz/ 134-135
immigrate /'ɪmɪ'ɡreɪt/ 31-4
Immigration /,ɪmɪ'ɡreɪʃən/ 125-20
in /ɪn/ 13-5
inch /ɪntʃ/ 163-1
indentation /,ɪndən'teɪʃən/ 196-6
Independence Day /,ɪndə'pendəns deɪ/ 228-7
Indian /'ɪndiən/ 44-22
indoor sports and fitness /'ɪn,dɔː spɔːts ənd 'fɪtnɪs/ 218-219
infant /'ɪnfənt/ 30, 56-32
Informal /ɪn'fɔːməl/
 ...clothes /kloʊz/ 111-24
Information /,ɪnfə'meɪʃən/ 16-6
in front of /ɪn frʌnt əv/ 13-17
inhaler /ɪn'həʊlər/ 142-11
Injuries /'ɪn dʒərɪz/ 134-135
In-line skates /'ɪn-laɪn skeɪts/ 214-24
in love /ɪn lʌv/ 38-8
insect repellent /'ɪnsɛkt rə'pelənt/ 213-22
insect spray /'ɪnsɛkt spreɪ/ 80-15
insert /ɪn'sɜːt/ 51-24
inside /'ɪn,sɑɪd/ 13-5
Inside the refrigerator /'ɪn,sɑɪd ðə rɪ'frɪdʒə'reɪtər/ 88-89
inspect /ɪn'spekt/
 ...the house /ðɪ haʊs/ 65-21
install /ɪn'stɔːl/ 165-13
Instructor /ɪn'strʌktər/ 148-9
Instruments /'ɪnstrə'mənts/ 206-207
insulation /,ɪnsə'leɪʃən/ 163-6
intensive care unit /ɪn'tensɪv keə 'juːnɪt/ 138-3
Intercom /'ɪntər,kəm/ 67-30
Interest /'ɪntrɪst/ 51-15
interested /'ɪntrɪstɪd/ 38-4
International call /,ɪntər'næʃənəl kɔːl/ 16-11
Internet /'ɪntər,net/ 25-29
Intersection /'ɪntər,sekʃən/ 47-26
into /'ɪntu/ 130-3
Intravenous drip /,ɪntrə'veɪnəs drɪp/ 138-4
introduce /,ɪntrə'dʊs/ 40-15
introduces /,ɪntrə'dʊsɪz/ 198-17
invents /ɪn'vents/ 198-12
invite /ɪn'vaɪt/ 40-23
Iranian /'ɪræniən/ 44-17
Irises /'aɪrɪsɪz/ 179-19
Iron /'aɪərən/ 115-23
Iron board /'aɪərən bɔːd/ 116-1
island /'aɪlənd/ 169-8
Italian /'ɪtæliən/ 44-14
IV /'aɪ'vi/ 138-4
Ivory /'aɪvəri/ 10-21
Ivy /'aɪvi/ 179-27
Jack /dʒæk/ 121-2, 224-5
jackpot /'dʒækɪt/ 104-16
 heavy... /'hevi/ 111-2
 light... /laɪt/ 111-1
Jack-o-lantern /'dʒæk-ə-,ləntərən/ 229-15
Jail /dʒeɪl/ 61-26
Jam /dʒæm/ 88-17
Jammed /dʒæmd/ 77-11
Janitor /'dʒænətər/ 146-11

- January /'dʒænjuəri/ 7-16
 Japanese /dʒæpə'niz/ 44-25
 jar /dʒɑːr/ 97-24
 jazz /dʒæz/ 209-23
 jeans /dʒiːnz/ 104-27
 flared... /flɛəd/ 111-10
 straight leg... /streɪt leɡ/ 111-11
 jellyfish /'dʒeliːfɪʃ/ 189-11
 jewelry /'dʒuələri/ 109-13
 jewelry store /'dʒuələri stɔːr/ 48-5
 job /dʒɒb/
 ge`a... /get ə/ 31-8
 jobs /dʒɒbz/ 146-149
 jockstrap /'dʒɒkstræp/ 107-28
 jog /dʒɒg/ 37-9
 jogger /'dʒɒgə/ 214-20
 joker /'dʒɒkə/ 224-6
 judge /dʒʌdʒ/ 61-23
 Judicial branch /dʒuːdɪʃəl brænʃ/ 201
 July /dʒuːlaɪ/ 7-22
 jump /dʒʌmp/ 37-24
 jumper cables /'dʒʌmpə 'keɪbəlz/ 121-34
 June /dʒun/ 7-21
 jungle gym /'dʒʌŋɡəl dʒɪm/ 214-6
 Jupiter /'dʒʊpətə/ 176-24
 jury /'dʒʊəri/ 61-22
 serve on a... /sɜːv ən ə/ 201-17
 justice /'dʒʌstɪs/ 60-61
 justices /'dʒʌstɪsəz/ 200-13
 kangaroo /,kæŋɡə'ru/ 185-4
 ketchup /'ketʃəp/ 90-16
 kettle /'ketl/ 70-7
 key /ki/ 25-18, 67-31
 keyboard /'ki:bɔːrd/ 25-21, 207
 electric... /i'lektɪk/ 207-25
 key chain /ki tʃeɪn/ 109-29
 kidney /'kɪdni/ 133-30
 kidney beans /'kɪdni biːnz/ 84-18
 killer whale /'kɪlə weɪl/ 189-7
 kilogram /'kɪləgræm/ 96
 kilometer /ki'lɪmɪtə/ 162
 king /kɪŋ/ 224-3
 kiss /kɪs/ 40-21
 kitchen /'kɪtʃən/ 70-71
 kitchen timer /'kɪtʃən 'taɪmər/ 94-7
 kite /kaɪt/ 214-1
 kiwi /'kiwi/ 83-2
 knee /ni/ 133-45
 knee brace /ni breɪs/ 142-18
 kneel /neɪl/ 37-22
 knife /naɪf/ 101-24
 pocket... /'pɒkɪt/ 213-21
 knit /nɪt/ 224-25
 knit hat /nɪt hæʔ/ 109-26
 knitting needles /'nɪtɪŋ 'niːdlz/ 224-20
 koala /kou'ələ/ 185-3
 Korean /kə'reɪən/ 44-24
 lab /ləb/ 139-14
 label /'leɪbəl/ 155-32
 laboratory /'læbrətɔːri/ 139-14
 lab technician /ləb tek'nɪʃən/ 139-15
 lace /leɪs/ 113-11
 ladder /'lædə/ 113-11
 climb a... /klaɪm ə/ 165-14
 ladle /'leɪdl/ 94-11
 ladybug /'leɪdɪbʌɡ/ 190-27
 lake /leɪk/ 169-7
 lamb /læm/ 86
 leg of... /leɡ əv/ 87-2
 lamb chops /læm tʃɒps/ 87-1
 lamp /læmp/ 72-5
 lampshade /'læmpʃeɪd/ 72-6
 land /lænd/ 126-21
 landlord /'lænd,lɔːrd/
 meet the... /mɪt ðə/ 64-3
 landscape /'lændskeɪp/ 203-4
 language lab /'læŋɡwɪdʒ læb/ 23-3
 lantern /'læntərn/ 213-16
 laptop (computer) /'læp,tɒp (kəm'pyutə)/ 25-23
 large /lɑːdʒ/ 14-2
 lasagna /lə'zɑːnyə/ 90-2
 last name /læst neɪm/ 43-2
 latex gloves /'leɪ,teks glɒvz/ 139-12
 launches /lɒnʃeɪz/ 198-15
 laundromat /'lɒndrə,mæt/ 48-23
 laundry /'lɒndri/ 116-117
 do the... /du ðə/ 79-3
 laundry basket /'lɒndri 'bæskɪt/ 116-10
 laundry detergent /'lɒndri dɪ'tɜːrdʒənt/ 116-4
 laundry room /'lɒndri ru:m/ 67-18
 law /lə/
 obey the... /ou'beɪ ðə/ 201-15
 lawn /lɔːn/ 69-8
 mow the... /mou ðə/ 79-17
 water the... /'wɔːtə ðə/ 79-18
 lawn mower /lɔːn mouə/ 69-9
 lawyer /'lɔːyə/ 61-24, 148-3
 lay /leɪ/
 ...bricks /'brɪks/ 165-5
 lead /liːd/ 37-18
 leaf /liːf/ 179-13
 leaks /liːks/ 77-3
 learn /lɜːn/ 31-2
 lease /liːs/
 sign the... /saɪn ðə/ 64-6
 leather /'leðə/ 113-5
 leave /liːv/ 37-2, 123-2
 ...a tip /ə tɪp/ 102-23
 leaves /liːvz/
 rake the... /reɪk ðə/ 79-20
 lecture /'lektʃə/ 216-12
 left /left/ 130-15
 leg /leɡ/ 133-14
 break a... /breɪk ə/ 136-5
 Legislative branch /'leʒɪs,lɛɪtɪv brænʃ/ 201
 leg of lamb /leɡ əv læm/ 87-2
 legs /leɡz/ 87-33
 lemon /'lemən/ 83-14
 lemonade /,lemən'eɪd/
 pitcher of... /'pɪtʃə əv/ 97-14
 lens /leɪnz/
 contact... /'kɒn,tækt/ 141-22
 leopard /'lepərd/ 185-11
 leotard /'liə,tɑːd/ 107-18
 letter /'letə/ 52-2, 196-1
 write a... /raɪt ə/ 40-8
 letter carrier /'letə 'kæriə/ 52-10
 letterhead /'letə,hed/ 155-13
 lettuce /'letəs/ 84-5
 level /'levəl/ 160-16
 librarian /laɪ'brɛəriən/ 55-11
 library /'laɪbrəri/ 47-18, 54-55
 school... /skul/ 23-7
 library card /'laɪbrəri kɑːd/ 55-12
 lice /laɪs/ 135-4
 license plate /'laɪsəns pleɪt/ 121-8
 lid /lɪd/ 94-6
 life events /laɪf i'vents/ 30-31
 lifeguard /'laɪf,gɑːd/ 211-17
 life jacket /laɪf 'dʒækt/ 211-14

- light** /laɪt/ 102-3
 ...candles /'kændlɪs/ 229-30
- light** /laɪt/ 14-24
 ...jacket /'dʒækɪt/ 111-1
- lightbulb** /'laɪtbʌlb/ 160-22
 ...is burned out /ɪz 'bɜːnd aʊt/ 77-6
- lighthouse** /'laɪt,haʊs/ 211-7
- lightning** /'laɪtnɪŋ/ 166-15
- lights** /laɪts/ 229-21
- light switch** /laɪt swɪtʃ/ 72-24
- lilac bush** /'laɪ,læk bʊʃ/ 179-7
- lilies** /'lɪlɪz/ 179-20
- lima beans** /'laɪmə bɪnz/ 84-21
- lime** /laɪm/ 83-20
- lime green** /laɪm grɪn/ 10-7
- limo** /'lɪmoʊ/ 118-18
- limousine** /,lɪmə'zɪn/ 118-18
- line** /laɪn/ 125-21
 curved... /kɜːrvd/ 193-8
 straight... /streɪt/ 193-7
 subway... /'sʌb,weɪ/ 128-16
 wait in... /weɪt ɪn/ 51-23
- linen** /'lɪnən/ 113-7
- lines** /laɪnz/
 parallel... /'pærə,leɪl/ 193-12
 perpendicular... /,pɜːpərən'dɪkjʊləɹ/ 193-11
- lion** /'laɪən/ 185-20
- lip** /lɪp/ 133-42
- lipstick** /'lɪp,stɪk/ 144-27
- liquid** /'lɪkwɪd/ 194-11
- listen** /'lɪsən/ 20-12, 126-17
- liter** /'lɪtər/ 97-17
- liter** /'lɪtər/ 96
- litter** /'lɪtər/ 171-21
- little** /'lɪtl/ 14-1
- liver** /'lɪvər/ 87-12, 133-28
- living room** /'lɪvɪŋ rʊm/ 72-73
- lizard** /'lɪzərd/ 181-10
- load** /ləʊd/ 150-6
 ...a van or truck /ə væn ɔr trʌk/ 64-10
- loading dock** /ləʊdɪŋ dɒk/ 157-18
- loaf** /ləʊf/ 97-16
- loafer** /'ləʊfər/ 109-19
- loan** /ləʊn/ 65-22
- loan documents** /ləʊn 'dɒkjʊmənts/
 sign the... /saɪn ðə/ 65-24
- loan officer** /ləʊn 'ɔfɪsər/ 51-9
- lobby** /'lɒbi/ 67-22, 159-9
- lobster** /'lɒbstər/ 87-14
- local call** /'ləʊkəl kɔl/ 16-9
- lock** /lɒk/
 dead-bolt... /ded-bəʊlt/ 67-28
 ...is jammed /ɪz dʒæmɪd/ 77-11
- locker** /'lɒkər/ 23-14
- locker room** /'lɒkər rʊm/ 218-35
- locksmith** /'lɒk,smɪθ/ 77-22, 148-7
- log cabin** /lɒg 'kæbɪn/ 63-4
- lonely** /'ləʊnli/ 39-17
- long** /lɒŋ/
 ...skirt /skɜːrt/ 111-21
- long-distance call** /lɒŋ-'dɪstəns kɔl/ 16-10
- long hair** /lɒŋ heə/ 33-13
- long-sleeved** /lɒŋ-sli:vɪd/
 ...shirt /ʃɜːt/ 111-5
- long underwear** /lɒŋ 'ʌndər,weɪr/ 107-15
- look at** /lʊk ət/
 ...a map /ə mæp/ 123-11
 ...houses /haʊsez/ 65-17
 ...the menu /ðə 'menyu/ 102-7
- look for** /lʊk fər/
 ...a book /ə bʊk/ 54-26
 ...a jacket /ə dʒækɪt/ 114-2
 ...an apartment /ən ə'pɑːtmənt/ 64-1
- look up** /lʊk ʌp/
 ...a word /ə wɜːd/ 20-8
- loose** /luːs/
 ...pants /pænts/ 111-12
- lofton** /'ləʊfən/ 144-23
 baby... /'beɪbi/ 57-23
- loud** /ləʊd/ 15-35
- loudspeaker** /'ləʊd,spɪkər/ 23-13
- love** /lʌv/ 29-1
- love seat** /lʌv siːt/ 72-11
- low** /ləʊ/
 ...heels /hiːlz/ 111-23
- lozenges** /'ləʊzəndʒez/ 142-9
- luggage** /'lʌɡɪdʒ/ 124-5
- luggage cart** /'lʌɡɪdʒ kɑːt/ 159-16
- lumber** /'lʌmbər/ 163
 board... /bɔːrd/ 163-30
- lunch** /lʌnʃ/
 eat... /ɪt/ 34-13
 have... /hæv/ 34-13
- lung** /lʌŋ/ 133-27
- machine operator** /mə'ʃɪn 'ɒpə,reɪtər/ 157-14
- magazine** /,mægə'zɪn/ 55-2
- magnet** /'mæɡnɪt/ 194-30
- magnifying glass** /'mæɡnə,faiŋ glæs/ 194-26
- mah-jongg** /'mɑːʒŋŋ/ 224-13
- mail** /meɪl/ 53-24
- mail** /meɪl/
 open... /'oʊpən/ 150-5
- mailbox** /'meɪl,bɒks/ 52-9
- mail carrier** /meɪl 'kæriər/ 52-10
- mailing address** /'meɪlɪŋ 'ə'dres/ 52-6
- mail truck** /meɪl trʌk/ 52-11
- main course** /meɪn kɔːrs/ 101-27
- make** /meɪk/
 ...a decision /ə dɪ'sɪʒən/ 65-18, 151-26
 ...a deposit /ə dɪ'pɒzɪt/ 51-27
 ...a down payment /ə daʊn 'peɪmənt/ 65-23
 ...an appointment /ən ə'pɒɪntmənt/ 64-2, 137-21
 ...an offer /ən 'ɔfər/ 65-19
 ...a reservation /ə ,rezər'veɪʃən/ 102-1, 159-24
 ...copies /'kɒpɪz/ 151-20
 ...dinner /'dɪnər/ 34-18
 ...the bed /ðə bed/ 79-1
 ...the (house) payment /ðə (haʊs) 'peɪmənt/ 65-26
- makeup** /'meɪk,ʌp/ 144
- Malaysian** /mə'leɪʒən/ 44-29
- male** /meɪl/ 42
- mall** /mɔːl/ 47-3
- man** /mæn/ 15-39
- manage** /'mænɪdʒ/ 151-18
- mane** /meɪn/ 185-26
- mango** /'mæŋɡoʊ/ 83-8
- manicurist** /'mæni,kjʊrɪst/ 148-2
- mantle** /'mæntəl/ 72-26
- manufacture** /,mænyə'fæktʃər/ 151-23
- map** /mæp/ 19-12
 look at a... /lʊk ət ə/ 123-11
 trail... /treɪl/ 213-18
- maple (tree)** /'meɪpəl (tri)/ 179-4
- maracas** /mə'rakəz/ 207-5
- march** /mɑːʃ/ 37-4
- March** /mɑːʃ/ 7-18
- margarine** /'mɑːdʒərɪn/ 88-6
- margin** /'mɑːdʒɪn/ 196-7
- marigolds** /'mæɹə,gəʊldz/ 179-26
- marimba** /mə'rɪmbə/ 207-4

marinate /'mæɹə,neɪt/ 92-5
marker /'mɑ:kə/ 19-15
maroon /mə'ru:n/ 10-2
marriage certificate /'mæɹɪdʒ sər'tɪfɪkət/ 43-25
married /'mæɹɪd/ 26-27
Mars /mɑ:z/ 176-25
martial arts /'mɑ:ʃəl ɑ:ts/ 218-1
mascara /mæ'skæɹə/ 144-30
mask /mæsk/ 204-4
 diving... /'daɪvɪŋ/ 211-26
 surgical... /'sɜ:dʒɪkəl/ 139-13
masking tape /'mæskɪŋ teɪp/ 163-13
match /mætʃ/ 21-22
matches /mætʃəz/ 213-23
maternity dress /mæ'tɜ:nəti dres/ 104-24
math /mæθ/ 192-193
mattress /'mætrɪs/ 74-13
 air... /eɪ/ 213-26
May /meɪ/ 7-20
mayonnaise /'meɪə,neɪz/ 88-7
meal /mil/
 choose a... /ʃu:z ə/ 126-20
measles /'mizəlz/ 135-9
measure /'meʒə/ 92-1, 165-11
measurements /'meʒərmənts/ 96-97
measuring cups /'meʒəɹɪŋ kʌps/ 95-23
measuring spoons /'meʒəɹɪŋ spunz/ 95-24
meat /mit/ 86-87
meats /mits/ 99-2
meat thermometer /mit θɜ:'mɑ:mətə/ 94-17
mechanic /mə'kænɪk/ 148-10
medical center /'medɪkəl 'sentə/ 140-141
medical chart /'medɪkəl tʃɑ:t/ 141-2
medicine cabinet /'medəsən 'kæbənɪt/ 75-21
meet /mit/
 ...the landlord /ðə 'lænd,lɔ:rd/ 64-3
 ...the neighbors /ðə 'neɪbəz/ 64-15
meeting room /'mi:tɪŋ rum/ 159-6
melons /'melənz/
 crate of... /kreɪt ɔv/ 97-30
mend /mend/ 115-21
menu /'menyu/ 101-20
 drop down... /drɒp daʊn/ 25-8
 look at the... /lʊk ət ðə/ 102-7
Mercury /'mɜ:kyəri/ 176-28
merry-go-round /'mɛri-gou-raʊnd/ 214-14
mesa /'meɪsə/ 169-15
message /'mesɪdʒ/
 e-mail... /'i:,meɪl/ 25-22
 take a... /teɪk ə/ 150-12
metal detector /'metl dɪ'tektə/ 125-9
meteor /'mi:tɪə/ 176-16
meter /'mi:tə/ 128-2
 parking... /'pɑ:kɪŋ/ 58-20
meter reader /'mi:tə 'ri:də/ 77-21
methods of payment /'meθədz ɔv 'peɪmənt/ 9
Mexican /'meksɪkən/ 44-3
mice /maɪs/ 76-24
microfilm machine /'maɪkrə,fɪlm mə'ʃɪn/ 55-3
microphone /'maɪkrə,fəʊn/ 205-13
microscope /'maɪkrə,skəʊp/ 194-25
microwave /'maɪkrə,weɪv/ 92-13
microwave (oven) /'maɪkrə,weɪv ('ɔvən)/ 70-1
Mid-Atlantic States /mɪd-ət'læntɪk steɪts/ 172-10
midday /'mɪd,deɪ/ 5
middle initial /'mɪdl 'ɪnɪʃəl/ 43-4
midnight /'mɪd,naɪt/ 5
Midwest /'mɪd'west/ 172-9
migrate /'maɪ,greɪt/ 198-1
mile /maɪl/ 162

military /'mɪlə,terɪ/
 serve in the... /sɜ:v ɪn ðə/ 201-19
milk /mɪlk/ 153-32
milk /mɪlk/ 88-26
 quart of... /kwɔ:t ɔv/ 97-18
millennium /mɪ'lenɪəm/ 4
miniature golf /'mɪniəʃə gɔlf/ 216-16
minivan /'mɪnɪvæn/ 118-17
minus /'maɪnəs/ 193-2
minute /'mɪnɪt/ 4
mirror /'mɪrə/ 74-7
misbehave /,mɪsbɪ'heɪv/ 29-25
mittens /mɪtnz/ 109-3
mix /mɪks/ 93-29
mixer /'mɪksə/
 hand... /hænd/ 95-19
mixing bowl /'mɪksɪŋ 'bəʊl/ 94-12
mobile home /'məʊbəl haʊm/ 63-7
mobile phone /'məʊbəl fəʊn/ 16-20
model /'mɒdl/ 203-5
 build a... /bɪld ə/ 224-28
molding /'məʊldɪŋ/ 163-29
mole /məʊl/ 33-27, 190-16
molecule /'mɒlɪ,kyul/ 194-18
Monday /'mɒn,deɪ/ 6-5
money /'mʌni/ 8-9, 51-6
money order /'mʌni 'ɔ:də/ 51-19
monitor /'mɒnətə/ 25-19
monitors /'mɒnətəz/
 check the... /tʃek ðə/ 126-6
monkey /'mʌnki/ 182-6
monkey bars /'mʌnki bɑ:z/ 214-3
month /mʌnθ/ 4
monthly statement /'mʌnθli 'steɪtmənt/ 51-10
months of the year /mʌnθs ɔv ðə jɪr/ 7
monument /'mɒnyəmənt/ 58-10
moon /mun/ 176-12
 crescent... /kresənt/ 177-30
 full... /fʊl/ 177-32
 new... /nu/ 177-29
 quarter... /'kwɔ:tə/ 177-31
moose /mus/ 187-2
mop /mɒp/ 79-12
mop /mɒp/ 80-26
morning /'mɔ:rnɪŋ/ 5
mosque /'mɒsk/ 47-5
mosquito /mɒ'skɪtəʊ/ 190-24
moss /mɒs/ 187-6
motel /məʊ'tel/ 47-4
moth /mɒθ/ 181-21
mother /'mʌðə/ 27-7
 single... /'sɪŋɡəl/ 27-29
mother-in-law /'mʌðə-ɪn-,lə/ 27-9
Mother's Day /'mʌðəz deɪ/ 228-10
motor /'məʊtə/ 121-32
motorboat /'məʊtə,bəʊt/ 211-4
motorcycle /'məʊtə,sʌɪkəl/ 118-32
mountain /'maʊntn/ 169-2
mountain lion /'maʊntn 'laɪən/ 181-5
mouse /maʊs/ 25-27, 190-29
mouse pad /maʊs pæd/ 25-26
mousetrap /'maʊs,tɹæp/ 80-24
mouth /maʊθ/ 133-41
 ...of the river /ɔv ðə 'rɪvə/ 169-19
move /mu:v/ 31-17
move in /mu:v ɪn/ 65-25
movie theater /'mu:vi θiətə/ 47-12, 216-22
now /naʊ/ 79-17
MP3 player /,em'pi θri 'pleɪə/ 226-9
mudslide /'mʌdslaɪd/ 171-9

- muffin /'mʌfɪn/ 90-14
 mug /mʌg/ 70-30
 mugging /'mʌgɪŋ/ 61-9
 multiplication /,mʌltɪplə'keɪʃən/ 193-28
 multiplied by /'mʌltə'plaɪd baɪ/ 193-5
 mumps /mʌmps/ 135-7
 mural /'myʊərəl/ 203-15
 murder /'mɜːdə/ 61-10
 muscle /'mʌsəl/ 133-2
 museum /'myuːziəm/ 59-24, 216-20
 mushroom /'mʌʃ,rʊm/ 85-32
 music /'myuzɪk/ 209
 listen to... /'lɪsən tə/ 126-17
 musician /'myuːzɪʃən/ 148-24
 music store /'myuzɪk stɔː/ 48-10
 mussel /'mʌsəl/ 189-27
 mussels /'mʌsəlz/ 87-17
 mustache /'mʌ,stæʃ/ 33-8
 mustard /'mʌstərd/ 90-17
 mystery /'mɪstəri/ 208-3
 nail /neɪl/ 163-20
 hammer a... /'hæmə ə/ 165-9
 nail clipper /neɪl 'klɪpər/ 144-12
 nail polish /neɪl 'pɒlɪʃ/ 144-11
 nail salon /neɪl sə'lɒn/ 48-16
 name /neɪm/ 43-1
 spell your... /spɛl jə/ 20-13
 write your... /raɪt jə/ 20-6
 nap /næp/
 take a... /teɪk ə/ 34-15
 napkin /'næpkɪn/ 70-31, 101-22
 narrow /'nærəʊ/
 ...tie /taɪ/ 111-9
 nasal (decongestant) spray /'neɪzəl (,dɪkən'ʤestənt) spreɪ/
 142-12
 nationalities /,næʃə'nælətɪz/ 44-45
 natural disasters /'nætʃərəl dɪ'zæstəz/ 170-171
 natural gas /'nætʃərəl ɡæz/ 171-22
 nature program /'neɪtʃər 'prəʊ,ɡræm/ 209-18
 nauseous /'nɔːsəs/ 135-19
 navy (blue) /'neɪvi (blu)/ 10-11
 near /nɪr/ 13-15
 neck /nek/ 133-20
 necklace /'neklɪs/ 109-8
 needle /'niːdl/ 117-29, 224-24
 negotiate /nɪ'ɡəʊʃɪ,eɪ/
 ...the price /ðə praɪs/ 65-20
 neighbors /'neɪbəz/
 meet the... /miːt ðə/ 64-15
 nephew /'nefju/ 27-20
 Neptune /'neptun/ 176-21
 nervous /'nɜːrvəs/ 38-6
 nest /nest/ 190-3
 net /net/ 25-29
 volleyball... /'vɒli,bɔːl/ 220-11
 new /nu/ 15-31
 newborn /'nu,bɔːn/ 56-31
 New England /nu 'ɪŋɡlənd/ 172-11
 new moon /nu muːn/ 177-29
 news /nuːz/ 209-12
 newspaper /'nuːz,peɪpər/ 55-17
 newsstand /'nuːz,stænd/ 59-25
 New Year /nu jɪr/ 228-1
 next-day mall /'nekst-deɪ meɪl/ 52-19
 next to /'nekst tə/ 13-11
 nickel /'nɪkəl/ 8-2
 niece /nis/ 27-19
 Nigerian /naɪ'ʤɪriən/ 44-20
 night /naɪt/ 5
 nightgown /'naɪt,ɡaʊn/ 107-14
 nightshirt /'naɪtʃɜːt/ 107-12
 night table /naɪt 'teɪbəl/ 74-10
 nine /naɪn/ 2
 911 /naɪn wʌn wʌn/ 16-5
 nineteen /,naɪn'tɪn/ 2
 nineteenth /,naɪn'tɪnθ/ 3
 ninety /'naɪntɪ/ 2
 ninth /naɪnθ/ 3
 nipple /'nɪpəl/ 57-1
 noisy /'nɔɪzi/ 15-35
 no left turn /nəʊ left tɜːn/ 118-6
 nonfiction section /,nɒn'fɪkʃən 'seksjən/ 55-8
 noon /nuːn/ 5
 north /nɔːθ/ 130-19
 North America /nɔːθ ə'merɪkə/ 174-8
 Northern Canada /'nɔːðərn 'kænədə/ 172-1
 Northern Hemisphere /'nɔːðərn 'hɛmɪs'fɪr/ 174-6
 North Pole /nɔːθ pəʊl/ 174-1
 nose /nəʊz/ 133-37
 bloody... /'blʌdi/ 135-29
 note /'nəʊt/
 absence... /'æbsəns/ 23-27
 notebook /'nəʊtbʊk/ 19-27
 notebook (computer) /'nəʊtbʊk (kəm'pyutər)/ 25-23
 no U-turn /nəʊ 'juː,tɜːn/ 118-11
 novel /'nɒvəl/ 55-20
 November /nəʊ'vembər/ 7-26
 nuclear energy /'njuːklɪər 'enərʤi/ 171-28
 number /'nʌmbər/
 dial a... /'daɪəl ə/ 17-25
 numbers /'nʌmbəz/ 1-2
 nurse /nɜːs/ 29-2
 nurse /nɜːs/ 138-2, 148-19
 school... /skuːl/ 23-8
 nursery /'nɜːsəri/ 216-4
 nurses' station /'nɜːsɪz 'steɪʃən/ 138-1
 nut /nʌt/ 163-23
 wing... /wɪŋ/ 163-24
 nuts /nʌts/ 82-83
 nylon /'naɪ,lɒn/ 113-10
 nylons /'naɪ,lɒnz/ 107-5
 oak (tree) /oʊk (tri)/ 179-5
 oasis /oʊ'eɪsɪs/ 181-15
 obey /oʊ'beɪ/ 201-15
 oboe /'əʊboʊ/ 207-13
 observatory /əb'zɜːrvətɔːri/ 176-8
 obstetrician /,əbstə'trɪʃən/ 141-10
 ocean /'oʊʃən/ 169-24, 211-5
 October /ək'təʊbər/ 7-25
 octopus /'ɒktəpəs/ 189-17
 off /ɔːf/ 13-7
 offer /'ɔːfər/ 102-20
 offer /'ɔːfər/
 make an... /meɪk ən/ 65-19
 office /'ɔːfɪs/ 154-155
 office assistant /ɔːfɪs ə'sɪstənt/ 155-19
 office building /'ɔːfɪs 'bɪldɪŋ/ 47-15
 office manager /'ɔːfɪs 'mænɪdʒər/ 155-6
 oil /ɔɪl/ 171-23
 check the... /tʃek ðə/ 123-16
 oil gauge /ɔɪl ɡeɪʤ/ 121-13
 oil spill /ɔɪl spɪl/ 171-15
 old /əʊld/ 14-21, 15-32
 olive green /'ɒlɪv ɡrɪn/ 10-6
 olive oil /'ɒlɪv ɔɪl/
 bottle of... /'bɒtl əv/ 97-7
 measure... /'meʒər/ 92-1
 olives /'ɒlɪvz/ 83-23
 on /ən/ 13-3
 one /wʌn/ 2

one-bedroom apartment /wʌn-'bed,rʊm ə'pɑ:tmənt/ 67-13
 one cent /wʌn sɛnt/ 8-1
 one dollar /wʌn 'dɒlə/ 8-6
 one-dollar bill /wʌn-'dɒlə bɪl/ 8-6
 one-half /wʌn-hæf/ 3
 one hundred /wʌn 'hʌndrɪd/ 2
 one hundred-dollar bill /'wʌn 'hʌndrɪd-'dɒlə bɪl/ 8-11
 one hundred dollars /'wʌn 'hʌndrɪd 'dɒləz/ 8-11
 one hundred thousand /'wʌn 'hʌndrɪd 'θaʊzənd/ 2
 one million /wʌn 'mɪljən/ 2
 one-quarter /wʌn-'kwɔ:tər/ 3
 one thousand /wʌn 'θaʊzənd/ 2
 one way /wʌn weɪ/ 118-1
 onion /'ɒnjən/ 84-15
 slice... /sleɪs/ 93-18
 online /,ɒn'laɪn/
 be... /bi/ 24-30
 online catalog /,ɒn'laɪn 'kætəlɒg/ 55-6
 Ontario /ɒn'terɪoʊ/ 172-4
 on the left of /ɒn ðə left əv/ 13-8
 on the right of /ɒn ðə raɪt əv/ 13-9
 on top of /ɒn tɒp əv/ 13-1
open /'oʊpən/
 ...a present /ə 'prezənt/ 229-32
 ...mall /meɪl/ 150-5
 ...your book /jə bʊk/ 20-10
 open /'oʊpən/ 15-37
opens /'oʊpənz/ 198-11
 opera /'ɒprə/ 205-25
operate /'ɒpə,reɪt/ 165-15
 operating room /'ɒpə,reɪtɪŋ rʊm/ 138-5
 operating table /'ɒpə,reɪtɪŋ 'teɪbəl/ 138-8
 operation /,ɒpə'reɪʃən/ 139-11
 operator /'ɒpə'reɪtər/ 16-17
 opossum /ə'pɒsəm/ 190-7
 opposites /'ɒpəzɪtɪz/ 14-15
 optometrist /ɒp'tɒmətɪst/ 141-23
 orange /'ɒrɪndʒ/ 10-19, 83-3
 orange juice /'ɒrɪndʒ dʒʊs/ 88-27
 carton of... /'kɑ:tɪn əv/ 97-10
 orangutan /ə'ræŋgə,tæŋ/ 182-13
 orbit /'ɔ:brɪt/ 176-6
 orca /'ɔ:kə/ 189-7
 orchard /'ɔ:ʃə:d/ 152-1
 orchestra /'ɔ:kəstrə/ 204-8
 orchid /'ɔ:kɪd/ 182-11
order /'ɔ:dər/ 102-10
 ...room service /rʊm 'sɜ:vɪs/ 159-26
 order /'ɔ:dər/
 take an... /teɪk ən/ 102-11
 orderly /'ɔ:dərli/ 139-22
 organ /'ɔ:gən/ 207-27
 orthopedist /,ɔ:θə'pɪdɪst/ 141-17
 ostrich /'ɒstrɪʃ/ 185-14
 otter /'ɒtər/ 187-7
 ottoman /'ɒtəmən/ 72-13
 ounce /aʊns/ 96, 97-3
 out /aʊt/
 power ls... /'paʊər ɪz/ 77-1
 outdoor sports and fitness /'aʊt,dɔ: spɔ:ts ənd 'fɪtnɪs/ 220-221
 outlet /'aʊt,let/ 72-32
 outline /'aʊt,laɪn/
 write an... /raɪt ən/ 196-21
 out of /aʊt əv/ 130-5
 outside (of) /,aʊt'saɪd (əv)/ 13-6
 oval /'oʊvəl/ 193-17
 oven /'ɒvən/ 70-8
 microwave... /'maɪkrə,weɪv/ 70-1
 over /'oʊvər/ 13-10, 130-14
 overalls /'oʊvər,ɔ:lz/ 104-12

overdose /'oʊvər,dəʊs/ 136-11
 overhead compartment /'oʊvər,hed kəm'pɑ:tmənt/ 125-24
 overhead light /'oʊvər,hed laɪt/
 turn on the... /tɜ:n ən ðə/ 126-15
 overhead projector /'oʊvər,hed prɒdʒektər/ 19-16
 overnight mail /,oʊvər'nait meɪl/ 52-19
 over-the-counter medication /'oʊvər-ðə-'kaʊntər ,medɪ'keɪʃən/
 142-6
 owl /aʊl/ 181-2
 oysters /'ɔɪstəz/ 87-15
 pacifier /'pæsə,faɪər/ 57-25
pack /pæk/ 64-9, 123-1
 package /'pækɪdʒ/ 52-17
 packer /'pækər/ 156-7
 pad /pæd/ 155-31
 paddle /pædl/ 213-9
 padlock /'pæd,lɒk/ 163-34
 pail /peɪl/ 80-16, 211-28
 pain /peɪn/
 be in... /bi ɪn/ 136-1
paint /peɪnt/ 165-3, 203-25
 paint /peɪnt/ 163-14, 203-10
 paintbrush /'peɪnt brʌʃ/ 163-10, 203-8
 painter /'peɪntər/ 203-9
 house... /haʊs/ 148-14
 painting /'peɪntɪŋ/ 203-7
 paint roller /'peɪnt rʊlər/ 163-16
 paint supplies /'peɪnt sə'plaɪz/ 162
 paint tray /'peɪnt treɪ/ 163-15
 pair of scissors /peər əv 'sɪzəz/ 117-23
 paisley /'peɪzli/ 113-17
 pajamas /pə'dʒɑ:məz/ 107-17
 palace /'pælɪs/ 63-14
 palette /'pæleɪt/ 203-6
 palm tree /pɑ:m tri/ 181-7
 pan /pæn/
 frying... /'fraɪɪŋ/ 94-3
 pan pipes /pæn paɪps/ 207-16
 panther /'pænθər/ 182-17
 panties /'pæntɪz/ 107-20
 pants /'pænts/ 104-22
 baggy... /'bægi/ 111-12
 loose... /lu:s/ 111-12
 pantyhose /'pæntɪ,həʊz/ 107-5
 papaya /pə'paɪə/ 83-18
 paper /'peɪpər/ 196-5
 hand in your... /hænd ɪn jər/ 20-2
 *paperback (book) /'peɪpər,bæk (bʊk)/ 55-14
 paper bag /'peɪpər bæɡ/ 99-14
 paper clip /'peɪpər klɪp/ 155-29
 paper products /'peɪpər 'prɒdæktɪz/ 99-8
 papers /'peɪpəz/
 collect the... /kə'lekt ðə/ 20-3
 exchange... /ɪks'tʃeɪndʒ/ 20-5
 hand out... /hænd aʊt/ 21-18
 paper shredder /'peɪpər ʃredər/ 155-16
 paper towels /'peɪpər 'taʊəlz/ 80-7
 parade /pə'reɪd/ 228-3
 paragraph /'pærə,græf/ 196-4
 parakeet /'pærə,kɪt/ 182-1
 parallel lines /'pærə,leɪ laɪnz/ 193-12
 paramedic /,pærə'medɪk/ 139-26
 parent /'perənt/ 57-8
 parentheses /pə'renθəsɪz/ 196-15
 parents /'perənts/ 27-25
park /pɑ:k/ 123-25
 park /pɑ:k/ 47-28
 park bench /pɑ:k bɛnʃ/ 214-18
 parking /'pɑ:kɪŋ/
 valet... /və'leɪ/ 159-23

parking garage /'pɑ:kɪŋ ɡə'rɑ:ʒ/ 47-21
 parking meter /'pɑ:kɪŋ 'mɪtə/ 58-20
 parking space /'pɑ:kɪŋ speɪs/ 67-8
 parrot /'pærət/ 182-5
 particle mask /'pɑ:tɪkəl mæsk/ 157-26
 parts /pɑ:ts/ 157-13
 parts of a car /pɑ:ts əv ə kɑ: / 120-121
 parts of a fish /pɑ:ts əv ə fɪʃ/ 188
pass /pæs/
 ...a test /ə test/ 19-35
 ...a truck /ə trʌk/ 123-13
pass away /pæs ə'wei/ 31-24
 passbook /'pæs,bʊk/
 savings account... /'seɪvɪŋz ə'kaʊnt/ 51-14
 passenger /'pæsəndʒə/ 124-6, 128-6
 passport /'pæs,pɔ:t/ 43-22
 password /'pæs,wɜ:d/
 enter your... /'entə yə/ 24-31
 past /pæst/ 130-2
 pastries /'peɪstrɪz/
 tray of... /treɪ əv/ 97-11
 path /pæθ/ 214-27
 patient /'peɪʃənt/ 139-18
 examine the... /ɪg'zæməŋ ðə/ 137-22
 patio /'pæti,ou/ 69-22
 patterns /'pætərnz/ 112-113
pause /pɔ:z/ 227-29
 paw /pɔ:/ 185-27
pay /peɪ/
 ...a security deposit /ə sə'kyʊərəti dɪ'pɑ:sɪt/ 64-7
 ...a toll /ə təʊl/ 123-23
 ...taxes /'tæksɪz/ 201-16
 ...the bills /ðə bɪlz/ 79-6
 ...the check /ðə tʃek/ 102-24
 ...the rent /ðə rent/ 64-14
 payment /'peɪmənt/
 make the... /meɪk ðə/ 65-26
 pay phone /peɪ fəʊn/ 16-1
 PDA /'pi'di'eɪ/ 25-16
 peach /pi:tʃ/ 83-19
 peacock /'pi,kæk/ 182-8
 peak /pik/ 169-1
 peanuts /'pi,næts/ 83-33
 pear /peə/ 83-1
 peas /pi:z/ 85-30
 pebble /'pebəl/ 181-17
 pecans /pɪ'kænz/ 83-30
 pedestrian /pə'destriən/ 58-17
 pedestrian crossing /pə'destriən 'krɒsɪŋ/ 118-9
 pediatrician /,pɪdiə'triʃən/ 141-7
peel /pi:l/ 93-22
 peephole /'pi:p,həʊl/ 67-26
 pen /pen/ 19-19
 pencil /'pensəl/ 19-20
 pencil sharpener /'pensəl 'ʃɑ:pənə/ /
 electric... /ɪ'lektɪk/ 155-21
 penguin /'penɡwɪn/ 187-13
 peninsula /pə'nɪnsələ/ 169-17
 penny /'peni/ 8-1
 PEOPLE /'pi:pəl/ 32-45
 pepper shaker /'pepə 'ʃeɪkə/ 101-13
 percent /pə'sent/ 193-4
 percussion /pə'rʌʃən/ 207
perform /pə'fɔ:m/ 150-10
 performing arts /pə'fɔ:mɪŋ ɑ:ts/ 204-205
 perfume /'pɜ:fju:m/ 144-21
 period /'piəriəd/ 196-10
 periodical section /,piəri'adɪkəl 'sekʃən/ 55-1
 periodic table /,piəri'adɪk 'teɪbəl/ 194-15
 periods of time /'piəriədz əv taɪm/ 4

permission slip /pə'r'mɪʃən slɪp/ 23-26
 perpendicular lines /,pɜ:pən'dɪkylələr laɪnz/ 193-11
 personal CD player /'pɜ:snəl 'si:di 'pleɪə/ 226-10
 personal check /'pɜ:snəl tʃek/ 9-25
 Peruvian /pə'ru:vɪən/ 44-6
 pesticide poisoning /'pestə'saɪd 'pɔɪzənɪŋ/ 171-16
 petal /'petl/ 179-16
 pet food /pet fud/ 99-10
 petri dish /'pɪtri dɪʃ/ 194-29
 petroleum /pə'trəʊliəm/ 171-23
 pet store /pet stɔ:/ 48-21
 pharmacist /'fɑ:məsɪst/ 142-5
 pharmacy /'fɑ:məsi/ 48-26, 142-143
 phone /fəʊn/
 answer the... /'ænsə ðə/ 17-27
 hang up the... /hæŋ ʌp ðə/ 17-29
 pick up the... /pɪk ʌp ðə/ 17-24
 phone book /fəʊn bʊk/ 16-8
 phone card /fəʊn kɑ:d/ 16-3
 phone jack /fəʊn tʃæk/ 16-14
 phone number /fəʊn 'nʌmbə/ 16-23
 photocopier /'fəʊtə,kəpiə/ 155-4
 photocopy /'fəʊtə,kəpi/ 155-5
photograph /'fəʊtə,græf/ 203-26
 photograph /'fəʊtə,græf/ 203-22
 take a... /teɪk ə/ 203-26
 photographer /fə'tægrəfə/ 148-12, 203-23
 photo ID /'fəʊtəʊ 'aɪ'di/ 124-3
 photo kiosk /'fəʊtəʊ 'ki:sk/ 48-29
 physical (exam) /'fɪzɪkəl (ɪg'zæm)/ 141-18
 physical therapist /'fɪzɪkəl 'θerəpɪst/ 148-6
 physicist /'fɪzɪsɪst/ 194-6
 physics /'fɪzɪks/ 194-5
 piano /pi'ænəʊ/ 207-26
pick /pɪk/ 153-31
 pickles /'pɪkəlz/ 88-10
pick up /pɪk ʌp/ 29-10, 29-19
 ...the phone /ðə fəʊn/ 17-24
 pickup truck /'pɪk,ʌp trʌk/ 118-15
 picnic /'pɪknɪk/ 214-11
 picnic basket /'pɪknɪk 'bæskɪt/ 214-12
 picnic table /'pɪknɪk 'teɪbəl/ 214-13
 picture book /'pɪktʃə bʊk/ 55-25
 piece /pi:s/
 ...of cake /əv keɪk/ 97-15
 pie pan /paɪ pæn/ 95-29
 pier /pɪə/ 211-2
 pierced ears /pɪəsd ɪəz/ 33-20
 pig /pɪg/ 152-25
 pigeon /'pɪdʒən/ 214-29
 pigtales /'pɪg,telz/ 33-26
 pile /paɪl/
 ...of tomatoes /əv tə'metəʊz/ 97-28
 pill /pɪl/ 142-3
 take a... /teɪk ə/ 137-27
 pillow /'pɪləʊ/ 74-12
 ask for a... /æsk fɔ: ə/ 126-14
 pillowcase /'pɪləʊ,keɪs/ 74-11
 pilot /'paɪlət/ 125-15, 148-23
 PIN /pɪn/
 enter... /'entə/ 51-25
 pin /pɪn/ 109-12, 117-21
 pincushion /pɪn 'kʊʃən/ 117-22
 pine (tree) /paɪn (tri)/ 179-1
 pineapple /'paɪ,næpəl/ 83-7
 pinecone /paɪn kəʊn/ 179-9
 ping-pong /'pɪŋ-pʌŋ/ 218-8
 ping-pong paddle /'pɪŋ-pʌŋ pædl/ 218-9
 ping-pong table /'pɪŋ-pʌŋ 'teɪbəl/ 218-10
 pink /pɪŋk/ 10-4

- pint /paɪnt/ 96, 97-1
 pinto beans /pɪntoʊ bɪnz/ 84-9
 pipe /paɪp/ 161-26
 cut a... /kʌt ə/ 165-21
 pipe fittings /paɪp 'fɪtɪŋz/ 160-24
 pipes /paɪps/
 ...are frozen /ər 'frouzən/ 77-8
 pipe wrench /paɪp rɛntʃ/ 161-25
 pistachios /pɪ'stæʃi, oʊz/ 83-32
 pitcher /'pɪtʃər/ 97-14
 pizza /'pɪtsə/ 90-1
 placemat /'pleɪsmæt/ 70-26
 place of birth /pleɪs əv bərθ/ 43-7
 places around town /'pleɪsɪz ə'raʊnd taʊn/ 46-47
 places to visit /'pleɪsɪz tə 'vɪzɪt/ 216-217
 plaid /plæd/ 113-19
 plains /pleɪnz/ 169-26
 plan /plæn/ 150-16
 plane /pleɪn/
 ...wood /wʊd/ 165-23
 plane /pleɪn/ 125
 board the... /bɔːrd ðə/ 126-8
 get off the... /ɡet ɒf ðə/ 126-23
 planetarium /,plænə'terɪəm/ 216-3
 planets /'plænɪts/ 176
 plant /plænt/ 153-29
 plaster /'plæstər/ 165-2
 plastic bag /'plæstɪk bæɡ/ 99-20
 plate /pleɪt/ 70-23, 101-23
 plateau /plæ'toʊ/ 169-12
 platform /'plæt, fɔːm/ 128-19
 play /pleɪ/ 227-26
 play /pleɪ/ 205-17
 player /'pleɪər/
 basketball... /'bæskɪt bɔːl/ 218-6
 hockey... /'hɑːki/ 223-22
 playground /'pleɪ,ɡraʊnd/ 214-4
 playpen /'pleɪ,pɛn/ 57-4
 play with /pleɪ wɪð/ 29-9
 pleated /'plɪtəd/
 ...skirt /skɜːrt/ 111-19
 pliers /'plɪərz/ 160-15
 plow /pləʊ/ 152-5
 plug /plʌɡ/ 226-6
 plum /plʌm/ 83-15
 plumber /'plʌməː/ 77-15, 148-15
 plumbing /'plʌmɪŋ/ 161
 plunger /'plʌndʒər/ 75-23
 plus /plʌs/ 193-1
 Pluto /'pluːtoʊ/ 176-20
 plywood /'plɑɪ,wʊd/ 163-28
 P.O. Box /pi'ou baks/ 52-13
 pocket /'pɒkɪt/ 117-13
 pocket knife /'pɒkɪt naɪf/ 213-21
 poison /'pɔɪzən/
 swallow... /'swaləʊ/ 136-10
 poisoning /'pɔɪzənɪŋ/
 pesticide... /'pestə,sɑɪd/ 171-16
 poisonous materials /'pɔɪzənəs mə'tɪrɪəlz/ 156-34
 polar bear /'pəʊlər beɪ/ 187-8
 polar lands /'pəʊlər lændz/ 186-187
 police car /pə'lis kɑː/ 118-26
 police officer /pə'lis 'ɒfɪsər/ 61-20, 148-11
 police station /pə'lis 'steɪʃən/ 47-10
 polish /'pɒlɪʃ/ 79-9
 political candidate /pə'ltɪkəl 'kændɪdeɪt/ 200-1
 polka dot /'pɒlkə dɒt/ 113-15
 pollution /pə'ljuːʃən/ 170-171
 air... /eɪ/ 171-13
 water... /'wɔːtər/ 171-19
 polo /'pəʊləʊ/
 ...shirt /ʃɑːrt/ 111-7
 pomegranate /'pɒmə,ɡrænɪt/ 83-4
 poncho /'pɒntʃoʊ/ 104-11
 pond /pɒnd/ 214-19
 ponytail /'pəʊni,tel/ 33-24
 pool /puːl/
 swimming... /'swɪmɪŋ/ 159-21, 218-34
 pool hall /puːl hɔːl/ 216-7
 poor /pʊər/ 15-28
 pop /pɒp/ 209-22
 popcorn /'pɒp,kɔːrn/ 99-28
 poppies /'pɒpɪz/ 179-32
 porch /pɔːtʃ/ 69-14
 porcupine /'pɔːkjuːpaɪn/ 190-11
 pork /pɔːrk/ 86
 pork chops /pɔːrk tʃɒps/ 87-3
 pork roast /pɔːrk rəʊst/ 87-7
 portrait /'pɔːtrɪt/ 203-3
 postal clerk /'pəʊstəl klɜːk/ 52-20
 postal scale /'pəʊstəl skeɪl/ 52-15
 postcard /'pəʊst,kɑːrd/ 52-16
 poster /'pəʊstər/ 19-23
 postmark /'pəʊst,mɑːk/ 52-18
 post office /pəʊst 'ɒfɪs/ 47-14, 52-53
 post office box /pəʊst 'ɒfɪs bɒks/ 52-13
 pot /pɒt/ 94-5
 ...of coffee /əv 'kɒfi/ 97-12
 potato /pə'teɪtoʊ/ 84-26
 potato chips /pə'teɪtoʊ tʃɪps/ 99-27
 potatoes /pə'teɪtoʊz/
 bag of... /bæg əv/ 97-22
 boil... /bɔɪl/ 92-17
 potholder /'pɒt,həʊldər/ 70-9
 potter /'pɒtər/ 203-19
 potter's wheel /'pɒtərz wɪl/ 203-20
 pottery /'pɒtəri/ 203-18
 potty chair /'pɒti tʃeə/ 57-20
 poultry /'pəʊltrɪ/ 86-87, 99-2
 pound /paʊnd/ 96, 97-19
 pour /pɔːr/
 ...concrete /kən'kriːt/ 165-7
 ...water /'wɔːtər/ 102-2
 powder /'paʊdər/
 baby... /'beɪbi/ 57-22
 power /'paʊər/
 hydroelectric... /,haɪdrəʊ'lektrɪk/ 171-29
 ...is out /ɪz aʊt/ 77-1
 power sander /'paʊər 'sændər/ 161-32
 power strip /'paʊər ,striːp/ 25-12
 power tools /'paʊər tuːlz/ 161
 Prairie Provinces /'preəri 'prɑːvɪnsəz/ 172-3
 praise /preɪz/ 29-17
 pregnant /'pregnənt/
 be... /bi/ 31-14
 pregnant woman /'pregnənt 'wʊmən/ 141-11
 preschooler /'priːskulər/ 56-34
 prescription /'priːskrɪpʃən/ 142-15
 prescription medicine /'priːskrɪpʃən 'medɪsən/ 142-4
 present /'prezənt/ 228-11
 open a... /'əʊpən ə/ 229-32
 wrap a... /ræp ə/ 229-29
 president /'prezədənt/ 200-11
 press /pres/ 115-23
 pretzels /'pretsəlz/ 99-26
 price /praɪs/ 9-18
 negotiate the... /nɪ'ɡəʊsɪ,eɪt ðə/ 65-20
 price tag /praɪs tæg/ 9-16
 primary colors /'praɪ,merɪ 'kɒlərz/ 10
 principal /'prɪnsəpəl/ 23-16

- print (out) /print (aʊt)/ 24-35**
 print /print/ 113-14
 printer /'prɪntər/ 25-15
 prism /'prɪzəm/ 194-7
 prison /'prɪzən/ 61-26
 prisoner /'prɪzənər/ 61-27
produce /prə'dʌs/ 198-2
 produce /'prɒdʌs/ 99-1
 program /'prɒɡræm/ 205-23
 computer... /kəm'pyʊtər/ 25-25
 projector /prə'dʒektər/ 25-13
 overhead... /,oʊvər'hed/ 19-16
protect /prə'tekt/ 29-14
protest /prə'test/ 201-18
 proud /praʊd/ 38-1
 psychologist /saɪ'kɒlədʒɪst/ 141-5
 public transportation /'pʌblɪk ˌtrænspɔrt'eɪʃən/ 128-129
 puck /pʌk/
 hockey... /'hɑki/ 223-24
pull /pʊl/ 37-27, 165-6
pull over /pʊl 'oʊvər/ 123-20
 pullover /'pʊləʊvər/ 104-20
 pump /pʌmp/ 109-18
 pumpkin pie /'pʌmpkɪn paɪ/ 229-18
 punching bag /'pʌŋtɪŋ bæɡ/ 218-20
 punctuation /ˌpʌŋktʃu'eɪʃən/ 196-9
 puppet show /'pʌpɪt ʃəʊ/ 214-10
puree /pyu'rei/ 93-25
 purple /'pɜ:pəl/ 10-14
 purse /pɜ:s/ 109-2
push /pʌʃ/ 37-25, 165-20
 push-up /'pʌʃ-ʌp/ 218-12
put /pʊt/
 ...air in the tires /ər ɪn ðə taɪrz/ 123-18
 ...a stamp on /ə stæmp ən/ 53-23
put away /pʊt ə'weɪ/ 79-24
put down /pʊt daʊn/ 126-18
put on /pʊt ən/ 114-8
 ...makeup /'meɪkʌp/ 34-7
 ...your headphones /jər 'hedfəʊnz/ 126-16
put out /pʊt aʊt/ 79-19
put up /pʊt ʌp/ 165-1
 puzzle /'pʌzəl/ 224-16
 pyramid /'pɪrəˌmɪd/ 193-21
 pyramids /'pɪrəˌmɪdz/
 build... /bɪld/ 198-3
 quart /kwɔ:t/ 96, 97-18
 quarter /'kwɔ:tər/ 3, 8-4
 quarter after six /'kwɔ:tər əftər sɪks/ 5
 quarter moon /'kwɔ:tər mʌn/ 177-31
 quarter of seven /'kwɔ:tər əv 'sevən/ 5
 quarter past six /'kwɔ:tər pæst sɪks/ 5
 quarter to seven /'kwɔ:tər tə 'sevən/ 5
 Quebec /kwə'bek/ 172-5
 queen /kwɪn/ 224-4
 question mark /'kwɛstʃən mɑ:k/ 196-12
 questions /'kwɛstʃənz/
 ask... /æsk/ 64-5
 quiet /'kwaɪt/ 15-36
 quotation marks /'kwəʊ'teɪʃən mɑ:ks/ 196-16
 rabbit /'ræbɪt/ 152-18, 190-28
 raccoon /ræ'kʊn/ 190-19
 racket /'rækɪt/
 tennis... /'tenɪs/ 220-2
 radiation /ˌreɪdɪ'eɪʃən/ 171-17
 radiator /'reɪdɪ,eɪtər/ 121-35
 radio /'reɪdɪəʊ/ 121-17
 radioactive materials /ˌreɪdɪəʊ'æktɪv mə'tɪrɪəlz/ 156-35
 radish /'rædɪʃ/ 85-31
 radius /'reɪdɪəs/ 193-14
 raft /ræft/ 213-10
 rag /ræg/ 80-17
 railroad crossing /'reɪlˌroʊd 'krɒsɪŋ/ 118-7
 rain /reɪn/ 166-20
 acid... /'æsɪd/ 171-14
 rainbow /'reɪnbəʊ/ 166-11
 raincoat /'reɪn,kəʊt/ 104-10
 raindrop /'reɪn,drɒp/ 166-23
 rain forest /reɪn 'fɔ:ɪst/ 182-183
 raining /'reɪnɪŋ/ 167-30
raise /reɪz/
 ...a family /ə 'fæməli/ 31-16
 ...your hand /jər hænd/ 20-1
 raising a child /'reɪzɪŋ ə ʃaɪld/ 28-29
 raisins /'reɪzənz/ 83-27
rake /reɪk/ 79-20
 rake /reɪk/ 69-17
 ranch /ræntʃ/ 63-16
 rash /ræʃ/ 135-26
 raspberries /'ræz,bɛrɪz/ 83-26
 rat /ræt/ 181-13
 rats /ræts/ 76-25
 rattle /'rætl/ 57-10
 razor /'reɪzər/ 144-18
 electric... /ɪ'lektrɪk/ 144-19
 R&B /ər ən bi/ 209-26
reach /ri:tʃ/ 198-18
read /ri:d/ 20-7, 29-20, 55-28
 ...blueprints /'blu:prɪnts/ 165-17
 reading room /'ri:dɪŋ rʊm/ 55-4
 reality show /ri'æləti ʃəʊ/ 209-21
 realtor /'ri:əltər/ 148-20
 call a... /kəl ə/ 65-16
 rearview mirror /'ri:vyu 'mɪrər/ 121-11
 receipt /ri'si:t/ 9-14
 receiver /ri'si:vər/ 16-2
 receptionist /rə'sepʃənɪst/ 141-16, 148-5
 recipe /'resəpi/ 92, 93
 record /'rekərd/ 226-8
 RECREATION /ˌrekri'eɪʃən/ 210-229
 rectangle /'rek,tæŋɡəl/ 193-18
 recycling bin /ri'saɪklɪŋ bɪn/ 80-25
 red /red/ 10-1
 red hair /red heər/ 33-1
 referee /ˌrefə'reɪ/ 218-4
 reference desk /'refərəns desk/ 55-5
refill /ri'fɪl/ 102-14
 refrigerator /rɪ'frɪdʒə'reɪtər/ 70-20
 regions of Canada /'rɪdʒənz əv 'kænədə/ 172
 regions of the United States /'rɪdʒənz əv ðə ju'naitɪd steɪts/ 172
 registration desk /ˌredʒɪ'streɪʃən desk/ 159-12
 registration form /ˌredʒɪ'streɪʃən fɔ:m/ 43
 regular price /'regjələr praɪs/ 9-22
 reindeer /'reɪn,dɪr/ 187-3
 remarried /ri'mæriəd/ 27-30
 remote control /rə'məʊt kən'trəʊl/ 226-23
remove /rə'mu:v/ 51-28
rent /rent/
 ...an apartment /ən ə'pɑ:tmənt/ 31-7
 rent /rent/
 pay the... /peɪ ðə/ 64-14
 renting an apartment /'rentɪŋ ən ə'pɑ:tmənt/ 64
repair /rə'peər/ 115-21, 150-15
 report card /rə'pɔ:t kɑ:d/ 23-24
 reporter /rə'pɔ:tər/ 148-1
 reservation /ˌrezə'veɪʃən/
 make a... /meɪk ə/ 102-1, 159-24
 Resident Alien card /'rezɪdənt eɪlɪən kɑ:d/ 43-17
 respirator /'respə'reɪtər/ 157-22
rest /rest/ 137-26

restaurant /'restərənt/ 100-101
 rest mat /rest mæt/ 57-5
 restroom /'restrum/ 23-10
 resume /'rezə,meɪ/ 155-17
retire /rə'taɪr/ 31-22
 retirement /rə'taɪrmənt/ 229-28
 retirement home /rə'taɪrmənt hoʊm/ 63-17
return /rɪ'tɜrn/ 55-29
 return address /rɪ'tɜrn ə'dres/ 52-4
 revolving door /rɪ'vɒlvɪŋ dɔːr/ 67-24, 159-14
rewind /ri'waɪnd/ 227-28
 rhinoceros /raɪ'nasərəs/ 185-8
 ribs /rɪbz/ 87-9
 rice /raɪs/ 91-19
 rich /rɪʃ/ 15-27
ride /raɪd/ 37-26
 right /raɪt/ 130-16
 ring /rɪŋ/ 109-7
 river /'rɪvər/ 169-21
 riverbank /'rɪvərbæŋk/ 169-20
 road trip /rəʊd trɪp/ 122-123
roast /rəʊst/ 92-15
 roast beef /rəʊst bɪf/ 87-11
 robe /rəʊb/ 107-13
 robin /'rəʊbɪn/ 190-1
 robot /'rəʊbət/ 156-5
rock /rɒk/ 29-3
 rock /rɒk/ 181-11, 209-24
 rock climber /rɒk 'klaɪmər/ 213-2
 rock concert /rɒk 'kɒnsərt/ 205-10
 rocket /'rɒkət/ 176-4
 rocking chair /'rɒkɪŋ tʃeə/ 72-31
 Rocky Mountain States /rɒki 'maʊntn steɪts/ 172-8
 rodeo /'rəʊdi,əʊ/ 216-23
 roller /'rəʊlər/
 paint... /peɪnt/ 163-16
 roller coaster /'rəʊlər 'kəʊstər/ 214-16
 rollers /'rəʊlərz/ 144-9
 rolling pin /'rəʊlɪŋ pɪn/ 95-22
 roll of film /rəʊl əv fɪlm/ 226-1
roll up /rəʊl ʌp/ 114-12
 romance /rəʊ'mæns/ 208-5
 roof /rʊf/ 69-4
 ...leaks /liks/ 77-3
 roofer /'rʊfər/ 77-16
 room /rʊm/
 double... /'dʌbəl/ 159-17
 meeting... /'mi:tɪŋ/ 159-6
 single... /'sɪŋɡəl/ 159-18
 roommate /'rʊm,meɪt/ 67-11
 room service /rʊm 'sɜrvɪs/ 159-3
 order... /'ɔːdə/ 159-26
 rooster /'rəʊstər/ 152-20
 roots /rʊts/ 179-12
 rope /'rəʊp/ 163-9, 213-17
 pull a... /pʊl ə/ 165-6
 roses /'rəʊzəz/ 179-28
 rouge /rʊʒ/ 144-28
 router /'rəʊtər/ 161-27
 rowboat /'rəʊ,bəʊt/ 213-7
 rubber band /'rʌbər bænd/ 155-24
 rubber gloves /'rʌbər glʌvz/ 80-18
 rug /rʌg/ 74-4
 shake out the... /ʃeɪk aʊt ðə/ 79-14
 ruler /'rʊlər/ 160-17
rules /rʊlz/ 198-7
run /rʌn/ 37-11
 runner /'rʌnər/ 220-17
 runway /'rʌn,weɪ/ 125-13
 rural area /'rʊrəl 'eəriə/ 63-23
 Russian /'rʌʃjən/ 44-21
 RV /'ar'vi/ 118-16
 sad /sæd/ 39-21
 safe-deposit box /seɪf-dɪ'pɑːsɪt bɒks/ 51-1
 safety boots /'seɪftɪ bʊts/ 157-28
 safety-deposit box /'seɪftɪ-dɪ'pɑːsɪt bɒks/ 51-1
 safety earmuffs /'seɪftɪ 'ɪr,mʌfs/ 157-29
 safety glasses /'seɪftɪ glæsɪz/ 157-25
 safety goggles /'seɪftɪ 'gɒɡəlz/ 157-23
 safety pin /'seɪftɪ pɪn/ 117-30
 safety vest /'seɪftɪ vest/ 157-27
 safety visor /'seɪftɪ 'vaɪzər/ 157-21
sail /seɪl/ 198-4
 sailboard /'seɪl,bɔːrd/ 211-12
 sailboarder /'seɪl,bɔːrdər/ 211-13
 sailboat /'seɪl,bəʊt/ 211-1
 salad /'sæləd/ 88-18
 salad bar /'sæləd bɑːr/ 101-30
 salad dressing /'sæləd 'dresɪŋ/ 88-19
 salamander /'sælə,mændər/ 190-17
 salami /sə'lɑːmi/ 87-5
 sale /seɪl/ 9-12
 sale price /seɪl praɪs/ 9-23
 salesperson /'seɪlz,pɜːsən/ 148-21
 sales tax /'seɪlz tæks/ 9-19
 salmon /'sælmən/ 87-24
 salsa /'salsə/ 91-27
 saltshaker /'sɒlt,ʃeɪkər/ 101-12
sand /sænd/ 165-25
 sand /sænd/ 211-21
 shovel... /'ʃʌvəl/ 165-19
 sandal /'sændl/ 109-21
 sandbox /'sænd,bɒks/ 214-8
 sand castle /sænd 'kæsl/ 211-25
 sand dune /sænd dʌn/ 181-6
 sander /sændər/
 power... /'paʊər/ 161-32
 sandpaper /'sænd,peɪpər/ 163-12
 sandwich /'sændwɪʃ/ 90-10
 Santa Claus /'sæntə,kloʊz/ 229-20
 sari /'sɑːri/ 104-9
 satellite /'sætɪl,ait/ 176-13
 satellite dish /'sætɪl,ait dɪʃ/ 226-18
 Saturday /'sætər,deɪ/ 6-10
 Saturn /'sætərən/ 176-23
 saucepan /'sɔːs,pæn/ 94-10
 saucer /'sɔːsər/ 101-19
 Saudi Arabian /'səʊdi ə'reɪbiən/ 44-19
 sauna /'səʊnə/ 159-20
 sausages /'sɔːsɪdʒəz/ 87-6
sauté /sə'teɪ/ 93-19
 savings account passbook /'seɪvɪŋz ə'kaʊnt 'pæs,bʊk/ 51-14
saw /sɔː/ 165-10
 saw /sɔː/
 circular... /'sɜːrkjələ/ 161-31
 saxophone /'sæksə'fəʊn/ 207-11
 scale /skeɪl/ 99-7
 postal... /'pəʊstəl/ 52-15
 scales /sketlz/ 189-6
 scallions /'skæljənz/ 85-27
 scallops /'skæləps/ 87-19
scan /skæn/ 24-34
 scanner /skænər/ 25-14
 scar /skɑːr/ 33-7
 scarecrow /'sker,kroʊ/ 152-12
 scared /skerd/ 39-19
 scarf /skɑːf/ 104-18
 schedule /'skedʒul/ 128-22
 student... /'studnt/ 23-25
SCHOOL /skul/ 18-25

- school /skul/ 47-6
 start... /start/ 31-3
 take your child to... /teik yər tʃaɪld tə/ 34-10
 school bus /skul bʌs/ 23-12, 118-12
 school library /skul 'laɪbrəri/ 23-7
 school nurse /skul nɜːs/ 23-8
 SCHOOL SUBJECTS /skul 'sʌbdʒɪkts/ 192-201
 school zone /skul zəʊn/ 118-8
 science /'saɪəns/ 194-195
 science fiction /'saɪəns 'fɪkʃən/ 208-6
 scientist /'saɪəntɪst/ 148-16
 scissors /'sɪzərz/
 pair of... /pɛr əv/ 117-23
 score /skɔːr/ 223-19
 scoreboard /'skɔːrbɔːrd/ 223-18
 scorpion /'skɔːrpiən/ 181-23
 scouring pad /skaʊrɪŋ pæd/ 80-14
scramble /'skræmbəl/ 92-7
 scraper /skreɪpər/ 163-11
 screen /skriːn/ 25-20
 screw /skruː/ 163-22
 screwdriver /'skruːdraɪvər/ 160-18
 scroll bar /skroʊl bɑːr/ 25-10
scrub /skrʌb/ 79-11
 scrub brush /skrʌb brʌʃ/ 80-20
 scuba diver /'skubə 'daɪvər/ 189-13
 sculptor /'skʌlptər/ 203-17
 sculpture /'skʌlptʃər/ 203-16
 sea /si/ 188-189
 sea anemone /si ə'neɪməni/ 189-25
 seafood /'siːfud/ 86-87
 seagull /'siːgʌl/ 189-1
 sea horse /si hɔːrs/ 189-14
 seal /sil/ 187-12
 seam /sim/ 117-25
 seashell /'siːʃel/ 211-22
season /'siːzən/ 92-14
 seasons /'siːzənz/ 7
 seat /sit/ 19-26, 125-27, 205-20
 find your... /faɪnd yər/ 126-9
 seat belt /sit bɛlt/ 121-12, 125-28
 fasten... /'fæsn/ 126-12
 unfasten your... /ʌn'fæsn yər/ 126-22
 sea urchin /si 'ɜːtʃɪn/ 189-22
 seaweed /'siːwiːd/ 189-9
 second /'sekənd/ 3, 4
 second-hand store /'sekənd-hænd stɔːr/ 48-14
 secretary /'sekɪrətəri/ 155-19
 security /sə'kyʊərəti/
 go through... /gəʊ θruː/ 126-5
 security checkpoint /sə'kyʊərəti 'tʃek.pɔɪnt/ 125-10
 security deposit /sə'kyʊərəti dɪ'pɒzɪt/
 pay a... /peɪ ə/ 64-7
 security guard /sə'kyʊərəti gɑːrd/ 51-2, 148-8
 sedan /sə'dæn/ 118-19
see /si/ 64-4
 seed /sid/ 179-24
 seesaw /'siːsə/ 214-7
select /sə'lekt/ 24-32
sell /sɛl/ 150-14
 semi /semi/ 118-25
 semicolon /'semiːkəʊlən/ 196-18
 Senate /'senɪt/ 201
 senator /'senətər/ 200-10
send /send/ 53-24
 senior (citizen) /'sɪniər ('sɪtəzən)/ 31
 sentence /'sentns/ 196-3
 copy the... /'kɒpi ðə/ 20-4
 September /sep'tembər/ 7-24
serve /sɜːv/
 ...a meal /ə mil/ 102-16
 ...in the military /ɪn ðə 'mɪləteri/ 201-19
 ...on a jury /ən ə 'dʒʊri/ 201-17
 server /'sɜːrvər/ 101-4, 101-6, 148-18
 signal the... /'sɪgnəl ðə/ 102-18
 thank the... /θæŋk ðə/ 102-21
set /set/ 102-5
 set /set/ 205-19
 set of knives /set əv naɪvz/ 94-2
 seven /'sevən/ 2
 seventeen /'sevən'tɪn/ 2
 seventeenth /'sevən'tɪnθ/ 3
 seventh /'sevənθ/ 3
 seventy /'sevənti/ 2
 sewing /'souɪŋ/ 117
 sewing machine /'souɪŋ mə'ʃɪn/ 117-20
sew on /'sou ən/ 115-22
 sex /seks/ 43-5
 shade /ʃeɪd/
 window... /'wɪndəʊ/ 74-8
shake hands /ʃeɪk hændz/ 40-4
shake out /ʃeɪk aʊt/ 79-14
 shampoo /ʃæm'puː/ 144-2
 shapes /ʃeɪps/ 193
share /ʃer/
 ...a book /ə buːk/ 21-21
 ...a dessert /ə dɪ'zɜːt/ 102-19
 shark /ʃɑːrk/ 189-12
shave /ʃeɪv/ 34-6
 shaving cream /'ʃeɪvɪŋ kriːm/ 144-16
 shawl /ʃɔːl/ 104-23
 sheep /ʃiːp/ 152-23
 sheet /ʃiːt/ 74-15
 sheets /ʃiːts/
 change the... /tʃeɪndʒ ðə/ 79-2
 shelf /ʃelf/ 70-4
 shellfish /'ʃelɪʃɪʃ/ 87
 shingles /'ʃɪŋɡəlz/ 163-5
 ship /ʃɪp/ 211-6
 shipping clerk /'ʃɪpɪŋ klɜːk/ 157-16
 shirt /ʃɜːt/ 104-2
 button-down... /'bʌtn-daʊn/ 111-6
 long-sleeved... /lɔːŋ-sliːvd/ 111-5
 polo... /'pəʊləʊ/ 111-7
 short-sleeved... /ʃɔːrt-sliːvd/ 111-4
 sleeveless... /'sliːvlɪs/ 111-3
 shish kebab recipe /ʃɪʃ kə'bɑːb 'resəpi/ 92
 shock /ʃɒk/
 be in... /bi ɪn/ 136-4
 get a... /get ə/ 136-14
 shoes /ʃuːz/ 108-109
 shoe store /ʃu stɔːr/ 48-3
 shop /ʃɒp/
 gift... /gɪft/ 159-22
 shoplifting /'ʃɒp,lɪftɪŋ/ 61-11
 shopper /'ʃɒpər/ 9-13, 99-23
 shopping /'ʃɒpɪŋ/ 9
 shopping basket /'ʃɒpɪŋ 'bæskɪt/ 99-24
 shopping cart /'ʃɒpɪŋ kɑːrt/ 99-17
 shops /ʃɒps/ 48-49
 shore /ʃɔːr/ 169-18
 short /ʃɔːrt/ 14-18
 ...skirt /skɜːrt/ 111-20
 short hair /ʃɔːrt heər/ 33-11
 shorts /ʃɔːrts/ 104-8
 short-sleeved /ʃɔːrt-sliːvd/
 ...shirt /ʃɜːt/ 111-4
 shot /ʃɒt/
 give him a... /gɪv hɪm ə/ 137-25
 shoulder /'ʃəʊldər/ 133-21

shoulder-length hair /'ʃouldər-lɛŋkθ her/ 33-12

shovel /'ʃʌvəl/ 165-19

shovel /'ʃʌvəl/ 160-4, 211-29

show /ʃou/ 126-2

shower /'ʃaʊər/ 75-18

take a... /teɪk ə/ 34-4

shower curtain /'ʃaʊər 'kɜrtɪn/ 75-19

shredder /'ʃredər/

paper... /'peɪpər/ 155-16

shrimp /'ʃrɪmp/ 87-20, 189-21

shrub /'ʃrʌb/ 185-16

shut /ʃʌt/ 15-38

shutter /'ʃʌtər/ 69-11

sick /sɪk/ 39-14

side /saɪd/ 193-10

sideburns /'saɪd,bɜrnz/ 33-15

sidewalk /'saɪd,wɔk/ 47-24, 58-16

sift /sɪft/ 93-28

sign /saɪn/

...the lease /ðə liːs/ 64-6

...the loan documents /ðə loun 'dakyəmənts/ 65-24

sign /saɪn/ 58-19

signal /'sɪgnəl/ 102-18

signature /'sɪgnətʃər/ 43-15

signs /saɪnz/ 118

silk /sɪlk/ 113-4

silo /'saɪləʊ/ 152-2

silver /'sɪlvər/ 10-24

silverware /'sɪlvər,wɛr/ 70-27

simmer /'sɪmə/ 93-21

sing /sɪŋ/ 150-11

singer /'sɪŋər/ 205-14

single mother /'sɪŋgəl 'mʌðər/ 27-29

single room /'sɪŋgəl rum/ 159-18

sink /sɪŋk/ 70-15, 75-28

clean the... /kliːn ðə/ 79-10

sister /'sɪstər/ 27-15

sister-in-law /'sɪstər-ɪn-lɔ/ 27-16

sit (down) /sɪt (daʊn)/ 20-15, 37-16

sitar /'sɪtər/ 207-18

sitcom /'sɪt,kəm/ 209-13

sit-up /sɪt-ʌp/ 218-13

six /sɪks/ 2-6

six fifteen /sɪks fɪf'tɪn/ 5

six fifty-five /sɪks 'fɪfti-faɪv/ 5

six forty-five /sɪks 'fɔrti-faɪv/ 5

six o'clock /sɪks ə'klɔk/ 5

six-oh-five /sɪks-ou-faɪv/ 5

six-pack /sɪks-pæk/ 97-26

sixteen /sɪks'tɪn/ 2

sixteenth /sɪks'tɪnθ/ 3

sixth /sɪksθ/ 3

six-thirty /sɪks-'θɜrti/ 5

six thirty-five /sɪks 'θɜrti-faɪv/ 5

six twenty-five /sɪks 'twenti-faɪv/ 5

sixty /'sɪksti/ 2

skateboard /'skeɪt,bɔrd/ 214-21

skateboarder /'skeɪt,bɔrdər/ 214-22

skater /'skeɪtər/ 214-23

skates /'skeɪts/

ice... /aɪs/ 223-25

in-line... /'ɪn-,laɪn/ 214-24

skating rink /'skeɪtɪŋ rɪŋk/ 223-20

sketch /'sketʃ/ 203-14

sketchpad /'sketʃ pæd/ 203-13

ski boots /'ski buːts/ 222-5

skier /'skiər/ 222-13

skiing /'skiɪŋ/

cross country... /krɒs 'kʌntri/ 222-11

downhill... /'daʊn'hɪl/ 222-12

skin /skɪn/ 133-1

ski poles /'ski puːlz/ 222-6

skirt /skɜrt/ 104-15

long... /lɔŋ/ 111-21

pleated... /pliːtɪd/ 111-19

short... /ʃɔrt/ 111-20

straight... /streɪt/ 111-18

tight... /taɪt/ 111-17

skis /skɪz/ 222-4

skunk /skʌŋk/ 190-22

sky /skaɪ/ 166-10

skylight /'skaɪ,lɑɪt/ 69-3

slacks /slæks/ 104-22

sled /sled/ 222-3

sledgehammer /'sledʒ,hæmə/ 160-3

sleep /sliːp/ 34-24

sleepers /sliːpər/

blanket... /'blæŋkɪt/ 107-16

sleeping bag /sliːpɪŋ bæɡ/ 213-25

sleepwear /'sliːp,wɛr/ 106-107

sleeve /sliːv/ 117-16

sleeveless /'sliːvlɪs/

...shirt /'ʃɜrt/ 111-3

slice /slaɪs/ 93-18

slide /slaɪd/ 194-28, 214-5

sling /slɪŋ/ 141-13

slip /slɪp/ 37-8

slip /slɪp/ 107-23

slippers /'slɪpəz/ 107-11

slow /sləʊ/ 15-33

slow down /sləʊ daʊn/ 123-8

small /smɔl/ 14-1

small town /smɔl taʊn/ 63-22

smile /smaɪl/ 40-18

smog /smɒɡ/ 171-13

smoke detector /sməʊk dɪ'tektər/ 72-18

snacks /snæks/ 99

snail /sneɪl/ 182-22

snake /sneɪk/ 181-14

sneaker /'sniːkər/ 109-22

sneeze /sniːz/ 137-17

snorkel /'snɔrkəl/ 211-11

snorkeler /'snɔrkələr/ 211-10

snow /snoʊ/ 166-19

snowboard /'snoʊ,bɔrd/ 223-16

snowboarder /'snoʊ,bɔrdər/ 222-15

snowboarding /'snoʊ,bɔrdɪŋ/ 222-14

snowflake /'snoʊ,flaɪk/ 166-22

snowing /'snoʊɪŋ/ 167-28

snowmobile /snoʊ 'moʊ,bɪl/ 222-1

snowshoes /'snoʊ,ʃuːz/ 222-2

soap /soʊp/ 144-24

bar of... /bɑr ʌv/ 97-8

soap opera /soʊp 'ɒpərə/ 209-16

soccer /'sɒkər/ 220-19

soccer field /'sɒkər fɪld/ 220-21

Social Security card /'soʊʃəl sə'kyʊərəti kɑrd/ 43-8, 43-21

socks /sɒks/ 107-3

soda /'soʊdə/ 88-5

can of... /kæn ʌv/ 97-27

six-pack of... /sɪks-pæk ʌv/ 97-26

sofa /'soʊfə/ 72-8

soft /sɔft/ 14-10

software /'sɔft,wɛr/ 25-25

soil /soɪl/ 152-10

solar energy /'səʊlər 'enərʒi/ 171-27

soldier /'səʊldʒər/ 148-4

solid /'sɒlɪd/ 113-13, 194-10

solids /'sɒlɪdz/ 193

son /sʌn/ 27-21

- sonogram /'sɒnəgræm/ 141-12
sore throat /sɔː θrəʊt/ 135-8
soul /soul/ 209-26
sour cream /saʊr kɪm/ 88-8
South /sauθ/ 172-13
south /sauθ/ 130-21
South America /sauθ ə'merɪkə/ 174-9
Southern Hemisphere /'sʌðərn 'hɛməs'fɪr/ 174-7
South Pole /sauθ pəʊl/ 174-5
Southwest /sauθ'west/ 172-12
soy sauce /'sɔɪ,sɔːs/ 91-24
space /speɪs/ 176-11
space shuttle /speɪs 'ʃʌtl/ 176-17
space station /speɪs 'steɪʃən/ 176-1
spade /speɪd/ 224-7
spaghetti /spə'ɡetɪ/ 90-3
Spanish /'spæniʃ/ 44-13
Spanish club /'spæniʃ klʌb/ 23-22
sparrow /'spærəʊ/ 185-18
spatula /'spætʃələ/ 95-31
speak /spɪk/ 150-3
speaker /spɪkər/ 226-14
speeding ticket /'spɪdɪŋ tɪkɪt/
get a... /get ə/ 123-6
speedometer /spi'damətər/ 121-14
speed up /'spɪd,ʌp/ 123-5
spell /spɛl/ 20-13
sphere /sfɪr/ 193-23
spice rack /spɪs ræk/ 70-11
spider /'spɪdər/ 181-18
spill /spɪl/ 102-9
spinach /'spɪnɪʃ/ 84-4
split peas /split piːz/
stir... /stər/ 93-20
sponge /spʌndʒ/ 80-21, 189-29
spoon /spun/ 101-25
sporting event /'spɔːtɪŋ ɪ'vent/ 216-6
sporting goods store /'spɔːtɪŋ ɡʊdz stɔːr/ 48-6
sports /spɔːts/ 23-21, 209-20
sports car /spɔːts kɑːr/ 118-24
sports coat /spɔːts kəʊt/ 104-21
sports jacket /spɔːts 'dʒækɪt/ 104-21
spotlight /'spɔːtlaɪt/ 205-11
sprained wrist /spreɪnd rɪst/ 135-10
spread /spred/ 93-30
spring /sprɪŋ/ 7-12
sprinkler /'sprɪŋkələr/ 69-29
square /skwɛr/ 193-20
squash /skwɔːʃ/ 84-6
squat /skwɒt/ 37-23
squeegee /'skwiːdʒi/ 80-6
squid /skwɪd/ 189-19
squirrel /'skwɜːrəl/ 190-8
stadium /'steɪdɪəm/ 47-2
stage /steɪdʒ/ 204-6
stairs /sterz/ 67-4
stamp /stæmp/ 52-5
put a...on /put ə...ən/ 53-23
stamp machine /stæmp mə'ʃɪn/ 52-12
stand up /stænd ʌp/ 21-19, 37-15
staple /'steɪpəl/ 151-17
stapler /'steɪplər/ 155-10
staples /'steɪpəlz/ 155-27
star /stɑːr/ 176-3
starfish /'stɑːfɪʃ/ 189-28
start /stɑːt/
...school /skuːl/ 31-3
state /steɪt/ 43-13
statement /'steɪtmənt/
monthly... /'mʌnθli/ 51-10
stationary bike /'steɪʃənəri baɪk/ 218-14
station wagon /'steɪʃən wæɡən/ 118-29
statue /'stætʃu/ 59-23
steak /steɪk/ 87-10
steam /stem/ 92-10
steamer /'stiːmə/ /
vegetable... /'vedʒtəbəl/ 95-26
steel wool /stiːl wʊl/ 163-17
steering wheel /'stiːrɪŋ wiːl/ 121-24
stem /stem/ 179-15
stepfather /'step,fədər/ 27-8
stepladder /'step,lædər/ 80-23
stepmother /'step,mʌdər/ 27-5
steps /steps/ 69-15
stepsister /'step,sɪstər/ 27-12
stereo (system) /'steri,ou ('sɪstəm)/ 226-15
sterile pad /'sterəl pæd/ 143-25
sterile tape /'sterəl teɪp/ 143-26
stethoscope /'steθə,skəʊp/ 141-1
sticky notes /'stɪki nəʊtɪz/ 155-26
still life /stɪl laɪf/ 203-2
sting /stɪŋ/
bee... /bi/ 135-28
stingray /'stɪŋreɪ/ 189-20
stir /stər/ 93-20
stir-fried vegetables /stər-fraɪd 'vedʒtəbəlz/ 91-20
stitches /stɪtʃɪz/ 139-28
stockbroker /'stɒk,broʊkər/ 148-13
stockings /'stɒkɪŋz/ 107-6
stomach /'stɒmək/ 133-29
stomachache /'stɒmək,eɪk/ 135-12
stool /stul/ 70-21
stop /stɒp/ 123-10, 227-30
stop /stɒp/ 118-2
stopper /'stɒpər/ 194-22
storage space /'stɔːrɪdʒ speɪs/ 67-1
stores /stɔːrɪz/ 48-49
storm /stɔːrm/ 166-14
stove /stəʊv/ 70-6
camping... /kæmpɪŋ/ 213-15
stow /stəʊ/ 126-10
straight /streɪt/ 130-1
...skirt /skɜːt/ 111-18
straight hair /streɪt heər/ 33-17
straight leg /streɪt leg/
...jeans /dʒiːnz/ 111-11
straight line /streɪt laɪn/ 193-7
strainer /'streɪnər/ 94-18
strap /stræp/ 128-15
straw /strɔː/ 90-13
strawberries /'strɔːberɪz/ 83-25
box of... /bɒks ɒv/ 97-20
stream /striːm/ 169-6
street /striːt/ 47-27
street address /striːt ə'dres/ 43-11
streetlight /'striːtlaɪt/ 58-4
street musician /striːt myu'zɪʃən/ 59-22
street vendor /striːt 'vɛndər/ 58-12, 214-28
stretch /streɪtʃ/ 126-19
stretcher /'streɪtʃər/ 139-27
string /strɪŋ/ 207
string beans /strɪŋ biːnz/ 85-28
striped /straɪpt/ 113-20
stroller /'strəʊlər/ 57-11
strong /strɒŋ/ 14-3
student /'studnt/ 19-25
student ID /'studnt aɪ di/ 43-19
student schedule /'studnt 'skeɪdʒul/ 23-25
studio (apartment) /'studɪəʊ (ə'pɑːtmənt)/ 67-9
study /'stʌdi/ 19-33

- subtraction /səb'trækʃən/ 193-27
 suburbs /'sʌb,ɜːbz/ 63-21
 subway (train) /'sʌb'wei (treɪn)/ 128-18
 subway line /'sʌb'wei laɪn/ 128-16
 suede /sweɪd/ 113-8
 sugar /'ʃʊɡər/
 sift... /sɪft/ 93-28
 sugar bowl /'ʃʊɡər 'bəʊl/ 101-10
 suit /suːt/
 business... /'bɪznɪs/ 104-29
 suite /swɪt/ 159-5
 summer /'sʌmə/ 7-13
 sun /sʌn/ 166-9, 176-18
 sunbather /'sʌn,bet̩ə/ 211-19
 sunburn /'sʌn,bɜːn/ 135-27
 Sunday /'sʌn,deɪ/ 6-11
 sunflowers /'sʌn,flaʊəz/ 179-29
 sunglasses /'sʌn,glæsɪz/ 109-14
 sunny /'sʌni/ 167-25
 sunrise /'sʌn,raɪz/ 5
 sunscreen /'sʌn,skriːn/ 144-22, 211-24
 sunset /'sʌn,set/ 5
 sunshine /'sʌn,ʃaɪn/ 166-13
 super /'supə/ 67-3
 superintendent /,supərɪn'tendənt/ 67-3
 supermarket /'supə,mɑːkət/ 48-27, 98-99
 supervisor /'supə,vaɪzər/ 156-9
 supplies /sə'plaɪz/ 162-163
 supply cabinet /sə'plaɪ 'kæbɪnɪt/ 155-22
 Supreme Court /su'prɪm kɔːt/ 200-8
 surf /sɜːf/ 210-30
 surfboard /'sɜːf,bɔːd/ 211-16
 surfer /sɜːfər/ 211-15
 surgeon /'sɜːdʒən/ 139-10
 surgical mask /'sɜːdʒɪkəl mæsk/ 139-13
 surname /'sɜːneɪm/ 43-2
 surprised /sər'praɪzəd/ 39-22
 sushi /'suːʃi/ 91-23
 suspenders /sə'spendəz/ 109-5
 suspense /sə'spens/ 208-3
 SUV /es yu vi/ 118-22
 swallow /'swaləʊ/ 136-10
 sweater /'swetər/ 104-20
 cardigan... /'kɑːdɪ,gən/ 111-15
 crew neck... /kru nek/ 111-14
 turtleneck... /'tɜːtl,nek/ 111-16
 V-neck... /vi-nek/ 111-13
 sweatpants /swetpænts/ 104-4
 sweatshirt /swetʃɜːt/ 104-3
 sweep /swɪp/ 79-4
 sweet potato /swit pə'tetəʊ/ 84-22
 swim /swɪm/ 210-32
 swimmer /swɪmə/ 211-8
 swimming pool /'swɪmɪŋ pul/ 159-21, 218-34
 swimming trunks /'swɪmɪŋ trʌŋks/ 107-9
 swimsuit /'swɪm,suːt/ 107-7
 swimwear /'swɪm,wɛə/ 106-107
 swing /swɪŋ/ 183-26
 swings /swɪŋz/ 214-2
 Swiss cheese /swɪs 'tʃiːz/ 88-24
 switch /swɪtʃ/
 light... /laɪt/ 72-24
 swollen ankle /'swʊlən 'æŋkəl/ 135-11
 swordfish /'sɔːd,fɪʃ/ 87-23, 189-3
 symptoms /'sɪmptəmz/ 134-135
 synagogue /'sɪnə,gɑːg/ 47-7
 syrup /'sɪrəp/ 88-13
 table /'teɪbəl/ 19-17, 70-32
 bus the... /bʌs ðə/ 102-25
 clear the ... /klaɪə ðə/ 102-25
 set the... /set ðə/ 102-5
 wipe the... /waɪp ðə/ 102-22
 tablecloth /'teɪbəl,kləʊθ/ 101-11
 tablespoon /'teɪbəl,spun/ 97-5
 tablespoon /'teɪbəl,spun/ 96
 tablet /'tæblɪt/ 142-1
 taco /'takəʊ/ 91-26
 tail /teɪl/ 185-29
 taillight /'teɪl,laɪt/ 121-5
 tailor /'teɪlə/ 117-19
 take /teɪk/
 ...a bath /ə bæθ/ 34-22
 ...a break /ə breɪk/ 20-14
 ...a coffee break /ə 'kɔːfi breɪk/ 34-12
 ...a message /ə 'mesɪdʒ/ 150-12
 ...a nap /ə næp/ 34-15
 ...an order /ən 'ɔːdə/ 102-11
 ...a photograph /ə 'fəʊtə,græf/ 203-26
 ...a pill /ə pil/ 137-27
 ...a shower /ə 'ʃaʊə/ 34-4
 ...a test /ə test/ 19-34
 ...a vacation /ə veɪ'keɪʃən/ 31-19
 ...a walk /ə wɔːk/ 34-20
 ...care of /keɪ əv/ 150-9
 ...home /həʊm/ 114-6
 ...your child to school /jər ʃaɪld tə skuːl/ 34-10
 ...your temperature /jər 'tempərəʃər/ 137-19
 take off /teɪk əf/ 114-17, 126-13
 take out /teɪk aʊt/ 79-19
 taking a flight /teɪkɪŋ ə flaɪt/ 126-127
 talk /tɔːk/ 21-20
 talk show /tɔːk ʃəʊ/ 209-17
 tail /teɪl/ 14-17
 tambourine /,tæmbə'reɪn/ 207-3
 tan /tæn/ 10-17
 tangerine /,tændʒə'reɪn/ 83-28
 tank top /tæŋk tɒp/ 107-25
 tape /teɪp/ 155-9, 226-16
 duct... /dʌkt/ 163-31
 masking... /mæskɪŋ/ 163-13
 tape measure /teɪp 'meʒə/ 117-28, 163-3
 tape recorder /teɪp rɪ'kɔːdə/ 19-24
 tarantula /tə'reɪnʃələ/ 182-25
 taupe /təʊp/ 10-18
 taxes /'tæksəz/
 pay... /peɪ/ 201-16
 taxi /'tæksi/ 128-4
 taxi driver /'tæksi 'draɪvər/ 128-5, 148-17
 taxi stand /'tæksi stænd/ 128-1
 tea /ti/ 90-12
 teacher /'tiːʃər/ 19-2, 148-9
 teachers' lounge /'tiːʃəz laʊndʒ/ 23-9
 tea kettle /ti 'kɛtl/ 70-7
 teal /tiːl/ 10-8
 team /tiːm/ 23-2
 teapot /'tiːpət/ 70-29
 tear down /teə daʊn/ 165-16
 teaspoon /'tiːspun/ 96, 97-4
 teenager /'tiːn,eɪdʒər/ 30
 teeth /tiːθ/
 brush... /brʌʃ/ 34-3
 teething ring /'tiːðɪŋ rɪŋ/ 57-7
 telephone /'telə,fəʊn/ 16-17, 155-12
 telephone book /'telə,fəʊn bʊk/ 16-8
 telephone number /'telə,fəʊn 'nʌmbər/ 16-23, 43-9
 telescope /'telə,skəʊp/ 176-9
 television /'telə,vɪʒən/ 226-19
 watch... /wɔːtʃ/ 34-25
 teller /'telər/ 51-4
 teller window /'telər 'wɪndəʊ/ 51-5

- temperature /'tempərəʃər/ 135-15
 take your... /teɪk jər/ 137-19
- ten /ten/ 2
 tenant /'tenənt/ 67-10
 ten cents /ten sentz/ 8-3
 ten-dollar bill /ten-'dɒlə bɪl/ 8-8
 ten dollars /ten 'dɒlərz/ 8-8
 tennis /'tenɪs/ 220-1
 tennis ball /'tenɪs bɔːl/ 220-3
 tennis racket /'tenɪs 'rækɪt/ 220-2
 tent /tent/ 63-2, 213-24
 tenth /tenθ/ 3
 ten thousand /ten 'θaʊzənd/ 2
 terminal /'tɜːmɪnəl/ 124-1
 termites /'tɜːmɪts/ 76-26
 test /test/ 19-29
 cheat on a... /ʃiːt ən ə/ 18-31
 fail a... /feɪl ə/ 18-32
 pass a... /pæs ə/ 19-35
 study for a... /'stʌdi fɔː ə/ 19-33
 take a... /teɪk ə/ 19-34
 test tube /test tʌb/ 194-13
 text /tekst/
 select... /sə'lekt/ 24-32
 textbook /'tekst,bʊk/ 19-30
 Thai /taɪ/ 44-26
 thank /θæŋk/ 102-21
 Thanksgiving /'θæŋks,grɪvɪŋ/ 229-16
 theater /'θiətər/ 47-11
 theft /θeft/ 61-4
 thermometer /θɜː'mamətər/ 143-30, 166-8
 meat... /miːt/ 94-17
 thermostat /'θɜːrmoʊ'stæt/ 72-25
 thigh /θaɪ/ 133-13
 thighs /θaɪz/ 87-27
 thimble /'θɪmbəl/ 117-26
 thin /θɪn/ 15-26
 third /θɜːrd/ 3
 thirsty /θɜːrsti/ 39-11
 thirteen /θɜː'tɪn/ 2
 thirteenth /θɜː'tɪnθ/ 3
 thirty /'θɜːrti/ 2
 thongs /θɔːŋz/ 107-10
 thread /θred/ 117-27
 embroidery... /ɛm'brɔɪdəri/ 224-23
 three /θri/ 2
 three-fourths /θri-fɔːθs/ 3
 three quarters /θri 'kwɔːtərs/ 3
 thrift shop /θrɪft ʃɔːp/ 48-14
 throat /θroʊt/ 133-25
 throat lozenges /θroʊt 'lɔːzəndʒz/ 142-9
 through /θruː/ 130-4
 throw pillow /θrou 'pɪləʊ/ 72-9
 throw up /θrou ʌp/ 137-18
 thumb /θʌm/ 133-6
 thumbtack /'θʌm,tæk/ 155-23
 Thursday /'θɜːrz,deɪ/ 6-8
 tick /tɪk/ 190-25
 ticket /'tɪkɪt/ 124-2, 128-11, 205-22
 ticket counter /'tɪkɪt 'kaʊntər/ 124-4
 ticket window /'tɪkɪt 'wɪndəʊ/ 128-10
 tidal wave /'taɪdəl weɪv/ 171-10
 tie /taɪ/ 104-28
 narrow... /'næroʊ/ 111-9
 wide... /waɪd/ 111-8
 tiger /'taɪgər/ 182-9
 tight /taɪt/
 ...skirt /skɜːrt/ 111-17
 tights /taɪts/ 107-4
 tile /taɪl/ 163-7
- time /taɪm/ 4-5
 time card /taɪm kɑːrd/ 157-11
 time clock /taɪm klɒk/ 157-12
 timer /'taɪmər/
 kitchen... /'kɪtʃən/ 94-7
 times /taɪmz/ 193-5
 times of day /taɪmz ʌv deɪ/ 5
 time zones /taɪm zəʊnz/ 16-12
 tip /tɪp/
 leave a... /liːv ə/ 102-23
 fire /faɪə/ 121-4
 change the... /tʃeɪnʒ ðə/ 123-22
 tired /taɪəd/ 39-23
 fires /faɪəz/
 put air in the... /pʊt ɛr ɪn ðə/ 123-18
 tissues /'tɪʃuz/ 144-25
 title /'taɪtl/ 55-19, 196-8
 toad /toʊd/ 190-20
 toaster /'toʊstər/ 70-13
 toboggan /tə'bagən/ 222-7
 today /tə'deɪ/ 6-3
 toddler /'tɒdlər/ 56-33
 toe /toʊ/ 133-18
 tofu /'toʊfu/ 88-11
 toilet /'toɪlɪt/ 75-25
 ...is clogged /ɪz klɒgəd/ 77-2
 scrub the... /skrʌb ðə/ 79-11
 toilet brush /'toɪlɪt brʌʃ/ 75-30
 toilet paper /'toɪlɪt 'peɪpər/ 75-24
 toilet tissue /'toɪlɪt 'tɪʃu/ 75-24
 token /'təʊkən/ 128-20
 toll /toʊl/
 pay a... /peɪ ə/ 123-23
 tomato /tə'meɪtoʊ/ 84-7
 tomatoes /tə'meɪtoʊz/
 pile of... /paɪl ʌv/ 97-28
 tomorrow /tə'mɔːroʊ/ 6-4
 tongue /tʌŋ/ 133-43
 toolbar /tuːlbər/ 25-4
 tool belt /tuːl belt/ 160-12
 tools /tuːlz/ 160-161
 tooth /tuːθ/ 133-44, 141-28
 toothbrush /'tuːθ,brʌʃ/ 144-15
 toothpaste /'tuːθ,peɪst/ 144-14
 tornado /tɔː'neɪdoʊ/ 171-11
 tortilla /tɔː'tɪliə/ 91-29
 tortoise /'tɔːtɔɪs/ 181-12
 total /'toʊtl/ 9-20
 to the left of /tə ðə left ʌv/ 13-8
 to the right of /tə ðə raɪt ʌv/ 13-9
 touch /tʌʃ/ 40-5
 touchpad /tʌʃpæd/ 25-24
 tour guide /tuːr gaɪd/ 148-22
 tourist information booth /'tʊrɪst ɪnfə'meɪʃən buːθ/ 59-21
 toward /tɔːrd/ 130-7
 towel /'taʊəl/ 75-26
 town hall /taʊn hɔːl/ 47-17
 townhouse /'taʊn,haʊs/ 63-12
 tow truck /tuː trʌk/ 118-13
 toys /tɔɪz/ 57-15, 224-225
 toy store /tɔɪ stɔːr/ 48-7
 track /træk/ 128-14, 220-16, 220-18
 trackpad /trækpæd/ 25-24
 tractor /'træktər/ 152-4
 tractor trailer /'træktər 'treɪlər/ 118-25
 traffic accident /'træfɪk 'æksɪdənt/ 58-5
 traffic cop /'træfɪk kɒp/ 58-6
 traffic signs /'træfɪk saɪnz/ 118
 trail /treɪl/
 hiking... /'haɪkɪŋ/ 213-14, 216-11

- trailer /'treɪlə/ 118-23
 trail map /treɪl məp/ 213-18
 train /treɪn/ 128-12
 subway... /'sʌb,weɪ/ 128-18
 training pants /'treɪnɪŋ/ 57-28
 TRANSPORTATION /'træns'pɔ:t'eɪʃən/ 118-131
 trash /træʃ/
 put out the... /pʊt aʊt ðə/ 79-19
 take out the... /teɪk aʊt ðə/ 79-19
 trash bags /træʃ bægz/ 80-8
 trash can /træʃ kæn/ 69-19, 214-9
 travel /'trævl/ 31-23
 travel agency /'trævl 'eɪdʒənsi/ 58-13
 travel agent /'trævl 'eɪdʒənt/ 148-27
 traveler's check /'trævlərz tʃek/ 9-24
 tray /treɪ/ 101-29
 carry a... /'kæri ə/ 102-4
 ...of pastries /ʌv 'peɪstrɪz/ 97-11
 paint... /peɪnt/ 163-15
 tray table /treɪ 'teɪbəl/
 put down your... /pʊt daʊn jə/ 126-18
 treadmill /'tred,mɪl/ 218-15
 tree /tri/
 birch... /bɜ:ʃ/ 179-3
 Christmas... /'krɪsməs/ 229-22
 elm... /ɛlm/ 179-6
 maple... /'meɪpəl/ 179-4
 oak... /oʊk/ 179-5
 pine... /paɪn/ 179-1
 willow... /'wɪləʊ/ 179-2
 trench /trentʃ/
 dig a... /dɪg ə/ 165-22
 trench coat /trentʃ kəʊt/ 104-19
 trial /'traɪəl/ 61-21
 triangle /'traɪ,æŋɡəl/ 193-19
 tripod /'traɪ,pɒd/ 226-5
 trombone /'trɒm'boʊn/ 207-8
 trousers /'traʊzəz/ 104-22
 trout /traʊt/ 87-25
 truck /trʌk/
 load a... /ləʊd ə/ 64-10
 pickup... /'pɪkʌp/ 118-15
 truck driver /trʌk 'draɪvə/ 148-26
 trumpet /'trʌmpət/ 207-9
 trunk /trʌŋk/ 121-3, 179-11, 185-25
 trunks /trʌŋks/
 swimming... /'swɪmɪŋ/ 107-9
 try on /'traɪ ɒn/ 114-4
 T-shirt /'ti-ʃɜ:t/ 104-25
 tsunami /su'nami/ 171-10
 tuba /'tʊbə/ 207-6
 tube /tʊb/
 ...of hand cream /ʌv hænd krem/ 97-9
 Tuesday /'tu:zdeɪ/ 6-6
 tulips /'tʊlɪps/ 179-25
 tuna /'tu:nə/ 87-26, 189-10
 tunnel /'tʌnəl/
 out of the... /aʊt ʌv ðə/ 130-5
 into the... /'ɪntu ðə/ 130-3
 through the... /θru ðə/ 130-4
 turkey /'tɜ:ki/ 87-30, 152-27, 190-12, 229-17
 Turkish /'tɜ:kiʃ/ 44-16
 turnip /'tɜ:nɪp/ 84-17
 turn off /tɜ:n ɔ:f/ 126-11
 turn on /tɜ:n ɒn/
 ...the headlights /ðə 'hed,laɪts/ 123-7
 ...the overhead light /ði 'oʊvə'hed laɪt/ 126-15
 turn signal /tɜ:n 'sɪɡnəl/ 121-36
 turnstile /'tɜ:n,steɪl/ 128-23
 turquoise /'tɜ:kwoɪz/ 10-10
 turtle /'tɜ:tl/ 189-8
 turtleneck /'tɜ:tlnek/
 ...sweater /'swetə/ 111-16
 tusk /tʌsk/ 185-24, 187-17
 tuxedo /tʌk'sɪdəʊ/ 104-6
 TV /ti'vi/ 226-19
 TV programs /ti'vi 'prəʊ,græmz/ 209
 tweezers /'twi:zəz/ 143-31
 twelfth /twelfθ/ 3
 twelve /twelv/ 2
 twentieth /'twentiəθ/ 3
 twenty /'twenti/ 2
 twenty-dollar bill /'twenti-dələr bɪl/ 8-9
 twenty dollars /'twenti dələrz/ 8-9
 twenty-first /'twenti-fɜ:st/ 3
 twenty-five after six /'twenti-faɪv 'æftə sɪks/ 5
 twenty-five cents /'twenti-faɪv sentz/ 8-4
 twenty-five of seven /'twenti-faɪv ʌv 'sevən/ 5
 twenty-five past six /'twenti-faɪv pæst sɪks/ 5
 twenty-five to seven /'twenti-faɪv tə 'sevən/ 5
 twenty-one /'twenti-wʌn/ 2-21
 two /tu/ 2
 two-family house /tu-'fæməli haʊs/ 63-6
 two-thirds /tu-θɜ:rdz/ 3
 type /taɪp/ 150-8, 196-25
 types of homes /taɪps ʌv hoʊmz/ 62-63
 typewriter /'taɪp,raɪtə/ 155-1
 ugly /'ʌgli/ 14-13
 ultrasound /'ʌltrə'saʊnd/ 141-12
 umbrella /ʌm'brelə/ 109-4
 unbuckle /ʌn'bʌkəl/ 114-16
 unbutton /ʌn'bʌtn/ 114-14
 uncle /'ʌŋkəl/ 27-4
 uncomfortable /ʌn'kʌmfətbəl/ 39-25
 unconscious /ʌn'kɒnʃəs/
 be... /bi/ 136-2
 under /'ʌndə/ 13-13, 130-13
 underline /'ʌndə,laɪn/ 21-27
 underneath /'ʌndə,niθ/ 13-16
 underpants /'ʌndə,pænts/ 107-20
 undershirt /'ʌndə,ʃɜ:t/ 107-24
 underwear /'ʌndə,wɛr/ 106-107
 unfasten /ʌn'fæsn/ 126-22
 unfurnished apartment /ʌn'fɜ:nɪʃt ə'pɑ:tmənt/ 67-20
 uniform /'ju:nə,fɔ:m/ 104-13, 220-22
 United States /ju'naitəd steɪts/ 172-173
 Universe /'ju:nə,vɜ:rs/ 176-177
 unpack /ʌn'pæk/ 64-11
 unzip /ʌn'zɪp/ 114-15
 up /ʌp/ 130-10
 upside down /'ʌn,sɑɪd 'daʊn/ 130-12
 Uranus /ju'reɪnəs/ 176-22
 urban area /'ɜ:bən 'eəriə/ 63-20
 U.S. Constitution /ju'es,kən'stə'tju:ʃən/ 200-5
 U.S. government /ju'es'gʌvənmənt/ 200-201
 use /ju:z/
 ...a computer /ə kəm'pyʊtə/ 151-21
 usher /'ʌʃə/ 205-21
 utility knife /ju'tɪləti naɪf/ 160-1
 vacuum /'væk,yʊm/ 79-7
 vacuum (cleaner) /'væk,yʊm (k'lɪnə/ 80-5
 vacuum cleaner attachments /'væk,yʊm,k'lɪnə,'ə'tæʃmənts/
 80-4
 vacuum cleaner bag /'væk,yʊm,k'lɪnə,bæg/ 80-3
 Valentine's Day /'vælən,tainz,deɪ/ 228-4
 valet parking /væ'leɪ,pɑ:kɪŋ/ 159-23
 valley /'væli/ 169-5
 van /væn/ 118-20
 load a... /ləʊd ə/ 64-10
 vandalism /'vændlɪzəm/ 61-12

- vase /veɪs/ 101-9
 vault /vɔːlt/ 51-3
 VCR /'viːsɪ'ɑːr/ 226-21
 veal cutlets /'viːl,kʌt'lɪts/ 87-13
 vegetable peeler /'vedʒtəbəl ,piːlə/ 94-14
 vegetables /'vedʒtəbəlz/ 84-85
 vegetable steamer /'vedʒtəbəl ,stɪmə/ 95-26
 vehicle registration card /'viːkəl ,reɪdʒɪ'streɪʃən kɑːd/ 43-16
 vehicles /'viːkəlz/ 118-119
 velvet /'velvɪt/ 113-3
 Venezuelan /,venə'zweɪlən/ 44-4
 vent /vent/ 72-23
 Venus /'vɪnəs/ 176-27
 vest /vest/ 104-26
 safety... /'seɪfəti/ 157-27
 vet /vet/ 148-28
 veterinarian /,vetərə'nɛəriən/ 148-28
 vice president /vaɪs 'prezədənt/ 200-12
 victim /'vɪktɪm/ 61-16
 video(cassette) /'vɪdiəʊ(kə'set)/ 226-22
 video arcade /'vɪdiəʊ ɑːr'keɪd/ 216-18
 videocassette recorder /'vɪdiəʊkə'set rɪ'kɔːdə/ 226-21
 video game system /'vɪdiəʊ geɪm 'sɪstəm/ 226-20
 video store /'vɪdiəʊ stɔː/ 48-18
 Vietnamese /'viːetnə,mɪz/ 44-27
 Vikings /'vaɪkɪŋz/
 ...sail /seɪl/ 198-4
 villa /'vɪlə/ 63-11
 vine /'vaɪn/ 182-2
 vineyard /'vaɪnɔːd/ 152-8
 violet /'vaɪələt/ 10-15
 violets /'vaɪələts/ 179-23
 violin /,vaɪə'lɪn/ 207-21
 visa /'vɪzə/ 43-23
 vise /vaɪs/ 160-13
 visit /'vɪzɪt/ 40-3
 visitor /'vɪzɪtə/ 139-17
 vitamins /,vaɪtə'mɪnz/ 142-20
 V-neck /'vi-,nek/
 ...sweater /'swetə/ 111-13
 volcanic eruption /vəl'kænik ɪ'rʌpʃən/ 171-12
 volcano /vəl'keɪmou/ 169-3
 volleyball /'vɒli,bɔːl/ 220-9
 volleyball /'vɒli,bɔːl/ 220-10
 volleyball net /'vɒli,bɔːl net/ 220-11
 vomit /'vɒmɪt/ 137-18
 vote /vəʊt/ 201-14
 voting booth /vəʊtɪŋ buːθ/ 200-3
 vulture /'vʌltʃə/ 181-9
 waist /'weɪst/ 133-11
 wait /weɪt/ 126-7
 waiter /'weɪtə/ 101-6
 waiting room /'weɪtɪŋ rum/ 141-6
 wait on /weɪt ən/ 102-6
 waitress /'weɪtrɪs/ 101-4
 wake up /weɪk ʌp/ 34-1
 walk /wɔːk/ 37-13
 walk /wɔːk/
 learn to... /lɜːn tə/ 31-2
 take a... /teɪk ə/ 34-20
 walk(way) /wɔːk(weɪ)/ 69-28
 wall /wɔːl/ 72-21
 ...is cracked /ɪz krækt/ 77-4
 paint a... /peɪnt ə/ 165-3
 plaster a... /'plæstə ə/ 165-2
 tear down a... /teə daʊn ə/ 165-16
 wallet /'wɒlɪt/ 109-15
 wall unit /wɔːl 'juːnɪt/ 72-7
 walnuts /'wɒl,nʌts/ 83-34
 walrus /'wɒlrʌs/ 187-15
 warehouse /'weɪ,hɑːs/ 157-15
 warm /wɔːm/ 166-4
 warning label /'wɔːnɪŋ 'leɪbəl/ 142-16
 wash /wɒʃ/ 114-18
 ...the car /ðə kɑː/ 79-16
 ...the dishes /ðə dɪʃəz/ 79-21
 ...the windshield /ðə 'wɪndʃɪld/ 123-17
 washcloth /'wɒʃ,kləθ/ 75-29
 washer /'wɒʃə/ 116-7, 163-26
 washing machine /'wɒʃɪŋ mə'ʃɪn/ 116-7
 wasp /wɒsp/ 182-23
 waste /weɪst/
 hazardous... /'hæzərdəs/ 171-18
 wastebasket /'weɪst,bæskɪt/ 75-31
 empty the... /'empti ðə/ 79-13
 watch /wɒʃ/ 34-25
 watch /wɒʃ/ 109-11
 water /'wɔːtə/ 79-18, 153-30
 water /'wɔːtə/ 211-5
 liter of... /'lɪtə əv/ 97-17
 pour... /pɔː/ 102-2
 water bottle /'wɔːtə 'bɒtl/ 213-13
 waterfall /'wɔːtə,fɔːl/ 169-9
 water fountain /'wɔːtə 'faʊntɪn/ 23-11
 water glass /'wɔːtə glæs/ 101-16
 water heater /'wɔːtə 'hiːtə/ 67-6
 watermelon /'wɔːtə 'melən/ 83-6
 water meter /'wɔːtə 'mɪtə/ 77-19
 water park /'wɔːtə pɑːk/ 216-21
 water pollution /'wɔːtə pə'ljuːʃən/ 171-19
 water-skier /'wɔːtə-,skɪə/ 211-3
 water wing /'wɔːtə wɪŋ/ 211-23
 wave /weɪv/ 40-20
 wave /weɪv/ 211-9
 tidal... /'taɪdl/ 171-10
 wavy hair /'weɪvi heə/ 33-19
 weak /wiːk/ 14-4
 wear /weə/ 114-13
 wearing clothes /weɪnɪŋ kləʊz/ 114-115
 weather /'weðə/ 166-167
 Web /web/ 25-29
 Wednesday /'wenzdeɪ/ 6-7
 weed /wiːd/ 79-15
 week /wiːk/ 4
 weekdays /'wiːk,deɪz/ 6
 weekend /'wiːk,ɛnd/ 6
 weigh /weɪ/ 53-22
 weightlifter /weɪt,lɪftə/ 218-26
 weightlifting /weɪt,lɪftɪŋ/ 218-25
 weld /weld/ 165-12
 west /west/ 130-22
 West Coast /west kəʊst/ 172-7
 western /'westərn/ 208-7
 wet clothes /wet kləʊz/ 116-8
 whale /weɪl/ 187-14
 killer... /'kɪlə/ 189-7
 wheel /wiːl/
 produce the... /'prəʊ,dʌs ði/ 198-2
 wheelbarrow /'wiːl,bərou/ 69-26
 push a... /pʊʃ ə/ 165-20
 wheelchair /'wiːl,tʃeə/ 139-23
 whisk /wɪsk/ 92-3
 whisk /wɪsk/ 95-20
 whiskers /wɪskəz/ 187-16
 white /waɪt/ 10-20
 whiteboard /waɪt,bɔːd/ 19-14
 White House /waɪt haʊs/ 200-7
 wide /waɪd/
 ...tle /tɪl/ 111-8
 width /wɪdθ/ 193

wife /waɪf/ 27-26
willow (tree) /'wɪləʊ (tri)/ 179-2
wind /wɪnd/ 166-17, 171-24
windbreaker /'wɪnd,breɪkər/ 104-7
window /'wɪndəʊ/ 25-3, 69-10
 install a... /ɪn'stɔːl ə/ 165-13
 ...is broken /ɪz 'brəʊkən/ 77-10
window seat /'wɪndəʊ sit/ 72-10
window shade /'wɪndəʊ ʃeɪd/ 74-8
windshield /'wɪnd,ʃɪld/
 wash the... /wɒʃ ðə/ 123-17
windshield wiper /'wɪnd,ʃɪld 'waɪpər/ 121-29
windy /'wɪndi/ 167-27
wine glass /waɪn glæs/ 101-15
wing /wɪŋ/ 187-21
wing nut /wɪŋ nʌt/ 163-24
wings /wɪŋz/ 87-28
wins /wɪnz/ 198-16
winter /'wɪntər/ 7-15
winter sports /'wɪntər spɔːrts/ 222-223
wipe /waɪp/ 102-22
wipes /waɪps/
 baby... /'beɪbi/ 57-24
wire /waɪr/ 165-8
wire /waɪr/ 160-21
wire stripper /waɪr 'stri:pər/ 160-23
withdraw /wɪð'drɔː/ 51-26
withdrawal /wɪð'drɔːl/ 51-17
witness /'wɪtnɪs/ 61-17
wok /wɒk/ 95-28
wolf /wɒlf/ 187-4
woman /'wʊmən/ 15-40
wood /wʊd/ 163
 glue... /glu/ 165-24
 plane... /pleɪn/ 165-23
 sand... /sænd/ 165-25
 saw... /sɔː/ 165-10
wooden spoon /'wʊdn spun/ 94-9
woodlands /'wʊdlænds/ 190-191
woodpecker /'wʊd,pɛkər/ 190-13
woodwind /'wʊd,wɪnd/ 207
wool /wʊl/ 113-12
word /wɜːrd/ 196-2
 look up a... /lʊk ʌp ə/ 20-8
WORK /wɜːk/ 146-165
work /wɜːk/ 77-7
 go to... /gəʊ tə/ 34-11
workbook /'wɜːk,bʊk/ 19-18
worker /'wɜːkər/ 156-4
working /'wɜːkɪŋ/ 150-151

work out /wɜːk aʊt/ 34-16
workout room /'wɜːk,aʊt rum/ 67-15
World /wɜːld/ 174-175
World Wide Web /wɜːld waɪd web/ 25-29
worm /wɜːm/ 190-18
worried /wɜːrɪd/ 39-15
wrap /ræp/
 ...a present /ə 'prezənt/ 229-29
wrench /rentʃ/ 160-10
 pipe... /paɪp/ 161-25
wrestler /'reslər/ 218-22
wrestling /'reslɪŋ/ 218-21
wrinkle /'rɪŋkəl/ 33-10
wrist /rɪst/ 133-7
 sprained... /spreɪnd/ 135-10
wristwatch /rɪst wɒtʃ/ 109-11
write /raɪt/ 20-6
 ...a draft /ə dræft/ 196-22
 ...a letter /ə 'letər/ 40-8
 ...an outline /ən 'aʊtlaɪn/ 196-21
writer /'raɪtər/ 55-21, 148-25
writing /'raɪtɪŋ/ 196-197
X-ray /'ɛks-reɪ/ 138-6
yard /jɑːd/ 69-20, 162
yarn /'jɑːn/ 224-21
year /jɪr/ 4
yellow /'jeləʊ/ 10-12
yesterday /'jestər,deɪ/ 6-2
yield /jɪld/ 118-10
yoga /'jəʊgə/ 218-2
yogurt /'jəʊgət/ 88-12
 container of ... /kən'teɪnər ʌv/ 97-25
young /jʌŋ/ 14-22
zebra /'zɪbrə/ 185-12
zero /'zɪrəʊ/ 2
zip /zɪp/ 114-9
zip code /zɪp kəʊd/ 43-14, 52-7
zipper /'zɪpər/ 117-24
zoo /zuː/ 216-2
zoom lens /zum lenz/ 226-2
zucchini /zu'kɪni/ 84-11

Credits

Illustrators

Denny Bond: pp. 38-39, 48-51, 90-91, 106-107, 130-131, 190-191, 202-203, 214-215 (©Denny Bond)
Higgins Bond: pp. 184-185, 212-213 (©Higgins Bond/Anita Grien)
James Edwards: pp. 9, 18-19, 34-37, 64-65, 116-117, 122-123 (©James Edwards/The Beranbaum Group)
Mike Gardner: pp. 32-33, 110-111, 145 (32-37), 146-151, 200-201, 228-229 (©Mike Gardner)
Patrick Gnan: pp. 68-69, 168-169, 178-179 (©Patrick Gnan/illustrationOnline.com)
Gershon Griffith: pp. 20-21, 26-27, 100-101, 104-105, 126-127, 196 (20-25), 220-221 (©Gershon Griffith/Craven Design)
Lane Gregory: pp. 114-115 (©Lane Gregory/Gwen Walters Artist Representative)
Sharon and Joel Harris: pp. 132-133, 182-183 (©Sharon and Joel Harris/illustrationOnline.com)
Phil Howe: pp. 3, 58-59, 70-71, 92-95 (©Phil Howe/illustrationOnline.com)
Ken Joudrey: pp. 52-53 (©Ken Joudrey/Munro Campagna)
Bob Kayganich: pp. 5, 12-13, 14 (21, 22, 31, 32), 15 (17, 18, 27, 28, 29, 30), 16 (4-6, 9-11), 17 (12-19, 24-27), 24-25, 54-55, 76-77, 96-97, 176-177, 180-181, 194 (1, 10, 11, 12), 195 (3, 5, 17, 19) (©Bob Kayganich/illustrationOnline.com)
Alan King: pp. 10-11, 46-47, 120-121, 142-143, 154-155, 210-211 (©Alan King/illustrationOnline.com)
Barbara Kiwak: pp. 28-29, 60-61, 102-103, 108-109, 204-205 (©Barbara Kiwak/Gwen Walters Artist Representative)
Greg LaFever: pp. 152-153, 222-224 (©Greg LaFever/Scott Hull Associates)
Mapping Specialists: pp. 44-45, 172-175 (©Mapping Specialists)
Precision Graphics: pp. 22 (24, 25), 23 (26, 27), 30-31, 42-43, 50 (10-13), 51 (14, 19), 52 (1, 2, 3, 8), 78-79, 118-119, 124-125, 134-137, 140-141, 158-159, 162 (1, 2), 164-167, 186-189, 201 (5-13), 218-219, 227 (26-31) (©Precision Graphics)
John Schreiner: pp. 80-81, 86-87 (©John Schreiner/illustrationOnline.com)
Dave Schweitzer: pp. 208-209 (©Dave Schweitzer/Munro Campagna)
Beryl Simon: pp. 170-171 (©Beryl Simon)
Carol Stutz: pp. 198-199, 216-217 (©Carol Stutz)
Gerad Taylor: pp. 6-7, 66-67, 72-75, 88-89, 98-99, 128-129, 192-193 (©Gerad Taylor/illustrationOnline.com)
Gary Torrisi: pp. 22-23, 138-139, 156-157 (©Gary Torrisi/Gwen Walters Artist Representative)
Meryl Treatner: pp. 56-57, 112-113 (©Meryl Treatner/Chris Tugeau)

Photos

All photographs not otherwise credited are owned by ©Thomson/ELT.

Unit One UNIT ICON CREDIT: ©Tom Grill/CORBIS; 2 all: ©Hemera Photo-Objects; 3 center: ©Hemera Photo-Objects; 4 center: ©Hemera Photo-Objects; 4 bottom: ©Royalty-Free/CORBIS; 5 all: ©Hemera Photo-Objects; 6 bottom: ©F.SCHLUSSER/PHOTOLINK/Getty; 8 bottom: ©C Squared Studios/Getty; 14 most: ©Hemera Photo-Objects; 14 (12): ©Thinkstock LLC/Index Stock Imagery, Inc.; 14 (14): ©Louis K. Meisel Gallery/CORBIS; 14 (33): ©Paul Sonders/CORBIS; 14 (34): ©Tom Brakefield/CORBIS; 15 (3): ©Dmitri Iundt/CORBIS; 15 (4): ©Randy Faris/CORBIS; 15 (5, 6, 27): ©John Coletti; 15 (15, 16): ©C Squared Studios/Getty; 15 (25): ©Melissa Goodrum; 15 (26): ©Catherine Ledner/Stone/Getty; 15 (35, 36): ©Jacque Denzier Parker/Index Stock Imagery; 15 (37, 38, 39, 40): ©Hemera Photo-Objects; 16 left: ©Scott Baxter/Getty; 16 center: ©David Buffington/Photodisc Green/Getty; 17 bottom left: ©COMSTOCK Images

Unit Two UNIT ICON CREDIT: ©Royalty-Free/CORBIS; 24 top right: ©Hemera Photo-Objects; 24 bottom left: ©David Shopper/Index Stock Imagery, Inc.

Unit Three UNIT ICON CREDIT: ©Thinkstock/Getty; 27: ©Royalty-Free/CORBIS; 29 top left: ©SW Productions/Photodisc Green/Getty; 29 top right: ©Royalty-Free/CORBIS; 29 center left: ©Jerry Koontz/Index Stock Imagery, Inc.; 29 center right: ©Zefa Visual Media-Germany/Index Stock Imagery, Inc.; 29 bottom left (small): ©Chris Carroll/CORBIS; 29 bottom left (big): ©Hemera Photo-Objects; 29 bottom right (small): ©Ariel Skelley/CORBIS; 29 bottom right (big): ©Royalty-Free/CORBIS

Unit Four UNIT ICON CREDIT: ©Jose Luis Pelaez, Inc./CORBIS; 40 (1): ©Ghislain & Marie David de Lossy/The Image Bank/Getty; 40 (7): ©Stewart Cohen/Index Stock Imagery, Inc.; 40 (8, 16, 18, 20): ©Hemera Photo-Objects; 40 (9): ©Michael Newman/PhotoEdit; 40 (10): ©Jerry Tobias/CORBIS; 40 (15): ©David Young-Wolff/PhotoEdit; 40 (17): ©Patrick Giardino/CORBIS; 40 (19): ©Don Romero/Index Stock Imagery, Inc.; 41 (3): ©Francisco Cruz/SuperStock; 41 (4, 11, 22): ©Hemera Photo-Objects; 41 (5): ©GeoStock/Photodisc Green/Getty; 41 (12): ©Royalty-Free/CORBIS; 41 (13): ©SW Productions/Index Stock Imagery, Inc.; 41 (14): ©SuperStock; 41 (21): ©Morocco Flowers/Index Stock Imagery, Inc.; 41 (23): ©Steve Prezant/CORBIS; 41 (24): ©Myrleen Ferguson Cate/PhotoEdit; 42 top: ©Shuji Kobayashi/Stone/Getty; 42 center: ©Image Source/SuperStock; 42 bottom: ©Michael Newman/PhotoEdit; 44 top left: ©Hemera Photo-Objects; 44 top right: ©Springfield Photography/Alamy; 44 bottom left: ©Peter Guttman/CORBIS; 44 bottom right: ©Hemera Photo-Objects; 45 all: ©Hemera Photo-Objects

Unit Five UNIT ICON CREDIT: ©Photodisc Collection/Getty; 54: ©Mitchell Gerber/CORBIS; 56 top right: ©Hemera Photo-Objects; 56 center left: ©Willie Holdman/Index Stock Imagery Inc.; 56 center right: ©Stewart Cohen/Taxl/Getty; 56 bottom left: ©Chris Carroll/CORBIS; 56 bottom right: ©Hemera Photo-Objects

Unit Six UNIT ICON CREDIT: ©Cydney Conger/CORBIS; 62 (1): ©Cydney Conger/CORBIS; 62 (2): ©Dean Conger/CORBIS; 62 (3): ©Bob Krist/CORBIS; 62 (4): ©Vince Streano/CORBIS; 62 (5): ©Elfi Kluck/Index Stock Imagery Inc.; 62 (6): ©Craig Lovell/CORBIS; 62 (7): ©Michael Newman/PhotoEdit; 62 (8): ©RO-MA Stock/Index Stock Imagery Inc.; 62 (9, 10): ©Hemera Photo-Objects; 62 (11): ©Massimo Listri/CORBIS; 62 (12): ©Joseph Sohm; Visions of America/CORBIS; 62 (13): ©Reinhard Eisele/CORBIS; 62 (15): ©Yvette Cardozo/Index Stock Imagery Inc.; 62 (16): ©Philip Coblentz/Brand X Pictures; 62 (17): ©Phil Cantor/SuperStock; 63 (14): ©Pawel Libera/CORBIS; 63 (18): ©Rene Sheret/Stone/Getty; 63 (19): ©Mitch Diamond/Index Stock Imagery Inc.; 63 (20): ©Anselm Sprng/Image Bank/Getty; 63 (21): ©Royalty-Free/CORBIS; 63 (22): ©Joseph Sohm; ChromaSohm Inc./CORBIS; 63 (23): ©Michael S. Yamashita/CORBIS; 67: ©Hemera Photo-Objects

Unit Seven UNIT ICON CREDIT: ©Burke-Triolo Productions/Getty; 82-85 most: ©Hemera Photo-Objects; 82 (5): ©Photodisc Collection/Getty; 82 (11): ©Seide Preis/Getty; 82 (17): ©Royalty-Free/CORBIS; 82 (24): ©Picture Arts/CORBIS; 82 (27): ©Keith Seaman/FoodPix; 82 (33): ©Maximilian Stock, LTD/FoodPix; 83 (7): ©Photodisc Inc./Getty; 83 (28): ©Paul Poplis/FoodPix; 84 (2): ©Judd Pilosof/FoodPix; 84 (9, 18): ©Royalty-Free/CORBIS; 84 (10): ©John Coletti; 84 (20): ©Picture Arts/CORBIS; 84 (21): ©Evan Sklar/Food Pix; 84 (22): ©Cindy Jones/FoodPix; 84 (30): ©Craig Orsini/Index Stock Imagery Inc.; 85 (25): ©Picture Arts/CORBIS

Unit Eight UNIT ICON CREDIT: ©C Squared Studios/Getty; 97 bottom right: ©Hemera Photo-Objects; 112 (1, 10): ©Veer Incorporated; 112 (2): ©Royalty-Free Division/Masterfile; 112 (3): ©Nick Koudis/Getty; 112 (4): ©Barry David Marcus/SuperStock; 112 (6): ©Jules Frazier/Getty; 112 (7): ©D. Boone/CORBIS; 112 (11): ©Stacy Gold/National Geographic/Getty; 113 (5): ©Royalty-Free/CORBIS; 113 (8): ©Veer Incorporated; 113 (9): ©Reuters/CORBIS; 113 (12): ©Francisco Rojo Alvarez/Getty

Unit Nine UNIT ICON CREDIT: ©Wes Thompson/CORBIS

Unit Ten UNIT ICON CREDIT: ©Herrmann/Starke/CORBIS; 140 top center: ©Hemera Photo-Objects; 142 all: ©Hemera Photo-Objects; 144 (1): ©Amy Etra/PhotoEdit; 144 (2, 3, 12, 14, 15): ©Photodisc Collection/Getty; 144 (4, 7, 13): ©John Coletti; 144 (5, 8, 10, 11): ©Hemera Photo-Objects; 144 (6): ©Seide Preis/Photodisc Green/Getty; 144 (9): ©Joe Atlas/Brand X Pictures; 145 top left: ©Stockbyte/Ablestock; 145 (16): ©Michael Newman/PhotoEdit; 145 (17, 20, 23, 26, 28): ©John Coletti; 145 (18): ©COMSTOCK Images; 145 (19, 21, 24, 25, 27): ©Hemera Photo-Objects; 145 (22): ©C Squared Studios/Photodisc Green/Getty; 145 (29, 30, 31): ©Joe Atlas/Brand X Pictures

Unit Eleven UNIT ICON CREDIT: ©PictureNet/CORBIS; 160-163 most: ©Hemera Photo-Objects; 160 (1, 4, 7, 18): ©COMSTOCK Images; 160 (3): ©C Squared Studios/Photodisc Green/Getty; 160 (9): ©Seide Preis/Photodisc Green/Getty; 160 (12): ©Photodisc Green/Getty; 161 (24, 30): ©C Squared Studios/Photodisc Green/Getty; 161 (26): ©Royalty-Free/CORBIS; 161 (32): ©Stockbyte; 162 (3): ©Seide Preis/Photodisc Green/Getty; 162 (4, 5, 28): ©John Coletti; 162 (6): ©Patrick Olear/Photo Edit; 162 (7, 14, 17): ©C Squared Studios/Photodisc Green/Getty; 162 (8): ©Jules Frazier/Getty; 162 (12): ©COMSTOCK Images; 163 (18): ©Royalty-Free/CORBIS; 163 (19, 29): ©John Coletti; 163 (20, 22, 24): ©Seide Preis/Photodisc Green/Getty; 163 (30): ©Widstock/Alamy

Unit Twelve UNIT ICON CREDIT: ©L. Clarke/CORBIS; 174: ©Digital Vision

Unit Thirteen UNIT ICON CREDIT: ©Digital Vision/Getty; 183 (25): ©Hemera Photo-Objects; 184 (1): ©Hemera Photo-Objects; 186 (7): ©Photodisc Collection/Getty; 191 (29): ©Jules Frazier/Getty

Unit Fourteen UNIT ICON CREDIT: ©Don Farrall/Getty; 194 (8, 14): ©Hemera Photo-Objects; 194 (9): ©Dennis MacDonald/PhotoEdit; 194 (7): ©Thinkstock LLC/Index Stock Imagery, Inc.; 194 (13): ©Seide Preis/Photodisc Green/Getty; 195 (18, 20, 21, 22, 27): ©Hemera Photo-Objects; 195 (15): ©Widstock/Alamy; 195 (23, 24, 25, 26): ©Seide Preis/Photodisc Green/Getty; 195 (28, 30): ©COMSTOCK Images; 195 (29): ©TRBfoto/Photodisc Green/Getty

Unit Fifteen UNIT ICON CREDIT: ©Don Farrall/Getty; 203: ©Hemera Photo-Objects; 206-207 most: ©Hemera Photo-Objects; 206 (1, 6, 22): ©Photodisc Collection/Getty; 206 (8, 18, 19): ©C Squared Studios/Photodisc Green/Getty; 207 (3, 13, 15, 16, 17, 26, 28): ©Photodisc Collection/Getty; 207 (2): ©Spencer Grant/PhotoEdit; 207 (27): ©Photodisc Green/Getty

Unit Sixteen UNIT ICON CREDIT: ©Digital Vision/Getty; 212 (1): ©Hemera Photo-Objects; 223 (25): ©Hemera Photo-Objects; 224-226 most: ©Hemera Photo-Objects; 224 (1): ©Royalty-Free/CORBIS; 224 (22): ©John Coletti; 225 (15): ©C Squared Studios/Getty; 225 (16): ©ACE STOCK LTD/Alamy; 225 (19): ©Erin Garvey/Index Stock Imagery, Inc.; 226 (1): ©C Squared Studios/Getty; 226 (3): ©COMSTOCK Images; 226 (7): ©F. Schlusser/Photolink/Getty; 227 most: ©COMSTOCK Images; 227 (9): ©Mediacolors/Alamy; 227 (14, 15, 19, 21, 23): ©Hemera Photo-Objects; 227 (20): ©Judith Collins/Alamy; 227 (24, 25): ©John Coletti

The Heinle Picture Dictionary

Text	0-8384-4400-8	Bilingual Editions	
Workbook—beginning	0-8384-4401-6	Chinese, Traditional	1-4130-0553-5
Workbook—intermediate	1-4130-1467-4	Chinese, Simplified	981-254-812-2
Audio CDs	0-8384-4405-9	Japanese	1-4130-0551-9
Audio Tapes	0-8384-4406-7	Korean	1-4130-0552-7
Lesson Planner with		Portuguese, Brazilian	1-4130-0550-0
Activity Bank CD-ROM	0-8384-4413-X	Spanish	1-4130-0549-7
Interactive CD-ROM	0-8384-4410-5		

Thomson ELT Contact Information

United States

Thomson Heinle
25 Thomson Place
Boston, MA 02210
U.S.A.
Tel: 800-237-0053 or 617-289-7700
Fax: 617-289-7844

Asia

Thomson Learning
(A division of Thomson Corporation K.K.)
5 Shenton Way
#01-01 UIC Building
Singapore 068808
Tel: 65-6410-1200
Fax: 65-6410-1208
Info@thomsonlearning.com.sg

Australia/New Zealand

Nelson Thomson Learning
102 Dodds Street
Southbank, Victoria 3006
Australia
Tel: 61-(0)3-9685-4111
Fax: 61-(0)3-9685-4199
customerservice@nelson.com.au

Brazil

Plonela Thomson Learning Ltda.
Rua Traipú, 114- 3º Andar
Perdizes
CEP 01235-000 São Paulo - SP
Brasil
Tel: 55-11-3665-9900
Fax: 55-11-3665-9901
thomson@thomsonlearning.com.br

Canada

Nelson, a Thomson Company
1120 Birchmount Road
Toronto, Ontario M1K 5G4
Canada
Tel: 416-752-9448
Fax: 416-752-8102
Inquire@nelson.com

Japan

Thomson Learning
(A division of Thomson Corporation K.K.)
Nihonjisy Brooks Bldg 3-F
1-4-1, Kudankita
Chiyoda-ku
Tokyo 102-0073
Japan
Tel: 81-3-3511-4390
Fax: 81-3-3511-4391
elt@tlj.co.jp

Korea

Thomson Learning
(A division of Thomson Corporation Korea Limited)
Suite 301 Richemont Building
114-5 Sung San-Dong Ma Po-ku
Seoul 121-250
Tel: 82-2-322-4926
Fax: 82-2-322-4927
korea@thomsonlearning.com.sg

Latin America

Thomson Learning
Séneca 53
Colonia Polanco
11560 México D.F.
México
Tel: 52-55-1500-6000
Fax: 52-55-5281-2656
elt@thomsonlearning.com.mx

Spain/Portugal

Parainfo/Thomson Learning
Calle Magallanes 25
28015 - Madrid
España
Tel: 34-(0)91-446-3350
Fax: 34-(0)91-445-6218

Taiwan

Thomson Asia Pte Ltd
Taiwan Branch Office
12F, No. 10 Heng Yang Road
Taipei, Taiwan, R.O.C.
Tel: 886-2-2375-1118
Fax: 886-2-2375-1119
taiwan@thomsonlearning.com.sg

UK/Europe/Middle East/Africa

Thomson Learning
High Holborn House
50 / 51 Bedford Row
London WC1R 4LR
United Kingdom
Tel: 44-20-7067-2500
Fax: 44-20-7067-2600

A picture is worth 4,000 words!

THE HEINLE PICTURE DICTIONARY

Unlike other dictionaries, The Heinle Picture Dictionary presents new vocabulary within thematic readings, offers opportunities to practice new words with multi-skill activities, and introduces students to high-frequency English collocations.

- **4,000 words** are taught contextually through color photographs and illustrations, readings, and activities in 16 thematic units.
- **Words in Context** shows how the language is actually used through accessible, contextualized readings.
- **Words in Action** offers activities designed to help students put the words to meaningful use.
- **Word Partnerships** exposes students to high-frequency word patterns and collocations.
- The **Audio Program** allows students to hear each word pronounced and to hear the *Words in Context* as a read-along.
- The **Lesson Planner**, with 342 fully developed lesson plans, provides extensive multilevel support for the busy teacher.
- The **Activity Bank CD-ROM**, included in the Lesson Planner, contains reproducible activity masters that can be customized for individual and classroom use.
- The **Beginning and Intermediate Workbooks** provide extensive vocabulary and listening practice. Each includes its own audio program.
- The **Interactive CD-ROM** offers students additional vocabulary practice through activities, games, and word webs.

